

# GAS TURBINE ENGINE

## Aviation Maintenance Technician Certification Series



- Fundamentals
- Engine Performance
- Inlet
- Compressors
- Combustion Section
- Turbine Section
- Exhaust
- Bearings and Seals
- Lubricants and Fuels
- Lubrication Systems
- Fuel Systems
- Air Systems
- Starting and Ignition Systems
- Engine Indication Systems
- Power Augmentation Systems
- Turboprop Engines
- Turboshaft Engines
- Auxiliary Power Units (APUs)
- Powerplant Installation
- Fire Protection Systems
- Engine Monitoring and Ground Operation
- Engine Storage and Preservation



# EASA Part-66 Aviation Maintenance Technician Certification Series

## NO COST REVISION/UPDATE SUBSCRIPTION PROGRAM



Complete EASA Part-66 Aviation Maintenance Technician Certification Series

### NO COST REVISION/UPDATE PROGRAM

Aircraft Technical Book Company is offering a revision/update program to our customers who purchase an EASA Module from the EASA Aviation Maintenance Technician Certification Series. The update is good for two (2) years from time of registration of any EASA Module or EASA bundled kits. If a revision occurs within two (2) years from date of registration, we will send you the revised pages FREE of cost to the registered email. Go to the link provided at the bottom of this page and fill out the form to be included in the EASA Revision/Update Subscription Program. In an effort to provide quality customer service please let us know if your email you register with changes so we can update our records.

If you have any questions about this process please send an email to: [techsupport@actechbooks.com](mailto:techsupport@actechbooks.com)

### HERE'S HOW IT WORKS

1. All EASA Module Series textbooks contain an EASA subscription page explaining the subscription update process and provide a web site link to register for the EASA Revision/Update Subscription Program.
2. Go to the link provided below and fill out the web based form with your *first and last name, current email address, and school* if applicable.
3. From the time of purchase, if a revision occurs to the Module you have registered for, a revised PDF file containing the pages with edits will be sent to the registered email provided.
4. Please note that we try to keep our records as current as possible. If your email address provided at time of registration changes please let us know as soon as possible so we can update your account.
5. This service is FREE of charge for two (2) years from date of registration.

### LINK TO REGISTER FOR REVISION/UPDATE PROGRAM

<http://www.actechbooks.com/easasub/m15>



**MODULE 15**

**FOR B1 CERTIFICATION**

# **GAS TURBINE ENGINE**

## **Aviation Maintenance Technician Certification Series**



72413 U.S. Hwy 40  
Tabernash, CO 80478-0270 USA

[www.actechbooks.com](http://www.actechbooks.com)

+1 970 726-5111

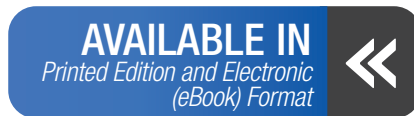

## AVIATION MAINTENANCE TECHNICIAN CERTIFICATION SERIES

Contributor     Richard D. Brauhn II, Indian Hill Community College  
Layout/Design   Michael Amrine

Copyright © 2016 — Aircraft Technical Book Company. All Rights Reserved.

No part of this publication may be reproduced, stored in a retrieval system, transmitted in any form or by any means, electronic, mechanical, photocopying, recording or otherwise, without the prior written permission of the publisher.

To order books or for Customer Service, please call +1 970 726-5111.

[www.actechbooks.com](http://www.actechbooks.com)

Printed in the United States of America



# WELCOME

The publishers of this Aviation Maintenance Technician Certification Series welcome you to the world of aviation maintenance. As you move towards EASA certification, you are required to gain suitable knowledge and experience in your chosen area. Qualification on basic subjects for each aircraft maintenance license category or subcategory is accomplished in accordance with the following matrix. Where applicable, subjects are indicated by an "X" in the column below the license heading.

For other educational tools created to prepare candidates for licensure, contact Aircraft Technical Book Company.

We wish you good luck and success in your studies and in your aviation career!

## EASA LICENSE CATEGORY CHART

Module number and title		A1 Airplane Turbine	B1.1 Airplane Turbine	B1.2 Airplane Piston	B1.3 Helicopter Turbine	B2 Avionics
1	Mathematics	X	X	X	X	X
2	Physics	X	X	X	X	X
3	Electrical Fundamentals	X	X	X	X	X
4	Electronic Fundamentals		X	X	X	X
5	Digital Techniques / Electronic Instrument Systems	X	X	X	X	X
6	Materials and Hardware	X	X	X	X	X
7A	Maintenance Practices	X	X	X	X	X
8	Basic Aerodynamics	X	X	X	X	X
9A	Human Factors	X	X	X	X	X
10	Aviation Legislation	X	X	X	X	X
11A	Turbine Aeroplane Aerodynamics, Structures and Systems	X	X			
11B	Piston Aeroplane Aerodynamics, Structures and Systems			X		
12	Helicopter Aerodynamics, Structures and Systems				X	
13	Aircraft Aerodynamics, Structures and Systems					X
14	Propulsion					X
15	Gas Turbine Engine	X	X		X	
16	Piston Engine			X		
17A	Propeller	X	X	X		

# FORWARD

PART-66 and the Acceptable Means of Compliance (AMC) and Guidance Material (GM) of the European Aviation Safety Agency (EASA) Regulation (EC) No. 1321/2014, Appendix 1 to the Implementing Rules establishes the Basic Knowledge Requirements for those seeking an aircraft maintenance license. The information in this Module of the Aviation Maintenance Technical Certification Series published by the Aircraft Technical Book Company meets or exceeds the breadth and depth of knowledge subject matter referenced in Appendix 1 of the Implementing Rules. However, the order of the material presented is at the discretion of the editor in an effort to convey the required knowledge in the most sequential and comprehensible manner. Knowledge levels required for Category A1, B1, B2, and B3 aircraft maintenance licenses remain unchanged from those listed in Appendix 1 Basic Knowledge Requirements. Tables from Appendix 1 Basic Knowledge Requirements are reproduced at the beginning of each module in the series and again at the beginning of each Sub-Module.

How numbers are written in this book:

This book uses the International Civil Aviation Organization (ICAO) standard of writing numbers. This methods displays large numbers by adding a space between each group of 3 digits. This is opposed to the American method which uses commas and the European method which uses periods. For example, the number one million is expressed as so:

ICAO Standard	1 000 000
European Standard	1.000.000
American Standard	1,000,000

SI Units:

The International System of Units (SI) developed and maintained by the General Conference of Weights and Measures (CGPM) shall be used as the standard system of units of measurement for all aspects of international civil aviation air and ground operations.

Prefixes:

The prefixes and symbols listed in the table below shall be used to form names and symbols of the decimal multiples and submultiples of International System of Units (SI) units.

MULTIPLICATION FACTOR	PREFIX	SYMBOL
1 000 000 000 000 000 000 = 10 <sup>18</sup>	exa	E
1 000 000 000 000 000 = 10 <sup>15</sup>	peta	P
1 000 000 000 000 = 10 <sup>12</sup>	tera	T
1 000 000 000 = 10 <sup>9</sup>	giga	G
1 000 000 = 10 <sup>6</sup>	mega	M
1 000 = 10 <sup>3</sup>	kilo	k
100 = 10 <sup>2</sup>	hecto	h
10 = 10 <sup>1</sup>	deca	da
0.1 = 10 <sup>-1</sup>	deci	d
0.01 = 10 <sup>-2</sup>	centi	c
0.001 = 10 <sup>-3</sup>	milli	m
0.000 001 = 10 <sup>-6</sup>	micro	μ
0.000 000 001 = 10 <sup>-9</sup>	nano	n
0.000 000 000 001 = 10 <sup>-12</sup>	pico	p
0.000 000 000 000 001 = 10 <sup>-15</sup>	femto	f
0.000 000 000 000 000 001 = 10 <sup>-18</sup>	atto	a

International System of Units (SI) Prefixes

The turbine engine powers all modern transport category aircraft. Capable of producing extremely high thrust with notable reliability, the turbofan engine is the most common type of turbine engine found on airline aircraft. Turbo shaft turbine engines are used in helicopter powerplants and auxiliary power units. The turboprop turbine engine is used on smaller commercial passenger-carrying aircraft with propellers. The function, operation, performance, inspection and repair of all types of turbine engines are covered in this module. Basic installations, storage and fire protection of aircraft turbine engines are also discussed.

*Module 15 Syllabus as outlined in PART-66, Appendix 1.*

CERTIFICATION CATEGORY →	LEVELS	
	A1	B1
<b>Sub-Module 01 - Fundamentals</b> Potential energy, kinetic energy, Newton's laws of motion, Brayton cycle; The relationship between force, work, power, energy, velocity, acceleration; Constructional arrangement and operation of turbojet, turbofan, turboshaft, turboprop.	1	2
<b>Sub-Module 02 - Engine Performance</b> Gross thrust, net thrust, choked nozzle thrust, thrust distribution, resultant thrust, thrust horsepower, equivalent shaft horsepower, specific fuel consumption; Engine efficiencies; Bypass ratio and engine pressure ratio; Pressure, temperature and velocity of the gas flow; Engine ratings, static thrust, influence of speed, altitude and hot climate, flat rating, limitations.	-	2
<b>Sub-Module 03 - Inlet</b> Compressor inlet ducts; Effects of various inlet configurations; Ice protection.	2	2
<b>Sub-Module 04 - Compressors</b> Axial and centrifugal types; Constructional features and operating principles and applications; Fan balancing; Operation: Causes and effects of compressor stall and surge; Methods of air flow control: bleed valves, variable inlet guide vanes, variable stator vanes, rotating stator blades; Compressor ratio.	1	2



CERTIFICATION CATEGORY →	LEVELS	
	A1	B1
<b>Sub-Module 05 - Combustion Section</b> Constructional features and principles of operation.	1	2
<b>Sub-Module 06 - Turbine Section</b> Operation and characteristics of different turbine blade types; Blade to disk attachment; Nozzle guide vanes; Causes and effects of turbine blade stress and creep.	2	2
<b>Sub-Module 07 - Exhaust</b> Constructional features and principles of operation; Convergent, divergent and variable area nozzles; Engine noise reduction; Thrust reverser's.	1	2
<b>Sub-Module 08 - Bearings and Seals</b> Constructional features and principles of operation.	-	2
<b>Sub-Module 09 - Lubricants and Fuels</b> Properties and specifications; Fuel additives; Safety precautions.	1	2
<b>Sub-Module 10 - Lubrication Systems</b> System operation / lay-out and components.	1	2
<b>Sub-Module 11 - Fuel Systems</b> Operation of engine control and fuel metering systems including electronic engine control (FADEC); Systems lay-out and components.	1	1
<b>Sub-Module 12 - Air Systems</b> Operation of engine air distribution and anti-ice control systems, including internal cooling, sealing and external air services.	1	1
<b>Sub-Module 13 - Starting and Ignition Systems</b> Operation of engine start systems and components; Ignition systems and components; Maintenance safety requirements.	1	1

## LEVELS

### CERTIFICATION CATEGORY →

**A1**

**B1**

#### Sub-Module 14 - Engine Indication Systems

Exhaust Gas Temperature/Interstage Turbine Temperature;  
 Engine Thrust Indication: Engine Pressure Ratio, engine turbine discharge pressure or jet pipe pressure systems;  
 Oil pressure and temperature;  
 Fuel pressure and flow;  
 Engine speed;  
 Vibration measurement and indication;  
 Torque;  
 Power.

1

2

#### Sub-Module 15 - Power Augmentation Systems

Operation and applications;  
 Water injection, water methanol;  
 Afterburner systems.

-

1

#### Sub-Module 16 - Turbo-prop Engines

Gas coupled/free turbine and gear coupled turbines;  
 Reduction gears;  
 Integrated engine and propeller controls;  
 Overspeed safety devices.

1

2

#### Sub-Module 17 - Turbo-shaft Engines

Arrangements, drive systems, reduction gearing, couplings, control systems.

1

2

#### Sub-Module 18 - Auxiliary Power Units (APUs)

Purpose, operation, protective systems.

1

2

#### Sub-Module 19 - Powerplant Installation

Configuration of firewalls, cowlings, acoustic panels, engine mounts, anti-vibration mounts, hoses, pipes, feeders, connectors, wiring looms, control cables and rods, lifting points and drains.

1

2

#### Sub-Module 20 - Fire Protection Systems

Operation of detection and extinguishing systems.

1

2

#### Sub-Module 21 - Engine Monitoring and Ground Operation

Procedures for starting and ground run-up;  
 Interpretation of engine power output and parameters;  
 Trend (including oil analysis, vibration and boroscope) monitoring;  
 Inspection of engine and components to criteria, tolerances and data specified by engine manufacturer;  
 Compressor washing/cleaning;  
 Foreign Object Damage.

1

3

**LEVELS**

**CERTIFICATION CATEGORY →**

**A1**

**B1**

---

**Sub-Module 22 - Engine Storage and Preservation**

Preservation and de preservation for the engine and accessories / systems.

-

2

**GAS TURBINE ENGINE**

Welcome ..... iii  
 Forward..... iv  
 Preface..... v  
 Revision Log..... xiv

**SUB-MODULE 01**

**FUNDAMENTALS**

Knowledge Requirements ..... 1.1  
 Turbine Engine Fundamentals..... 1.2  
 Energy..... 1.2  
     Potential Energy ..... 1.2  
     Kinetic Energy..... 1.2  
 Newton's Laws of Motion ..... 1.3  
     First Law ..... 1.3  
     Second Law ..... 1.3  
     Third Law..... 1.4  
 Bernoulli's principle ..... 1.4  
 Boyle's & Charles' Law..... 1.5  
 Force, Work, Power and Torque ..... 1.5  
     Force..... 1.5  
     Work ..... 1.6  
     Power ..... 1.6  
     Torque ..... 1.7  
 Motion ..... 1.7  
     Speed and Velocity..... 1.8  
     Acceleration ..... 1.8  
 General Requirements ..... 1.9  
     Power and Weight ..... 1.10  
     Fuel Economy ..... 1.10  
     Durability and Reliability ..... 1.11  
     Operating Flexibility ..... 1.11  
     Compactness ..... 1.11  
 Types and Construction ..... 1.11  
     Turbine Engine Types ..... 1.12  
     Bypass Ratio..... 1.12  
 Questions ..... 1.15  
 Answers ..... 1.16

**SUB-MODULE 02**

**ENGINE PERFORMANCE**

Knowledge Requirements ..... 2.1  
 Engine Performance ..... 2.2  
     Turbine Engine Operating Principles ..... 2.2  
     Thrust..... 2.2  
     The Brayton Cycle ..... 2.3  
 Gas Turbine Engine Performance ..... 2.5

Ram Recovery ..... 2.6  
 Engine Ratings ..... 2.7  
 Engine Pressure Ratio ..... 2.7  
 Questions ..... 2.9  
 Answers ..... 2.10

**SUB-MODULE 03**

**INLET**

Knowledge Requirements ..... 3.1  
 Inlets and Accessory ..... 3.2  
     Air Entrance ..... 3.2  
 Turbine Engine Inlet Systems ..... 3.2  
     Divided-Entrance Duct..... 3.3  
     Variable-Geometry Duct..... 3.4  
     Compressor Inlet Screens ..... 3.4  
     Bellmouth Compressor Inlets ..... 3.5  
 Turboprop and Turboshaft Compressor Inlets ..... 3.6  
 Turbofan Engine Inlet Sections ..... 3.6  
 Questions ..... 3.9  
 Answers ..... 3.10

**SUB-MODULE 04**

**COMPRESSORS**

Knowledge Requirements ..... 4.1  
 Compressor Section ..... 4.2  
     Compressor Types and Applications..... 4.2  
     Centrifugal-Flow Compressors..... 4.2  
     Axial-Flow Compressor ..... 4.4  
 Diffuser..... 4.6  
 Fan Balance..... 4.6  
 Compressor Stall and Surge ..... 4.7  
 Questions ..... 4.9  
 Answers ..... 4.10

**SUB-MODULE 05**

**COMBUSTION SECTION**

Knowledge Requirements ..... 5.1  
 Combustion Section ..... 5.2  
 Questions ..... 5.7  
 Answers ..... 5.8

**SUB-MODULE 06**

**TURBINE SECTION**

Knowledge Requirements ..... 6.1  
 Turbine Area Inspection..... 6.2  
     Turbine Section ..... 6.2  
 Questions ..... 6.9

# CONTENTS

Answers .....	6.10
---------------	------

## SUB-MODULE 07

### EXHAUST

Knowledge Requirements .....	7.1
Exhaust Section .....	7.2
Exhaust Nozzles .....	7.4
Convergent Exhaust Nozzle .....	7.5
Convergent-Divergent Exhaust Nozzle .....	7.5
Thrust Reverser's .....	7.6
Thrust Vectoring .....	7.8
Engine Noise Suppression .....	7.8
Turbine Engine Emissions .....	7.10
Questions .....	7.11
Answers .....	7.12

## SUB-MODULE 08

### BEARINGS AND SEALS

Knowledge Requirements .....	8.1
Bearings and Seals .....	8.2
Questions .....	8.5
Answers .....	8.6

## SUB-MODULE 09

### LUBRICANTS AND FUELS

Knowledge Requirements .....	9.1
Lubricants and Fuels .....	9.2
Requirements for Turbine Engine Lubricants .....	9.2
Turbine Oil Health and Safety Precautions .....	9.2
Turbine Engine Fuels .....	9.3
Turbine Fuel Volatility.....	9.4
Turbine Engine Fuel Types .....	9.4
Fuel Identification .....	9.4
Purity .....	9.4
Microbes .....	9.5
Questions .....	9.7
Answers .....	9.8

## SUB-MODULE 10

### LUBRICATION SYSTEMS

Knowledge Requirements .....	10.1
Turbine Engine Lubrication Systems.....	10.2
Turbine Lubrication System Components .....	10.2
Oil Tank.....	10.2
Oil Pump .....	10.3
Oil Pressure Regulating Valve.....	10.5
Oil Pressure Relief Valve.....	10.6

Oil Jets .....	10.6
Lubrication System Instrumentation .....	10.7
Lubrication System Breather Systems (Vents) .....	10.7
Lubrication System Check Valve.....	10.8
Lubrication System Thermostatic Bypass Valves ....	10.8
Air Oil Coolers .....	10.8
Fuel Oil Coolers .....	10.9
Deoiler .....	10.9
Magnetic Chip Detectors .....	10.9
Typical Dry-Sump Pressure Regulated Turbine Lubrication System.....	10.10
Pressure System .....	10.10
Scavenge System .....	10.10
Breather Pressurizing System .....	10.11
Typical Dry-Sump Variable Pressure Lubrication System.....	10.11
Pressure Subsystem .....	10.11
Scavenger Subsystem .....	10.12
Breather Subsystems .....	10.12
Turbine Engine Wet-Sump Lubrication System .....	10.13
Accessory Section .....	10.13
Questions .....	10.15
Answers .....	10.16

## SUB-MODULE 11

### FUEL SYSTEMS

Knowledge Requirements .....	11.1
Turbine Engine Fuel Systems.....	11.2
General Requirements.....	11.2
Turbine Fuel Controls .....	11.2
Hydromechanical Fuel Controls .....	11.3
Hydromechanical/Electronic Fuel Control .....	11.3
FADEC Fuel Control Systems .....	11.5
FADEC for an Auxiliary .....	11.5
Power Unit .....	11.5
FADEC Fuel Control Propulsion Engine .....	11.7
Fuel System Operation .....	11.9
Engine Fuel System Components .....	11.10
Main Fuel Pumps (Engine Driven) .....	11.10
Fuel Heater .....	11.11
Fuel Filters.....	11.11
Fuel Spray Nozzles and Fuel Manifolds .....	11.12
Simplex Fuel Nozzle.....	11.13
Duplex Fuel Nozzle .....	11.13
Airblast Nozzles .....	11.13
Flow Divider .....	11.14
Fuel Pressurizing and Dump Valves .....	11.14

Combustion Drain Valves .....	11.15
Fuel Quantity Indicating Units .....	11.15
Questions .....	11.17
Answers .....	11.18

**SUB-MODULE 12**

**AIR SYSTEMS**

Knowledge Requirements .....	12.1
Air Systems.....	12.2
Turbine Engine Cooling .....	12.2
Accessory Zone Cooling.....	12.2
Anti-Ice Control Systems .....	12.3
Questions .....	12.5
Answers .....	12.6

**SUB-MODULE 13**

**STARTING AND IGNITION SYSTEMS**

Knowledge Requirements .....	13.1
Starting Systems.....	13.2
Gas Turbine Engine Starters.....	13.2
Cartridge Pneumatic Starters .....	13.2
Electric Starting Systems and Starter Generator	
Starting Systems .....	13.3
Troubleshooting a Starter Generator Starting	
System .....	13.5
Air Turbine Starters .....	13.5
Air Turbine Troubleshooting Guide .....	13.9
Turbine Engine Ignition Systems .....	13.10
Ignition System Maintenance Safety .....	13.12
Capacitor Discharge Exciter Unit .....	13.12
Igniter Plugs.....	13.13
Turbine Ignition System Inspection and	
Maintenance .....	13.14
Inspection.....	13.14
Check System Operation.....	13.14
Repair.....	13.15
Removal, Maintenance and Installation of Ignition	
System .....	13.15
Components.....	13.15
Ignition System Leads .....	13.15
Igniter Plugs.....	13.15
Questions .....	13.17
Answers .....	13.18

**SUB-MODULE 14**

**ENGINE INDICATION SYSTEMS**

Knowledge Requirements .....	14.1
Engine Indicating Systems.....	14.2
Exhaust Gas Temperature Indicator (EGT).....	14.2
Engine Pressure Ratio (EPR)Indicator.....	14.4
Torquemeter (Turboprop Engines) .....	14.4
Tachometer .....	14.5
Fuel-Flow Indicator.....	14.6
Engine Oil Pressure Indicator.....	14.6
Engine Oil Temperature Indicator .....	14.6
Vibration Monitoring .....	14.6
Questions .....	14.9
Answers .....	14.10

**SUB-MODULE 15**

**POWER AUGMENTATION SYSTEMS**

Knowledge Requirements .....	15.1
Power Augmentation Systems .....	15.2
After Burning/Thrust Augmentation .....	15.2
Water Injection System .....	15.3
Questions .....	15.5
Answers .....	15.6

**SUB-MODULE 16**

**TURBO-PROP ENGINES**

Knowledge Requirements .....	16.1
Turboprop Engines.....	16.2
Gear Coupled / Fixed Turbine and Free Turbine ...	16.2
Turboprop Controls .....	16.2
Reduction Gear Assembly.....	16.4
Turbo-Propeller Assembly.....	16.4
Over speed Safety Devices .....	16.4
Questions .....	16.7
Answers .....	16.8

**SUB-MODULE 17**

**TURBO-SHAFT ENGINES**

Knowledge Requirements .....	17.1
Turboshaft Engines .....	17.2
Reduction Gearing .....	17.2
Couplings and Drive Systems .....	17.2
Control Systems.....	17.2
Questions .....	17.5
Answers .....	17.6

# CONTENTS

## SUB-MODULE 18

### AUXILIARY POWER UNITS (APUS)

Knowledge Requirements .....	18.1
Auxiliary Power Units (APUs).....	18.2
Construction .....	18.2
Installation .....	18.4
Engine Systems .....	18.4
APU Control .....	18.6
Crew Control and Monitoring .....	18.7
Flight Certified APUs.....	18.7
Inspection and Servicing.....	18.8
Questions .....	18.9
Answers .....	18.10

## SUB-MODULE 19

### POWERPLANT INSTALLATION

Knowledge Requirements .....	19.1
Powerplant Installations.....	19.2
Firewalls.....	19.2
Cowling .....	19.3
Acoustic Panels .....	19.3
Mounts for Turbofan Engines.....	19.3
Turbine Vibration Isolation Engine Mounts .....	19.3
Control Cables and Rods.....	19.4
Hoses and Pipes.....	19.4
Fuel Lines .....	19.4
Hydraulic Lines .....	19.4
O-Ring Seals .....	19.11
Feeders, Connectors and Wiring Looms .....	19.12
Drains.....	19.14
Lifting Points.....	19.14
Questions .....	19.15
Answers .....	19.16

## SUB-MODULE 20

### FIRE PROTECTION SYSTEMS

Knowledge Requirements .....	20.1
Fire Protection Systems .....	20.2
Components.....	20.2
Engine Fire Detection Systems .....	20.3
Thermal Switch System .....	20.3
Thermocouple Systems .....	20.3
Optical Fire Detection Systems .....	20.4
Infrared Optical Fire Protection .....	20.4
Principle of Operation .....	20.4
Pneumatic Thermal Fire Detection.....	20.4
Continuous-Loop Detector Systems.....	20.4

Fenwal Continuous-Loop System .....	20.5
Kidde Continuous-Loop System .....	20.6
Sensing Element .....	20.6
Combination Fire and Overheat Warning .....	20.6
System Test .....	20.7
Dual-Loop Systems .....	20.7
Automatic Self-Interrogation .....	20.7
Support Tube-Mounted Sensing Elements.....	20.7
Fire Detection Control Unit (Fire Detection Card) ....	20.8
Fire Zones.....	20.8
Engine Fire Extinguishing System .....	20.9
Fire Extinguishing Agents .....	20.9
Turbine Engine Ground Fire Protection .....	20.9
Containers .....	20.10
Pressure Indication .....	20.10
Two-Way Check Valve .....	20.11
Discharge Indicators .....	20.11
Thermal Discharge Indicator (Red Disk) .....	20.11
Yellow Disk Discharge Indicator .....	20.11
Fire Switch.....	20.11
Warning Systems.....	20.12
Boeing 777 Aircraft Fire Detection and Extinguishing System .....	20.12
Overheat Detection .....	20.12
Fire Detection .....	20.12
Nacelle Temperature Recording .....	20.12
Continuous Fault Monitoring .....	20.12
Single/Dual Loop Operation .....	20.13
System Test .....	20.13
Fire Extinguisher Containers .....	20.13
Squib .....	20.14
Engine Fire Switches.....	20.15
Engine Fire Operation .....	20.16
APU Fire Detection and Extinguishing System ....	20.17
APU Fire Warning.....	20.17
Fire Bottle Discharge .....	20.17
Questions .....	20.19
Answers .....	20.20

## SUB-MODULE 21

### ENGINE MONITORING AND GROUND OPERATION

Knowledge Requirements .....	21.1
Engine Monitoring and Ground Operation .....	21.2
Turbine Engine Operation .....	21.2
Ground Operation Engine Fire .....	21.2
Engine Checks.....	21.2

Checking Takeoff Thrust..... 21.2  
 Ambient Conditions ..... 21.3  
 Engine Shutdown ..... 21.4  
 Turboprop Operation ..... 21.4  
 Troubleshooting Turbine Engines ..... 21.4  
 Troubleshooting Procedures for Turboprop Engines 21.6  
 Spectrometric Oil Analysis Program ..... 21.6  
 Typical Wear Metals and Additives ..... 21.6  
 Vibration ..... 21.6  
 Borescope ..... 21.8  
 Turbine Engine Maintenance ..... 21.8  
 Compressor Section..... 21.8  
 Inspection and Cleaning..... 21.9  
 Causes of Blade Damage ..... 21.10  
 Blending and Replacement..... 21.11  
 Combustion Section Inspection ..... 21.12  
 Marking Materials for Combustion Section Parts 21.13  
 Inspection and Repair of Combustion Chambers 21.14  
 Fuel Nozzle and Support Assemblies..... 21.14  
 Turbine Section ..... 21.14  
 Turbine Disk Inspection ..... 21.14  
 Turbine Blade Inspection ..... 21.14  
 Turbine Blade Replacement Procedure ..... 21.16  
 Turbine Nozzle Inlet Guide Vane Inspection .... 21.17  
 Clearances ..... 21.17  
 Exhaust Section ..... 21.17  
 Turbine Engine Accessories ..... 21.19  
 Compressor Washing and Cleaning ..... 21.19  
 Foreign Object Damage (FOD)..... 21.20  
 Questions ..... 21.21  
 Answers ..... 21.22

**SUB-MODULE 22**

**ENGINE STORAGE AND PRESERVATION**

Knowledge Requirements ..... 22.1  
 Engine Storage and Preservation ..... 22.2  
 Corrosion-Preventive Materials ..... 22.2  
 Corrosion-Preventive Compounds ..... 22.2  
 Dehydrating Agents ..... 22.3  
 Engine Shipping Containers ..... 22.3  
 Inspection of Stored Engines ..... 22.4  
 Preservation and Depreservation of Gas Turbine  
 Engines ..... 22.4  
 Preservation and Depreservation of Engine  
 Accessories ..... 22.4  
 Questions ..... 22.5  
 Answers ..... 22.6  
 Acronym Index..... A.1  
 Index ..... I.1



## REVISION LOG

VERSION	ISSUE DATE	DESCRIPTION OF CHANGE	MODIFICATION DATE
001	2016 01	Module Creation and Release	
002	2016 08	Module Revisions and Release	2016 07

### Version 002 Revisions - 2016 08:

1. Relocation of Accessory Case content to lubrication chapter.
2. Added content to Turboshaft engines chapter.
3. Replaced Figure 4-4.
4. Updated format.
5. Corrected various typos.



PART-66 SYLLABUS **LEVELS**  
 CERTIFICATION CATEGORY → **A1** **B1**

**Sub-Module 01**  
**FUNDAMENTALS**

Knowledge Requirements

*15.1 - Fundamentals*

- Potential energy, kinetic energy, Newton's laws of motion, Brayton cycle;
- The relationship between force, work, power, energy, velocity, acceleration;
- Constructional arrangement and operation of turbojet, turbofan, turboshaft, turboprop.

	A1	B1
1		
2		

**Level 1**

A familiarization with the principal elements of the subject.

*Objectives:*

- (a) The applicant should be familiar with the basic elements of the subject.
- (b) The applicant should be able to give a simple description of the whole subject, using common words and examples.
- (c) The applicant should be able to use typical terms.

**Level 2**

A general knowledge of the theoretical and practical aspects of the subject and an ability to apply that knowledge.

*Objectives:*

- (a) The applicant should be able to understand the theoretical fundamentals of the subject.
- (b) The applicant should be able to give a general description of the subject using, as appropriate, typical examples.
- (c) The applicant should be able to use mathematical formula in conjunction with physical laws describing the subject.
- (d) The applicant should be able to read and understand sketches, drawings and schematics describing the subject.
- (e) The applicant should be able to apply his knowledge in a practical manner using detailed procedures.

---

# TURBINE ENGINE FUNDAMENTALS

A discussion of turbine engines begins with some of the basic physics behind turbine engine operation.

---

## ENERGY

Energy is typically defined as something that gives us the capacity to perform work. As individuals, saying that we feel full of energy is probably indicating that we can perform a lot of work. Energy can be classified as one of two types: either potential or kinetic.

### POTENTIAL ENERGY

Potential energy is defined as being energy at rest, or energy that is stored. Potential energy may be classified into three groups: (1) that due to position, (2) that due to distortion of an elastic body, and (3) that which produces work through chemical action.

Water in an elevated reservoir, and an airplane raised off the ground sitting on jacks are examples of the first group; a stretched bungee cord on a Piper Tri-Pacer or compressed spring are examples of the second group; and energy in aviation gasoline, food, and storage batteries are examples of the third group. To calculate the potential energy of an object due to its position, as in height, the following formula is used:

A calculation based on this formula will produce an answer that has units of foot-pounds (ft-lbs) or inch pounds (in-lbs), which are the same units that apply to work. Work, which is covered later in this chapter, is described as a force being applied over a measured distance, with the force being pounds and the distance being feet or inches. It can be seen that potential energy and work have a lot in common.

Example: A Boeing 747 weighing 450 000 pounds needs to be raised 4 feet in the air so maintenance can be done on the landing gear. How much potential energy does the airplane possess because of this raised position?

$$\begin{aligned} \text{Potential Energy} &= \text{Weight} \times \text{Height} \\ PE &= 450\,000\text{ lb} \times 4\text{ ft} \\ PE &= 1\,800\,000\text{ ft-lbs} \end{aligned}$$

As mentioned previously, aviation gasoline possesses potential energy because of its chemical nature. Gasoline has the potential to release heat energy, based on its British thermal unit (BTU) content. One pound of aviation gas contains 18 900 BTU of heat energy, and each BTU is capable of 778 ft-lbs of work. So if we multiply 778 by 18 900, we find that one pound of aviation gas is capable of 14 704 200 ft-lbs of work.

Imagine the potential energy in the completely serviced fuel tanks of an airplane.

### KINETIC ENERGY

Kinetic energy is defined as being energy in motion. An airplane rolling down the runway or a rotating flywheel on an engine are both examples of kinetic energy. Kinetic energy has the same units as potential energy, namely foot-pounds or inch-pounds. To calculate the kinetic energy for something in motion, the following formula is used:

$$\text{Kinetic Energy} = \frac{1}{2} \text{Mass} \times \text{Velocity}^2$$

To use the formula, we will show the mass as weight ÷ gravity and the velocity of the object will be in feet per second. This is necessary to end up with units in foot-pounds.

Example: A Boeing 777 weighing 600 000 lbs is moving down the runway on its takeoff roll with a velocity of 200 fps. How many foot-pounds of kinetic energy does the airplane possess? (*Figure 1-1*)

$$\begin{aligned} \text{Kinetic Energy} &= \frac{1}{2} \text{Mass} \times \text{Velocity}^2 \\ \text{Kinetic Energy} &= \frac{1}{2} \times (600\,000 \div 32.2) \times 200^2 \\ KE &= 372\,670\,807\text{ ft-lb} \end{aligned}$$



Figure 1-1. Kinetic energy (Boeing 777 taking off).

## NEWTON'S LAWS OF MOTION

The physics laws originated by Sir Isaac Newton are particularly applicable to the operation of turbine engines.

### FIRST LAW

*Objects at rest tend to remain at rest and objects in motion tend to remain in motion at the same speed and in the same direction, unless acted on by an external force.*

When a magician snatches a tablecloth from a table and leaves a full setting of dishes undisturbed, he is not displaying a mystic art; he is demonstrating the principle of inertia. Inertia is responsible for the discomfort felt when an airplane is brought to a sudden halt in the parking area and the passengers are thrown forward in their seats. Inertia is a property of matter. This property of matter is described by Newton's first law of motion.

### SECOND LAW

*When a force acts upon a body, the momentum of that body is changed. The rate of change of momentum is proportional to the applied force.*

Bodies in motion have the property called momentum. A body that has great momentum has a strong tendency to remain in motion and is therefore hard to stop. For example, a train moving at even low velocity is difficult to stop because of its large mass. Newton's second law applies to this property.

Based on Newton's second law, the formula for calculating thrust is derived, which states that force equals mass times acceleration:

$$(F = MA)$$

Mass equals weight divided by gravity, and acceleration equals velocity final minus velocity initial divided by time. Putting all these concepts together, the formula for thrust is:

$$\text{Force} = \frac{\text{Weight (Velocity Final - Velocity Initial)}}{\text{Gravity (Time)}}$$

$$F = \frac{W (V_f - V_i)}{Gt}$$

Example: A turbojet engine is moving 150 lbs of air per second through the engine. The air enters going 100 fps and leaves going 1 200 fps. How much thrust, in pounds, is the engine creating?

$$F = \frac{W (V_f - V_i)}{Gt}$$

$$F = \frac{150 (1\,200 - 100)}{32.2 (1)}$$

$$F = 5\,124 \text{ lb of thrust}$$

## THIRD LAW

*For every action there is an equal and opposite reaction.*

Newton's third law of motion is often called the law of action and reaction. This means that if a force is applied to an object, the object will supply a resistive force exactly equal to and in the opposite direction of the force applied. It is easy to see how this might apply to objects at rest. For example, as a man stands on the floor, the floor exerts a force against his feet exactly equal to his weight. But this law is also applicable when a force is applied to an object in motion.

Forces always occur in pairs. The "acting force" means the force one body exerts on a second body, and reacting force means the force the second body exerts on the first.

When an aircraft propeller pushes a stream of air backward with a force of 500 lbs, the air pushes the blades forward with a force of 500 lbs. This forward force causes the aircraft to move forward. A turbofan engine exerts a force on the air entering the inlet duct, causing it to accelerate out the fan duct and the tailpipe. The air accelerating to the rear is the action, and the force inside the engine that makes it happen is the reaction, also called thrust.

## BERNOULLI'S PRINCIPLE

Bernoulli's principle explains the action of a liquid flowing through the varying cross-sectional areas of tubes. In **Figure 1-2** a tube is shown in which the cross-sectional area gradually decreases to a minimum diameter in its center section. A tube constructed in this manner is called a "venturi". Where the cross-sectional area is decreasing, the passageway is referred to as a *converging duct*. As the passageway starts to spread out, it is referred to as a *diverging duct*.

As a fluid flows through the venturi tube, at A, B, and C are positioned to register the velocity and the static pressure of the liquid.

The venturi in **Figure 1-2** is used to illustrate Bernoulli's principle, which states:

*The static pressure of a fluid (liquid or gas) decreases at points where the velocity of the fluid increases, provided no energy is added to nor taken away from the fluid.*

The velocity of the air is kinetic energy and the static pressure of the air is potential energy. In the wide section of the venturi (points A and C of **Figure 1-2**), the liquid moves at low velocity, producing a high static pressure, as indicated by the pressure gauge. As the tube narrows in the center, it must contain the same volume of fluid as the two end areas. In this narrow section, the liquid moves at a higher velocity, producing a lower pressure than that at points A and C, as indicated by the velocity gauge reading high and the pressure gauge reading low.

Bernoulli's principle is important in understanding how some of the systems used in aviation work, including how the wing of an airplane generates lift or why the inlet duct of a turbine engine on a subsonic airplane is diverging in shape.

Key to Bernoulli's principle is that the total pressure of the airflow remains the same while static pressure varies due to negotiation of the curvature of a venturi or wing. As the static pressure of the fluid decreases to move over the curved surface, dynamic pressure increases, expressed as an equation:

$$\text{Total Pressure} = \text{Static Pressure} + \text{Dynamic Pressure}$$

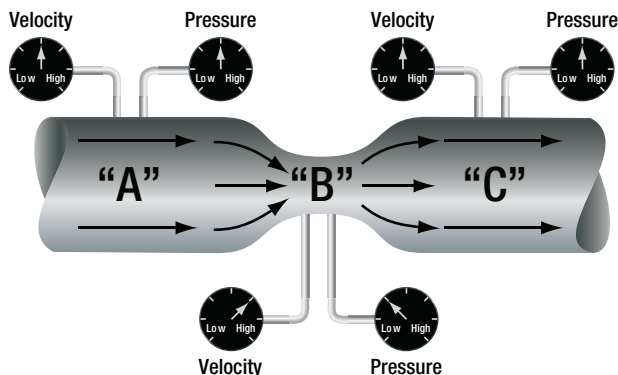

Figure 1-2. Bernoulli's principle and a venturi.

## BOYLE'S & CHARLES' LAW

Boyle's Law states that when the temperature of a gas is kept constant and the pressure increased, its volume is decreased proportionately. In reverse; when a gas is at a constant temperature and pressure decreases, volume increases. (*Figure 1-3*)

By itself Boyle's Law is of little use because in practice air is not compressed at a constant temperature. Although if we use Boyle's Law in combination with Charles' Law, it becomes more useful. Charles' Law states that if air is heated at a constant pressure, the change in volume will vary with the change in temperature. Therefore, the volume of a mass of gas at

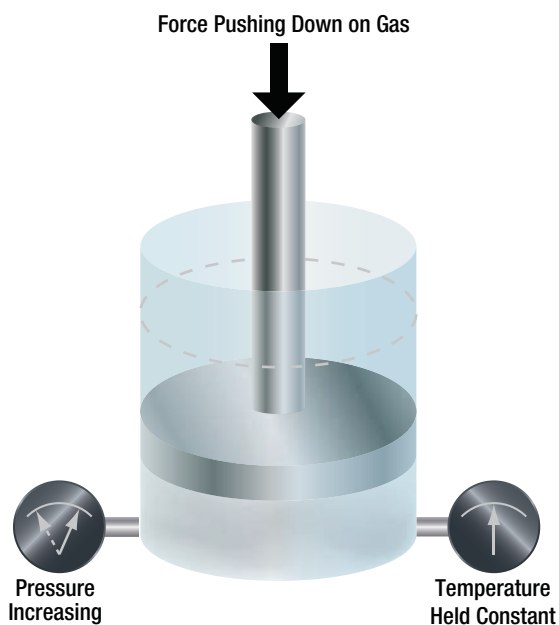

Figure 1-3. Boyle's law example.

constant pressure is proportional to the temperature of the gas (air). So, the product of the pressure and volume of the air through each stage within a turbine engine is proportional to the temperature of the air at the stage.

During compression, as work is done to increase pressure and decrease volume, there is a corresponding rise in temperature. During combustion, the addition of fuel to burn with the air increases the pressure and there is a corresponding increase in volume. During exhaust, there is a decrease in the pressure and temperature of the gas with an additional increase in volume. (*Figure 1-4*)

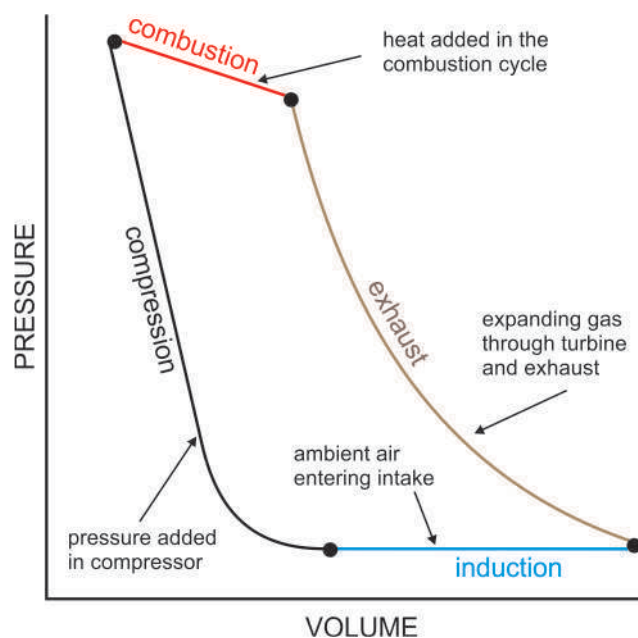

Figure 1-4. Pressure/volume relationship.

## FORCE, WORK, POWER AND TORQUE

### FORCE

Before the concept of work, power, or torque can be discussed, we must understand what force means. According to the dictionary, force is the intensity of an impetus, or the intensity of an input. For example, if we apply a force to an object, the tendency will be for the object to move. Another way to look at it is that for work, power, or torque to exist, there has to be a force that initiates the process.

The unit for force in the English system of measurement is pounds, and in the metric system it is newtons. One pound of force is equal to 4.448 newtons. When we calculate the thrust of a turbine engine, we use the formula "Force = Mass  $\times$  Acceleration," and the thrust of the engine is expressed in pounds. The GE90-115 turbofan engine (powerplant for the Boeing 777-300), for example, has 115 000 pounds of thrust.

## WORK

The study of machines, both simple and complex, is in one sense a study of the energy of mechanical work. This is true because all machines transfer input energy, or the work done on the machine, to output energy, or the work done by the machine.

Work, in the mechanical sense of the term, is done when a resistance is overcome by a force acting through a measurable distance. Two factors are involved: (1) force and (2) movement through a distance. As an example, suppose a small aircraft is stuck in the snow. Two men push against it for a period of time, but the aircraft does not move. According to the technical definition, no work was done in pushing against the aircraft. By definition, work is accomplished only when an object is displaced some distance against a resistive force. To calculate work, the following formula is used:

$$\text{Work} = \text{Force } (F) \times \text{distance } (d)$$

In the English system, the force will be identified in pounds and the distance either in feet or inches, so the units will be foot-pounds or inch-pounds. Notice these are the same units that were used for potential and kinetic energy. In the metric system, the force is identified in newtons (N) and the distance in meters, with the resultant units being joules. One pound of force is equal to 4.448 N and one meter is equal to 3.28 feet. One joule is equal to 1.36 ft-lb.

Example: How much work is accomplished by jacking a 150 000-lb Airbus A-320 airplane a vertical height of 3 ft? (*Figure 1-5*)

$$\begin{aligned}\text{Work} &= \text{Force} \times \text{distance} \\ &= 5\,000 \text{ lbs} \times 4 \text{ ft} \\ &= 600\,000 \text{ ft-lbs}\end{aligned}$$

Example: How much work is accomplished when a tow tractor is hooked up to a tow bar and a Boeing 737-800 airplane weighing 130 000 lbs is pushed 80 ft into the hangar? The force on the tow bar is 5 000 lbs.

$$\begin{aligned}\text{Work} &= \text{Force} \times \text{distance} \\ &= 5\,000 \times 80 \text{ ft} \\ &= 400\,000 \text{ ft-lbs}\end{aligned}$$



Figure 1-5. Airbus A-320 being jacked.

In this last example, notice the force does not equal the weight of the airplane. This is because the airplane is being moved horizontally and not lifted vertically. In virtually all cases, it takes less work to move something horizontally than it does to lift it vertically. Most people can push their car a short distance if it runs out of gas, but they cannot get under it and lift it off the ground.

## POWER

The concept of power involves the previously discussed topic of work, which was a force being applied over a measured distance, but adds one more consideration - time. In other words, how long does it take to accomplish the work. If someone asked the average person if he or she could lift one million pounds 5 feet off the ground, the answer most assuredly would be no. This person would probably assume that he or she is to lift it all at once. What if he or she is given 365 days to lift it, and could lift small amounts of weight at a time?

The work involved would be the same, regardless of how long it took to lift the weight, but the power required is different. If the weight is to be lifted in a shorter period of time, it will take more power. The formula for power is as follows:

$$\text{Power} = \text{Force} \times \text{distance} \div \text{time}$$

The units for power will be foot-pounds per minute, foot-pounds per second, inch-pounds per minute or second, and possibly mile-pounds per hour. The units depend on how distance and time are measured.

Many years ago there was a desire to compare the power of the newly evolving steam engine to that of horses. People wanted to know how many horses the steam

engine was equivalent to. Because of this, the value we currently know as one horsepower (hp) was developed, and it is equal to 550 foot-pounds per second (ft-lb/s). It was found that the average horse could lift a weight of 550 lb, one foot off the ground, in one second. The values we use today, in order to convert power to horsepower, are as follows:

$$\begin{aligned} 1 \text{ hp} &= 550 \text{ ft-lb/s} \\ 1 \text{ hp} &= 33\,000 \text{ ft-lb/min.} \\ 1 \text{ hp} &= 375 \text{ mile pounds per hour (mi-lb/hr)} \\ 1 \text{ hp} &= 746 \text{ watts (electricity conversion)} \end{aligned}$$

To convert power to horsepower, divide the power by the appropriate conversion based on the units being used.

**Example:** What power would be needed, and also horsepower, to raise the GE-90 turbofan engine into position to install it on a Boeing 777-300 airplane? The engine weighs 19 000 lb, and it must be lifted 4 ft in 2 minutes.

$$\begin{aligned} \text{Power} &= \text{Force} \times \text{distance} \div \text{time} \\ &= 19\,000 \text{ lbs} \times 4 \text{ ft} \div 2 \text{ minutes} \\ &= 38\,000 \text{ ft-lbs} / \text{min} \\ \text{Horsepower (Hp)} &= 38\,000 \text{ ft-lbs} / \text{min} \div \\ &\quad 33\,000 \text{ ft-lbs} / \text{min Hp} \\ &= 1.15 \end{aligned}$$

The hoist that will be used to raise this engine into position will need to be powered by an electric motor because the average person will not be able to generate 1.15 hp in their arms for the necessary 2 minutes.

## TORQUE

Torque is a very interesting concept and occurrence, and it is definitely something that needs to be discussed in conjunction with work and power. Whereas work is

described as a force acting through a distance, torque is described as a force acting along a distance. Torque is something that creates twisting and tries to make something rotate. If we push on an object with a force of 10 lbs and it moves 10 inches in a straight line, we have done 100 in-lbs of work. By comparison, if we have a wrench 10 inches long that is on a bolt, and we push down on it with a force of 10 lbs, a torque of 100 lb-in is applied to the bolt. If the bolt was already tight and did not move as we pushed down on the wrench, the torque of 100 lb-in would still exist. The formula for torque is:

$$\text{Torque} = \text{Force} \times \text{distance}$$

Even though the formula looks the same as the one for calculating work, recognize that the distance value in this formula is not the linear distance an object moves, but rather the distance along which the force is applied.

Notice that with torque nothing had to move, because the force is being applied along a distance and not through a distance. Notice also that although the units of work and torque appear to be the same, they are not. The units of work were inch-pounds and the units of torque were pound-inches, and that is what differentiates the two.

Torque is very important when thinking about how engines work. Gas turbine engines create torque in advance of being able to create work or power. The turbine blades at the back of the engine extract energy from the high velocity exhaust gases. The energy extracted becomes a force in pounds pushing on the turbine blades, which happen to be a certain number of inches from the center of the shaft they are trying to make rotate. The number of inches from the turbine blades to the center of the shaft would be like the length of the wrench discussed earlier.

## MOTION

The study of the relationship between the motion of bodies or objects and the forces acting on them is often called the study of "force and motion." In a more specific sense, the relationship between velocity, acceleration, and distance is known as kinematics.

Motion may be defined as a continuing change of position or place, or as the process in which a body

undergoes displacement. When an object is at different points in space at different times, that object is said to be in motion, and if the distance the object moves remains the same for a given period of time, the motion may be described as uniform. Thus, an object in uniform motion always has a constant speed.



## SPEED AND VELOCITY

In everyday conversation, speed and velocity are often used as if they mean the same thing. In physics they have definite and distinct meanings. Speed refers to how fast an object is moving, or how far the object will travel in a specific time. The speed of an object tells nothing about the direction an object is moving. For example, if the information is supplied that an airplane leaves New York City and travels 8 hours at a speed of 150 mph, this information tells nothing about the direction in which the airplane is moving. At the end of 8 hours, it might be in Kansas City, or if it traveled in a circular route, it could be back in New York City.

Velocity is that quantity in physics which denotes both the speed of an object and the direction in which the object moves. Velocity can be defined as the rate of motion in a particular direction. Velocity is also described as being a vector quantity, a vector being a line of specific length, having an arrow on one end or the other. The length of the line indicates the number value and the arrow indicates the direction in which that number is acting.

Two velocity vectors, such as one representing the velocity of an airplane and one representing the velocity of the wind, can be added together in what is called vector analysis. **Figure 1-6** demonstrates this, with vectors "A" and "B" representing the velocity of the airplane and the wind, and vector "C" being the resultant. With no wind, the speed and direction of the airplane would be that shown by vector "A." When accounting for the wind direction and speed, the airplane ends up flying at the speed and direction shown by vector "C."

Imagine that an airplane is flying in a circular pattern at a constant speed. Because of the circular pattern, the airplane is constantly changing direction, which means the airplane is constantly changing velocity. The reason for this is the fact that velocity includes direction.

To calculate the speed of an object, the distance it travels is divided by the elapsed time. If the distance is measured in miles and the time in hours, the units of speed will be miles per hour (mph). If the distance is measured in feet and the time in seconds, the units of speed will be feet per second (fps). To convert mph to fps, multiply by 1.467. Velocity is calculated the same way, the only difference being it must be recalculated every time the direction changes.

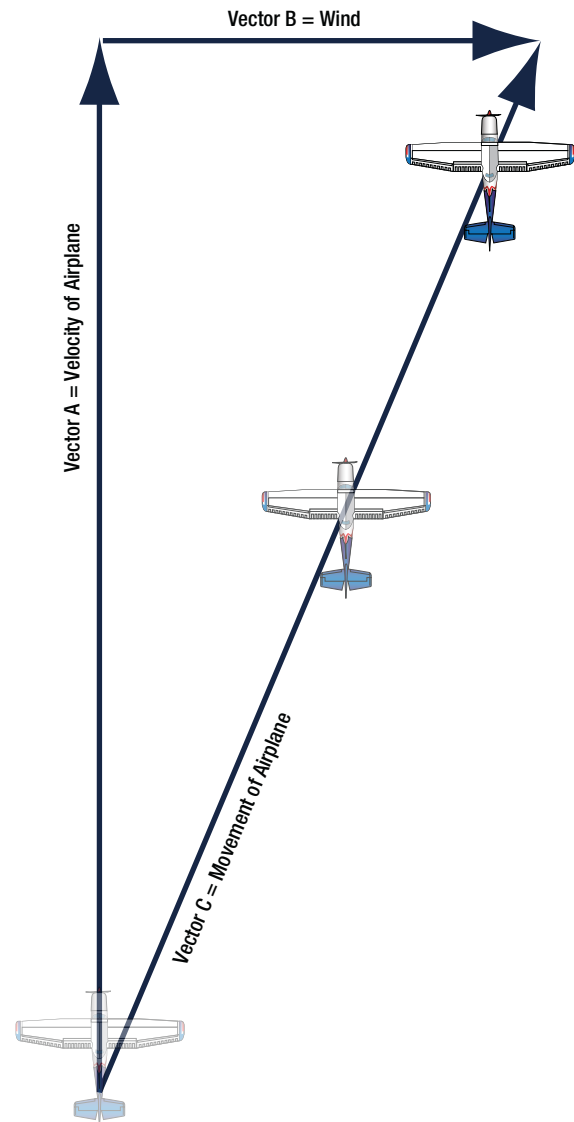

Figure 1-6. Vector analysis for airplane velocity and wind velocity.

## ACCELERATION

Acceleration is defined as the rate of change of velocity. If the velocity of an object is increased from 20 mph to 30 mph, the object has been accelerated. If the increase in velocity is 10 mph in 5 seconds, the rate of change in velocity is 10 mph in 5 seconds, or 2 mph per second. If this were multiplied by 1.467, it could also be expressed as an acceleration of 2.93 feet per second per second (fps/s). By comparison, the acceleration due to gravity is 32.2 fps/s.

To calculate acceleration, the following formula is used:

$$\text{Acceleration (A)} = \frac{\text{Velocity Final (Vf)} - \text{Velocity Initial (Vi)}}{\text{Time (t)}}$$

Example: An Air Force F-15 fighter is cruising at 400 mph. The pilot advances the throttles to full afterburner and accelerates to 1 200 mph in 20 seconds. What is the average acceleration in mph/s and fps/s?

$$A = \frac{V_f - V_i}{t}$$

$$A = \frac{1200 - 400}{20}$$

$$A = 40 \text{ mph/s, or by multiplying by 1.467, } 58.7 \text{ fps/s}$$

In the example above, acceleration was found to be 58.7 fps/s. Since 32.2 fps/s is equal to the acceleration due to gravity, divide the F-15's acceleration by 32.2 to find out how many G forces the pilot is experiencing. In this case, it would be 1.82 Gs.

## GENERAL REQUIREMENTS

Aircraft require thrust to produce enough speed for the wings to provide lift or enough thrust to overcome the weight of the aircraft for vertical take off. For an aircraft to remain in level flight, thrust must be provided that is equal to and in the opposite direction of the aircraft drag. This thrust, or propulsive force, is provided by a suitable type of aircraft heat engine. All heat engines have in common the ability to convert heat energy into mechanical energy by the flow of some fluid mass (generally air) through the engine. In all cases, the heat energy is released at a point in the cycle where the working pressure is high relative to atmospheric pressure.

The propulsive force is obtained by the displacement of a working fluid (again, atmospheric air). This air is not necessarily the same air used within the engine. By displacing air in a direction opposite to that in which the aircraft is propelled, thrust can be developed. This is an application of Newton's third law of motion. It states that for every action there is an equal and opposite reaction. So, as air is being displaced to the rear of the aircraft the aircraft is moved forward by this principle. One misinterpretation of this principle is air is pushing against the air behind the aircraft making it move forward. This is not true.

Rockets in space have no air to push against, yet, they can produce thrust by using Newton's third law. Atmospheric air is the principal fluid used for propulsion in every type of aircraft powerplant except the rocket, in which the total combustion gases are accelerated and displaced. The rocket must provide all the fuel and oxygen for combustion and does not depend on

atmospheric air. A rocket carries its own oxidizer rather than using ambient air for combustion. It discharges the gaseous byproducts of combustion through the exhaust nozzle at an extremely high velocity (action) and it is propelled in the other direction (reaction).

The propellers of aircraft powered by reciprocating or turboprop engines accelerate a large mass of air at a relatively lower velocity by turning a propeller. The same amount of thrust can be generated by accelerating a small mass of air to a very high velocity. The working fluid (air) used for the propulsive force is a different quantity of air than that used within the engine to produce the mechanical energy to turn the propeller.

Turbojets, ramjets, and pulse jets are examples of engines that accelerate a smaller quantity of air through a large velocity change. They use the same working fluid for propulsive force that is used within the engine. One problem with these types of engines is the noise made by the high velocity air exiting the engine. The term turbojet was used to describe any gas turbine engines, but with the differences in gas turbines used in aircraft, this term is used to describe a type of gas turbine that passes all the gases through the core of the engine directly.

Turbojets, ramjets, and pulse jets have very little to no use in modern aircraft due to noise and fuel consumption. Small general aviation aircraft use mostly horizontally opposed reciprocating piston engines. While some aircraft still use radial reciprocating piston engines, their use is very limited. Many aircraft use a form of the gas turbine engine to produce power for thrust. These

engines are normally the turboprop, turboshaft, turbofan, and a few turbojet engines. "Turbojet" is the former term for any turbine engine. Now that there are so many different types of turbine engines, the term used to describe most turbine engines is "gas turbine engine." All four of the previously mentioned engines belong to the gas turbine family.

All aircraft engines must meet certain general requirements of efficiency, economy, and reliability. Besides being economical in fuel consumption, an aircraft engine must be economical in the cost of original procurement and the cost of maintenance; and it must meet exacting requirements of efficiency and low weight-to-horsepower ratio. It must be capable of sustained high-power output with no sacrifice in reliability; it must also have the durability to operate for long periods of time between overhauls. It needs to be as compact as possible, yet have easy accessibility for maintenance. It is required to be as vibration free as possible and be able to cover a wide range of power output at various speeds and altitudes.

These requirements dictate engine fuel delivery systems provide metered fuel at the correct proportion of fuel/air ingested by the engine regardless of the attitude, altitude, or type of weather in which the engine is operated. The engine needs a type of oil system that delivers oil under the proper pressure to lubricate and cool all of the operating parts of the engine when it is running. Also, it must have a system of damping units to damp out the vibrations of the engine when it is operating.

## POWER AND WEIGHT

The useful output of all aircraft powerplants is thrust, the force which propels the aircraft. A reciprocating engine is rated in brake horsepower (bhp), the gas turbine engine is rated in thrust horsepower (thp):

$$Thp = \frac{\text{thrust} \times \text{aircraft speed (mph)}}{375 \text{ mile-pounds per hour}}$$

The value of 375 mile-pounds per hour is derived from the basic horsepower formula as follows:

$$1 \text{ hp} = 33\,000 \text{ ft-lbs per minute}$$

$$33\,000 \times 60 = 1\,980\,000 \text{ ft-lbs per hour}$$

$$\frac{1\,980\,000}{5\,280 \text{ ft in a mile}} = 375 \text{ mile-pounds per hour}$$

One horsepower equals 33 000 ft-lb per minute or 375 mile-pounds per hour. Under static conditions, thrust is figured as equivalent to approximately 2.6 pounds per hour. If a gas turbine is producing 4 000 pounds of thrust and the aircraft in which the engine is installed is traveling at 500 mph, the thp is:

$$\frac{4\,000 \times 500}{375} = 5\,333.33 \text{ thp}$$

It is necessary to calculate the horsepower for each speed of an aircraft, since the horsepower varies with speed. Therefore, it is not practical to try to rate or compare the output of a turbine engine on a horsepower basis. The aircraft engine operates at a relatively high percentage of its maximum power output throughout its service life. The aircraft engine is at full power output whenever a take off is made. It may hold this power for a period of time up to the limits set by the manufacturer.

The engine is seldom held at a maximum power for more than 2 minutes, and usually not that long. Within a few seconds after lift-off, the power is reduced to a power that is used for climbing and that can be maintained for longer periods of time. After the aircraft has climbed to cruising altitude, the power of the engine(s) is further reduced to a cruise power which can be maintained for the duration of the flight.

## FUEL ECONOMY

The basic parameter for describing the fuel economy of aircraft engines is usually specific fuel consumption. Specific fuel consumption for gas turbines is the fuel flow measured in (lbs/hr) divided by thrust (lbs). This is called thrust-specific fuel consumption. Equivalent specific fuel consumption is used for the turboprop engine and is the fuel flow in pounds per hour divided by a turboprop's equivalent shaft horsepower. Comparisons can be made between the various engines on a specific fuel consumption basis.

At low speed, reciprocating and turboprop engines have better economy than the pure turbojet or turbofan engines. However, at high speed, because of losses in propeller efficiency, a reciprocating or turboprop engine's efficiency becomes limited above 400 mph less than that of the turbofan. Equivalent specific fuel consumption is used for the turboprop engine and is the fuel flow in pounds per hour divided by a turboprop's equivalent shaft horsepower. Comparisons can be made between the various engines on a specific fuel consumption basis.

## DURABILITY AND RELIABILITY

Durability and reliability are usually considered identical factors since it is difficult to mention one without including the other. An aircraft engine is reliable when it can perform at the specified ratings in widely varying flight attitudes and in extreme weather conditions. Standards of powerplant reliability are agreed upon by the engine manufacturer, and the airframe manufacturer. The engine manufacturer ensures the reliability of the product by design, research, and testing. Close control of manufacturing and assembly procedures are maintained, and each engine is tested before it leaves the factory.

Durability is the amount of engine life obtained while maintaining the desired reliability. The fact that an engine has successfully completed its type or proof test indicates that it can be operated in a normal manner over a long period before requiring overhaul. However, no definite time interval between overhauls is specified or implied in the engine rating. The time between overhauls (TBO) varies with the operating conditions, such as engine temperatures, amount of time the engine

is operated at high-power settings, and the maintenance received. Recommended TBOs are specified by the engine manufacturer.

Reliability and durability are built into the engine by the manufacturer, but the continued reliability of the engine is determined by the maintenance, overhaul, and operating personnel. Careful maintenance and overhaul methods, thorough periodical and preflight inspections, and strict observance of the operating limits established by the engine manufacturer make engine failure a rare occurrence.

## OPERATING FLEXIBILITY

Operating flexibility is the ability of an engine to run smoothly and give desired performance at all speeds from idling to full-power output. The aircraft engine must also function efficiently through all the variations in atmospheric conditions encountered in widespread operations.

## COMPACTNESS

To affect proper streamlining and balancing of an aircraft, the shape and size of the engine must be as compact as possible. In single-engine aircraft, the shape and size of the engine also affect the view of the pilot, making a smaller engine better from this standpoint, in addition to reducing the drag created by a large frontal area.

Weight limitations, naturally, are closely related to the compactness requirement. The more elongated and spread out an engine is, the more difficult it becomes to keep the specific weight within the allowable limits.

## TYPES AND CONSTRUCTION

In a reciprocating engine, the functions of intake, compression, combustion, and exhaust all take place in the same combustion chamber. Consequently, each must have exclusive occupancy of the chamber during its respective part of the combustion cycle. A significant feature of the gas turbine engine is that separate sections are devoted to each function, and all functions are performed simultaneously without interruption.

A typical gas turbine engine consists of:

1. An air inlet,
2. Compressor section,
3. Combustion section,
4. Turbine section,
5. Exhaust section,
6. Accessory section, and
7. The systems necessary for starting, lubrication, fuel supply, and auxiliary purposes, such as anti-icing, cooling, and pressurization.

Another common nomenclature describing the various sections of a turbine engine are known as the "cold section" and the "hot section". Cold section refers to the parts of the engine from the inlets up through the compressors and/or diffusers. Hot section refers to the areas past the compressors from the combustion chambers through the exhaust.

The major components of all gas turbine engines are basically the same; however, the nomenclature of the component parts of various engines currently in use varies slightly due to the difference in each manufacturer's terminology. These differences are reflected in the applicable maintenance manuals.

## TURBINE ENGINE TYPES

One of the greatest single factors influencing the construction features of any gas turbine engine is the type of compressor or compressors for which the engine is designed. Four types of gas turbine engines are used to propel and power aircraft. They are the turbo-fan, turboprop, turboshaft, and turbojet. (*Figure 1-7*)

The term "turbojet" was used to describe any gas turbine engine used in aircraft. As gas turbine technology evolved, these other engine types were developed to take the place of the pure turbojet engine. The turbojet engine has problems with noise and fuel consumption in the speed range that airliners fly (.8 Mach). Due to these problems, use of pure turbojet engines is very limited. So, almost all airliner-type aircraft use a turbofan engine.

Turbofan engines were developed to turn a large fan or set of fans at the front of the engine and produces about 80 percent of the thrust from the engine. This engine is quieter and has better fuel consumption in the high sub-Mach speed range. Turbofan engines have more than one shaft in the engine; many are two-shaft engines. This means that there are compressors and turbines that drive it. These two shafted engines use two spools (a spool is a compressor and a shaft and turbines that driven that compressor). In a two-spool engine, there is a high- pressure spool and a low-pressure spool. The low-pressure spool generally contains the fan(s) and the turbine stages it takes to drive them. The high-pressure spool is the high-pressure compressor, shaft, and turbines. This spool makes up the core of the engine, and this is where the combustion section is located.

The high-pressure spool is also referred to as the gas generator because it contains the combustion section.

## BYPASS RATIO

Turbofan engines can be low bypass or high bypass. The amount of air that is bypassed around the core of the engine determines the bypass ratio. As can be seen in *Figure 1-8*, the air generally driven by the fan does not pass through the internal working core of the engine. The amount of air flow in lbs/sec from the fan bypass compared to the amount of air that flows through the core of the engine is the bypass ratio.

$$\text{Bypass ratio} = \frac{100 \text{ lb/sec flow fan}}{20 \text{ lb/sec flow core}} = 5:1 \text{ bypass ratio}$$

Turbofan engines are generally categorized as high bypass or low bypass in accordance with their bypass ratios. Most transport category aircraft use high bypass engines. Some low-bypass turbofan engines are used in speed ranges above .8 Mach (military aircraft). These engines use augmenters or afterburners to increase thrust. By adding more fuel nozzles and a flame holder in the exhaust system extra fuel can be sprayed and burned which can give large increases in thrust for short amounts of time.

The turbofan gas turbine engine is, in principle, the same as a turboprop, except that the propeller is replaced by a duct enclosed axial-flow fan. (*Figure 1-9*)

The fan can be a part of the first-stage compressor blades or can be mounted as a separate set of fan blades. The blades can be mounted forward of the compressor.

The general principle of the fan engine is to convert more of the fuel energy into pressure. With more of the energy converted to pressure, a greater product of pressure times area can be achieved. One of the major advantages is turbofan production of this additional thrust without increasing fuel flow. The end result is fuel economy with the consequent increase in range. Because more of the fuel energy is turned into pressure in the turbofan engine, additional stages must be added in the turbine section to provide the power to drive the fan. This means there is less energy left over and less thrust from the core exhaust gases. Also, in a mixed-exhaust nozzle (where fan air and core air mix in a common nozzle before entering ambient conditions) the exhaust

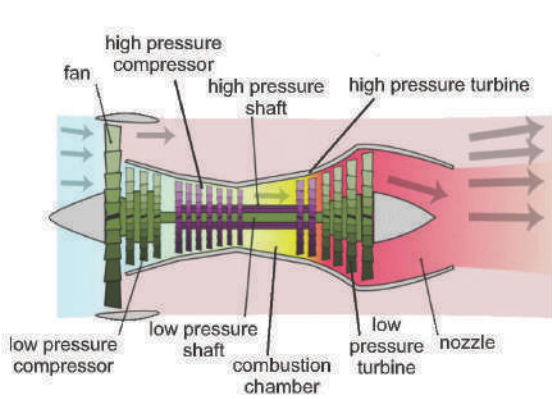

turbo fan

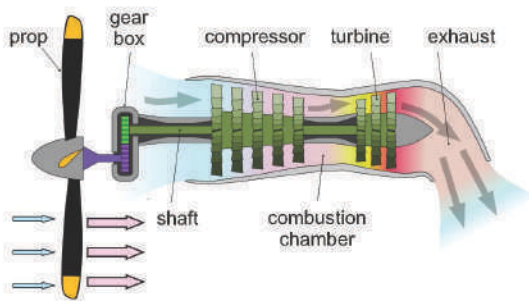
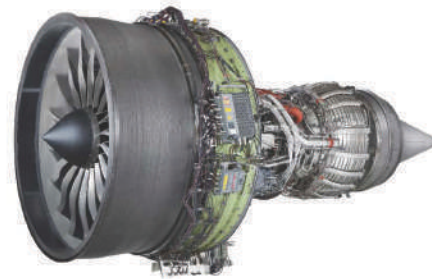

turbo prop

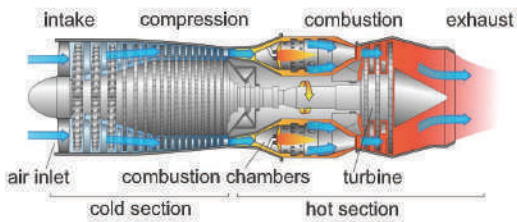
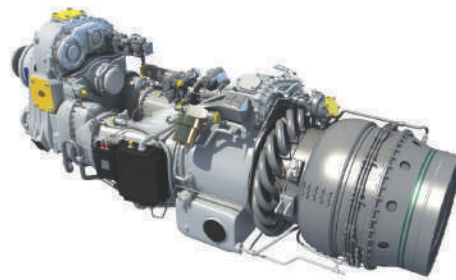

turbo jet

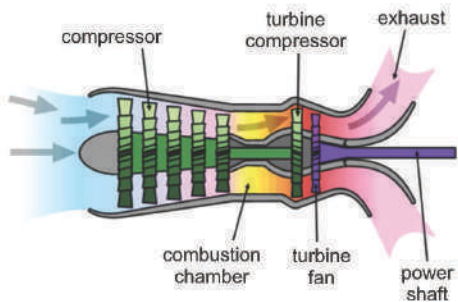
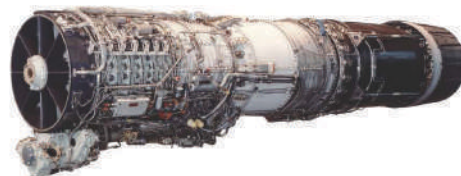

turbo shaft

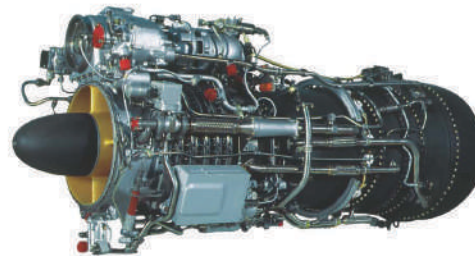

Figure 1-7. The four primary types of gas turbine engines.

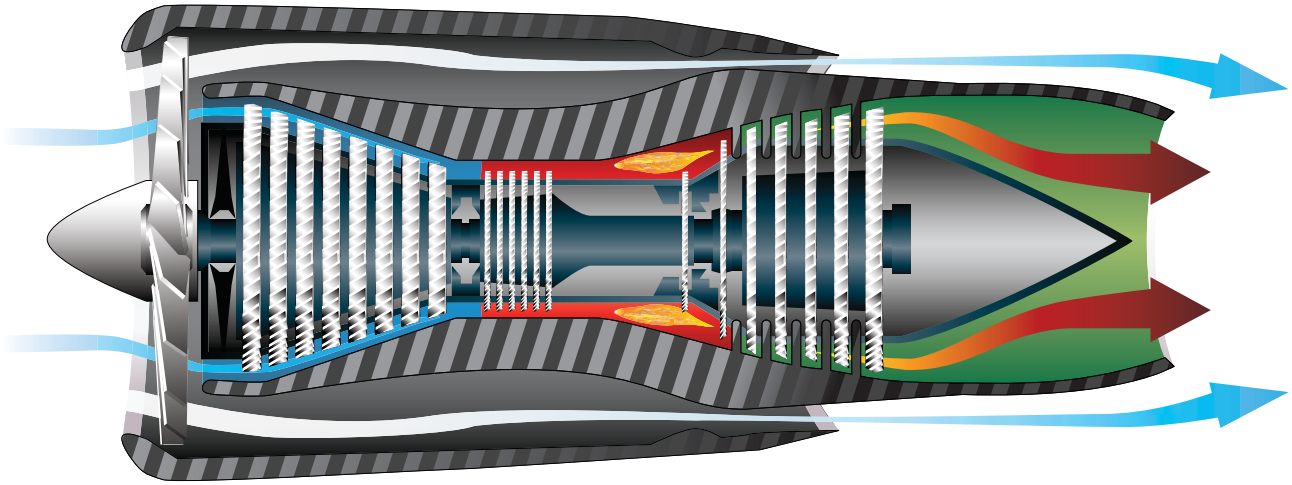

Figure 1-8. Fan airflow and core airflow of a turbofan engine.

nozzle must be larger in area. The result is that the fan develops most of the thrust. The thrust produced by the fan more than makes up for the decrease in thrust of the core (gas generator) of the engine. Depending on the fan design and bypass ratio, it produces 80 percent of the turbofan engine's total thrust.

Two different exhaust nozzle designs are used with turbofan engines. The air leaving the fan can be ducted overboard by a separate fan nozzle (*Figure 1-7*), or it can be ducted along the outer case of the basic engine to be discharged through the mixed nozzle (core and fan exhaust together). The fan air is either mixed with the exhaust gases before it is discharged (mixed or common nozzle), or it passes directly to the atmosphere without prior mixing (separate nozzle). Turbofans are the most widely used gas turbine engine for air transport aircraft.

The turbofan is a compromise between the good operating efficiency and high thrust capability of a turboprop and the high speed, high altitude capability of a turbojet. The turboprop engine is a gas turbine engine that turns a propeller through a speed reduction gear box. This type of engine is most efficient in the 300 to 400 mph speed range and can use shorter runways that other aircraft. Approximately 80 to 85 percent of the energy developed by the gas turbine engine is used to drive the propeller. The rest of the available energy exits the exhaust as thrust.



Figure 1-9. A turbofan engine.

The turboshaft engine used in aviation is a gas turbine engine made to transfer horsepower to a shaft to operate something other than a propeller. They are used primarily to power helicopters and auxiliary power units (APU's). APU's are used on large aircraft to provide electrical power and bleed air on the ground and emergency backup power in flight.

**Question: 1-1**

Potential energy may be classified as stored energy due to the position of a body, due to distortion of an elastic body, or due to work produced by \_\_\_\_\_ action.

**Question: 1-5**

\_\_\_\_\_ may be defined as a continuing change of position or place, or as the process in which a body undergoes displacement.

**Question: 1-2**

What is the formula for calculating the kinetic energy for something in motion?

**Question: 1-6**

Acceleration is defined as the rate of change of \_\_\_\_\_.

**Question: 1-3**

For work, power, or torque to exist, there has to be a \_\_\_\_\_ that initiates the process.

**Question: 1-7**

A reciprocating engine is rated in brake horsepower (bhp), the gas turbine engine is rated in \_\_\_\_\_.

**Question: 1-4**

Work can be calculated by multiplying the force  $\times$  distance. To calculate power, what consideration is added to this formula?

**Question: 1-8**

A significant feature of the gas turbine engine is that separate sections are devoted to each function, and all functions are performed \_\_\_\_\_ without interruption.



## ANSWERS

*Answer: 1-1*  
chemical.

*Answer: 1-5*  
Motion.

*Answer: 1-2*  
Kinetic Energy =  $\frac{1}{2}$  Mass  $\times$  Velocity<sup>2</sup>.

*Answer: 1-6*  
velocity.

*Answer: 1-3*  
force.

*Answer: 1-7*  
thrust horsepower (thp).

*Answer: 1-4*  
Time.

*Answer: 1-8*  
simultaneously.



PART-66 SYLLABUS LEVELS  
 CERTIFICATION CATEGORY → **A1** **B1**

**Sub-Module 02**  
**ENGINE PERFORMANCE**

Knowledge Requirements

*15.2 - Engine Performance*

Gross thrust, net thrust, choked nozzle thrust, thrust distribution, resultant thrust, thrust horsepower, equivalent shaft horsepower, specific fuel consumption;  
 Engine efficiencies;  
 Bypass ratio and engine pressure ratio;  
 Pressure, temperature and velocity of the gas flow;  
 Engine ratings, static thrust, influence of speed, altitude and hot climate, flat rating, limitations.

	A1	B1
	-	2

**Level 2**

A general knowledge of the theoretical and practical aspects of the subject and an ability to apply that knowledge.

*Objectives:*

- (a) The applicant should be able to understand the theoretical fundamentals of the subject.
- (b) The applicant should be able to give a general description of the subject using, as appropriate, typical examples.
- (c) The applicant should be able to use mathematical formula in conjunction with physical laws describing the subject.
- (d) The applicant should be able to read and understand sketches, drawings and schematics describing the subject.
- (e) The applicant should be able to apply his knowledge in a practical manner using detailed procedures.

# ENGINE PERFORMANCE

## TURBINE ENGINE OPERATING PRINCIPLES

The principle used by a gas turbine engine as it provides force to move an airplane is based on Newton's law of momentum. This law states that for every action there is an equal and opposite reaction; therefore, if the engine accelerates a mass of air (action), it applies a force on the aircraft (reaction). The turbofan generates thrust by giving a relatively slower acceleration to a large quantity of air. The old pure turbojet engine achieves thrust by imparting greater acceleration to a smaller quantity of air. This was its main problem with fuel consumption and noise.

The mass of air is accelerated within the engine by the use of a continuous-flow cycle. Ambient air enters the inlet diffuser where it is subjected to changes in temperature, pressure, and velocity due to ram effect. The compressor then increases pressure and temperature of the air mechanically. The air continues at constant pressure to the burner section where its temperature is increased by combustion of fuel. The energy is taken from the hot gas by expanding through a turbine which drives the compressor, and by expanding through an exhaust nozzle designed to discharge the exhaust gas at high velocity to produce thrust.

The high velocity gases from the engine may be considered continuous, imparting this force against the aircraft in which it is installed, thereby producing thrust. The formula for thrust can be derived from Newton's second law, which states that force is proportional to the product of mass and acceleration. This law is expressed in the formula:

$$F = M \times A$$

Where:

F = force in pounds

M = mass in pounds per seconds

A = acceleration in feet per seconds

In the above formula, mass is similar to weight, but it is actually a different quantity. Mass refers to the quantity of matter, while weight refers to the pull of gravity on that quantity of matter. At sea level under standard conditions, 1 pound of mass has a weight of 1 pound. To calculate the acceleration of a given mass, the

gravitational constant is used as a unit of comparison. The force of gravity is 32.2 feet per second squared (ft/sec<sup>2</sup>). This means that a free falling 1 pound object accelerates at the rate of 32.2 feet per second each second that gravity acts on it. Since the object mass weighs 1 pound, which is also the actual force imparted to it by gravity, it can be assumed that a force of 1 pound accelerates an object at the rate of 32.2 ft/sec<sup>2</sup>.

Also, a force of 10 pound accelerates a mass of 10 pound at the rate of 32.2 ft/sec<sup>2</sup>. This is assuming there is no friction or other resistance to overcome. It is now apparent that the ratio of the force (in pounds) is to the mass (in pounds) as the acceleration in ft/sec<sup>2</sup> is to 32.2. Using M to represent the mass in pounds, the formula may be expressed thus:

$$\frac{F}{M} = \frac{A}{G} \text{ or } F = \frac{MA}{G}$$

Where:

F = force

M = mass

A = acceleration

G = gravity

In any formula involving work, the time factor must be considered. It is convenient to have all time factors in equivalent units (i.e., seconds, minutes, or hours). In calculating jet thrust, the term "pounds of air per second" is convenient, since the second is the same unit of time used for the force of gravity.

## THRUST

Using the formula below, compute the force necessary to accelerate a mass of 50 pounds by 100 ft/sec<sup>2</sup>.

$$F = \frac{MA}{G}$$

$$F = \frac{50 \text{ lb} \times 100 \text{ ft/sec}^2}{32.2 \text{ ft/sec}^2}$$

$$F = \frac{5000 \text{ lb-ft/sec}^2}{32.2 \text{ ft/sec}^2}$$

$$F = 155 \text{ lb}$$

This illustrates that if the velocity mass per second is increased by 100, the resulting thrust is 155 pounds.

Since the turbojet engine accelerates air, the following formula can be used to determine jet thrust:

$$F = \frac{M_s (V_2 - V_1)}{G}$$

Where:

F = force in pounds

M<sub>s</sub> = mass flow in lb/sec

V<sub>1</sub> = inlet velocity

V<sub>2</sub> = jet velocity (exhaust)

V<sub>2</sub> - V<sub>1</sub> = change in velocity;  
difference between inlet velocity and jet velocity

G = Acceleration of gravity or 32.2 ft/sec<sup>2</sup>

As an example, to use the formula for changing the velocity of 100 pounds of mass airflow per second from 600 ft/sec to 800 ft/sec, the formula can be applied as follows:

$$F = \frac{100 \text{ lb/sec} (800 \text{ ft/sec} - 600 \text{ ft/sec})}{32.2 \text{ ft/sec}^2}$$

$$F = \frac{20\,000 \text{ lb/sec}}{32.2 \text{ ft/sec}^2}$$

$$F = 621 \text{ lb}$$

As shown by the formula, if the mass airflow per second and the difference in the velocity of the air from the intake to the exhaust are known, it is easy to compute the force necessary to produce the change in the velocity. Therefore, the thrust of the engine must be equal to the force required to accelerate the air mass through the engine. Then, by using the symbol "Fn" for thrust pounds, the formula becomes:

$$F_n = \frac{M_s (V_2 - V_1)}{G}$$

Thrust of a gas turbine engine can be increased by two methods: increasing the mass flow of air through the engine or increasing the gas velocity. If the velocity of the turbojet engine remains constant with respect to the aircraft, the thrust decreases if the speed of the aircraft is increased. This is because V<sub>1</sub> increases in value. This does not present a serious problem, however, because as

the aircraft speed increases, more air enters the engine, and jet velocity increases. The resultant net thrust is almost constant with increased airspeed.

## THE BRAYTON CYCLE

The Brayton cycle is the name given to the thermodynamic cycle of a gas turbine engine to produce thrust. This is a variable volume constant-pressure cycle of events and is commonly called the constant-pressure cycle. A more recent term is "continuous combustion cycle." The four continuous and constant events are intake, compression, expansion (includes power), and exhaust. These cycles are discussed as they apply to a gas-turbine engine. (*Figure 2-1*)

In the intake cycle, air enters at ambient pressure and a constant volume. It leaves the intake at an increased pressure and a decrease in volume. At the compressor section, air is received from the intake at an increased pressure, slightly above ambient, and a slight decrease in volume. Air enters the compressor where it is compressed. It leaves the compressor with a large increase in pressure and decrease in volume, created by the mechanical action of the compressor. The next step, expansion, takes place in the combustion chamber by burning fuel, which expands the air by heating it. The pressure remains relatively constant, but a marked increase in volume takes place. The expanding gases move rearward through the turbine assembly and are converted from velocity energy to mechanical energy by the turbine. The exhaust section, which is a convergent duct, converts the expanding volume and decreasing pressure of the gases to a final high velocity. The force created inside the engine to keep this cycle continuous has an equal and opposite reaction (thrust) to move the aircraft forward.

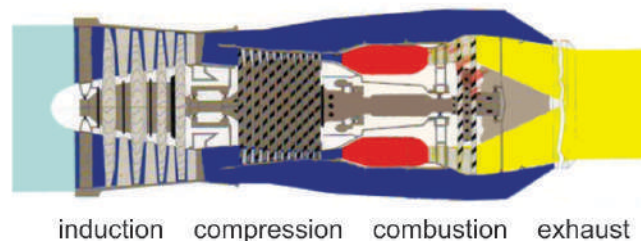

## THE BRAYTON CYCLE

Figure 2-1. The Brayton Cycle.

Bernoulli's principle (whenever a stream of any fluid has its velocity increased at a given point, the pressure of the stream at that point is less than the rest of the stream) is applied to gas turbine engines through the design of convergent and divergent air ducts. The convergent duct increases velocity and decreases pressure. The divergent duct decreases velocity and increases pressure. The convergent principle is usually used for the exhaust nozzle. The divergent principle is used in the compressor and diffuser where the air is slowing and pressurizing.

When an exhaust nozzle is convergent the velocity of gases leaving the rear of the engine increases. This is desirable for the development of maximum thrust. As the gases approach the speed of sound, the nozzle is said to be choked and choked nozzle thrust is produced. This means the highest efficiency has been obtained in the engine for subsonic flight. However, at the speed of sound, the exhaust gases will produce a shock wave which deteriorates performance.

Gross or static thrust is developed when the engine is on the ground and stationary. As will be seen in the next section, velocity of the airflow entering the engine changes and affects thrust when the aircraft is in flight.

The thrust developed by an engine can be thought of as being contributed by the various sections of the engine during the continuous combustion cycle. Thrust distribution can be seen by examining the loads produced in a representative turbojet engine as shown in *Figure 2-2*.

Note that in the forward part of the engine, due to Newton's second law, loads are in the forward direction. As the gases go throughout the nozzle guide vanes and the turbine, loads shift to the rearward direction. Power is extracted and drag occurs. Drag, which continues as the gases make their way throughout the exhaust section, is a significant force. The resultant thrust is in the forward direction.

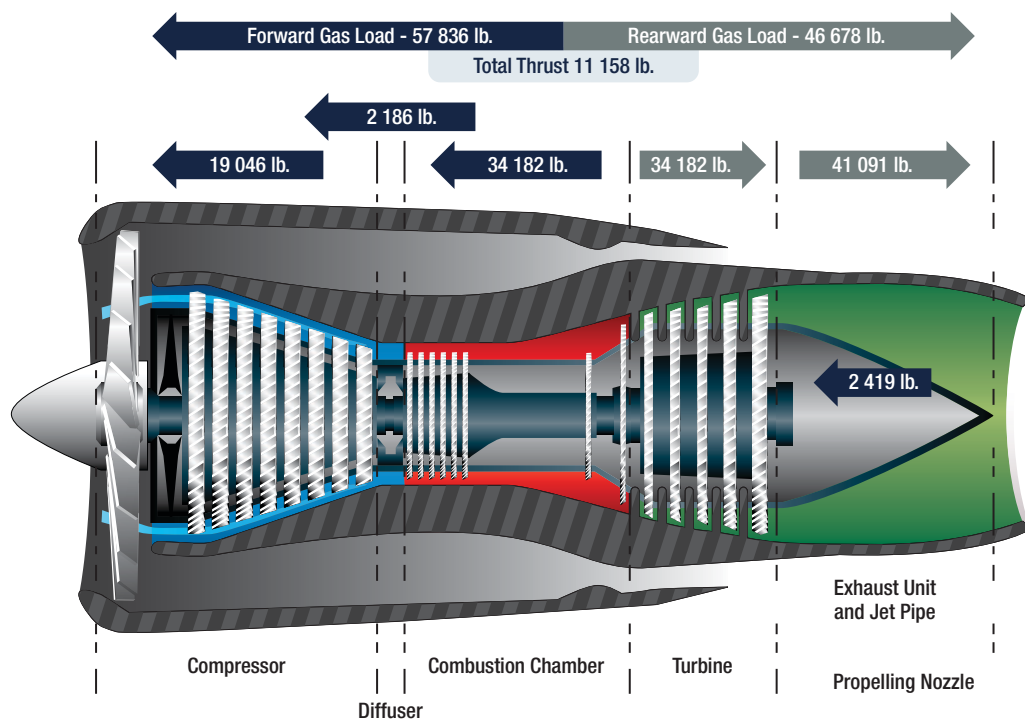

Figure 2-2. Forward and rearward load production on a turbojet engine.

## GAS TURBINE ENGINE PERFORMANCE

Thermal efficiency is a prime factor in gas turbine performance. It is the ratio of network produced by the engine to the chemical energy supplied in the form of fuel. The three most important factors affecting the thermal efficiency are turbine inlet temperature, compression ratio, and the component efficiencies of the compressor and turbine. Other factors that affect thermal efficiency are compressor inlet temperature and combustion efficiency. *Figure 2-3* shows the effect that changing compression ratio (compressor pressure ratio) has on thermal efficiency when compressor inlet temperature and the component efficiencies of the compressor and turbine remain constant.

The effects that compressor and turbine component efficiencies have on thermal efficiency when turbine and compressor inlet temperatures remain constant are shown in *Figure 2-4*. In actual operation, the turbine engine exhaust temperature varies directly with turbine inlet temperature at a constant compression ratio.

RPM is a direct measure of compression ratio; therefore, at constant rpm, maximum thermal efficiency can be obtained by maintaining the highest possible exhaust temperature. Since engine life is greatly reduced at high turbine inlet temperatures, the operator should not exceed the exhaust temperatures specified for continuous operation. *Figure 2-5* illustrates the effect of turbine inlet temperature on turbine blade life. In the previous discussion, it was assumed that the state of the air at the inlet to the compressor remains constant. Since this is a practical application of a turbine engine, it becomes necessary to analyze the effect of varying inlet conditions on the thrust or power produced. The three principal variables that affect inlet conditions are the speed of the aircraft, the altitude of the aircraft, and the ambient temperature. To make the analysis simpler, the combination of these three variables can be represented by a single variable called stagnation density.

The power produced by a turbine engine is proportional to the stagnation density at the inlet. The next three illustrations show how changing the density by varying altitude, airspeed, and outside air temperature affects the power level of the engine. *Figure 2-6* shows that the thrust output improves rapidly with a reduction in outside air temperature (OAT) at constant altitude,

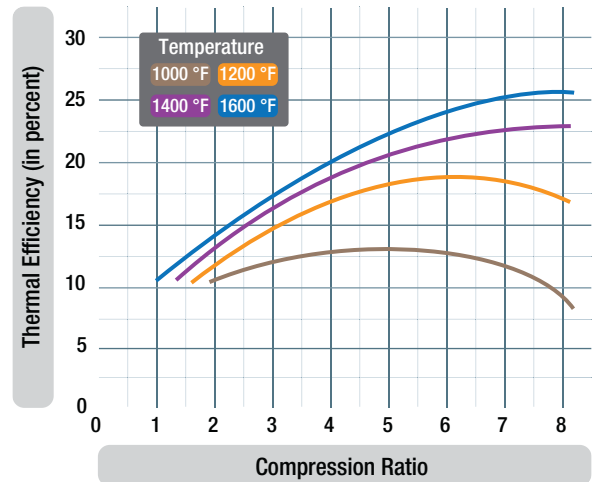

Figure 2-3. The effect of compression ratio on thermal efficiency.

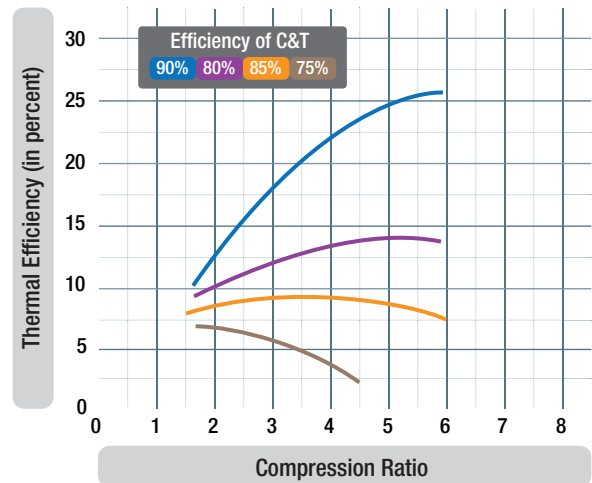

Figure 2-4. Turbine and compressor efficiency vs. thermal efficiency.

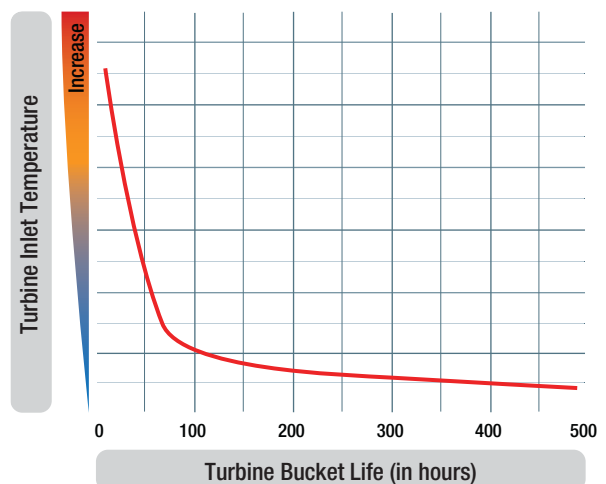

Figure 2-5. Effect of turbine inlet temperature on turbine bucket life.

rpm, and airspeed. This increase occurs partly because the energy required per pound of airflow to drive the compressor varies directly with the temperature, leaving more energy to develop thrust. In addition, the thrust output increases since the air at reduced temperature has an increased density. The increase in density causes the mass flow through the engine to increase.

The altitude effect on thrust, as shown in *Figure 2-7*, can also be discussed as a density and temperature effect. In this case, an increase in altitude causes a decrease in pressure and temperature. Since the temperature lapse rate is lower than the pressure lapse rate as altitude is increased, the density is decreased. Although the decreased temperature increases thrust, the effect of decreased density more than offsets the effect of the colder temperature. The net result of increased altitude is a reduction in the thrust output.

The effect of airspeed on the thrust of a gas-turbine engine is shown in *Figure 2-8*. To explain the airspeed effect, it is necessary to understand first the effect of airspeed on the factors that combine to produce net thrust: specific thrust and engine airflow. Specific thrust is the net thrust in pounds developed per pound of airflow per second. It is the remainder of specific gross thrust minus specific ram drag. As airspeed is increased, ram drag increases rapidly. The exhaust velocity remains relatively constant; thus, the effect of the increase in airspeed results in decreased specific thrust. (*Figure 2-8*) In the low-speed range, the specific thrust decreases faster than the airflow increases and causes a decrease in net thrust. As the airspeed increases into the higher range, the airflow increases faster than the specific thrust decreases and causes the net thrust to increase until sonic velocity is reached. The effect of the combination on net thrust is illustrated in *Figure 2-9*.

## RAM RECOVERY

A rise in pressure above existing outside atmospheric pressure at the engine inlet, as a result of the forward velocity of an aircraft, is referred to as ram pressure. Since any ram effect causes an increase in compressor entrance pressure over atmospheric, the resulting pressure rise causes an increase in the mass airflow and gas velocity, both of which tend to increase thrust. Although ram effect increases engine thrust, the thrust being produced by the engine decreases for a given throttle setting as the aircraft gains airspeed. Therefore,

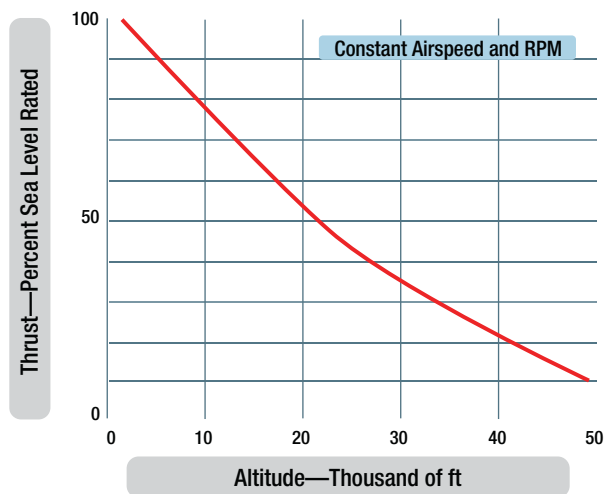

Figure 2-7. Effect of altitude on thrust output.

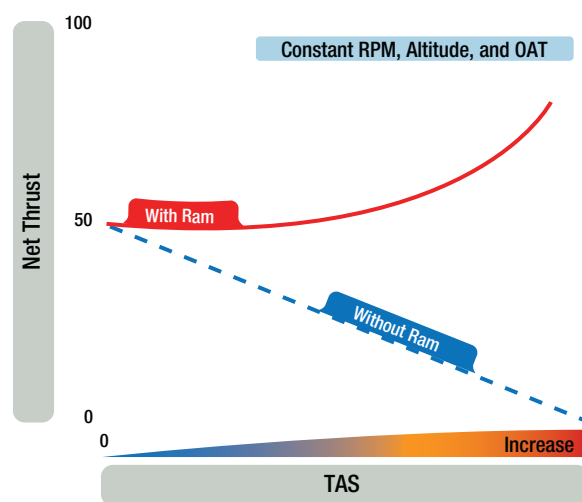

Figure 2-8. Effect of airspeed on net thrust.

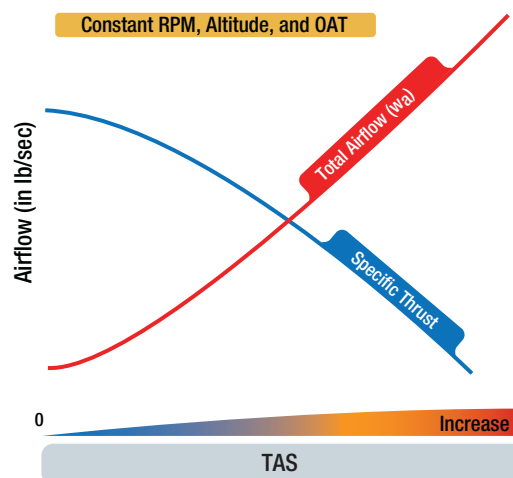

Figure 2-9. Effect of airspeed on specific thrust and total engine airflow.

two opposing trends occur when an aircraft's speed is increased. What actually takes place is the net result of these two different effects. An engine's thrust output temporarily decreases as aircraft speed increases from static, but soon ceases to decrease. Moving toward higher speeds, thrust output begins to increase again due to the increased pressure of ram recovery.

## ENGINE RATINGS

The flat rating of a turbine engine is the thrust performance that is guaranteed by the manufacturer for a new engine under specific operating conditions, such as takeoff, maximum continuous climb, and cruise power settings. The turbine inlet temperature is proportional to the energy available to turn the turbine. This means that the hotter the gases are that are entering the turbine section of the engine, the more power is available to turn the turbine wheel. The exhaust temperature is proportional to the turbine inlet temperature. Regardless of how or where the exhaust temperature is taken on the engine for the flight deck reading, this temperature is proportional to the temperature of the exhaust gases entering the first stage of inlet guide vanes.

A higher EGT corresponds to a larger amount of energy to the turbine so it can turn the compressor faster. This works fine until the temperature reaches a point when the turbine inlet guide vanes start to be damaged. EGT must be held constant, or lowered as the result of a prolonged hot section life and, at the same time, provide the thrust to meet the certification requirements.

Performance rating for turbine engines are given by the manufacturer for during takeoff, maximum continuous operation, maximum climb, maximum cruise and idle.

## ENGINE PRESSURE RATIO

The engine pressure ratio (EPR) of an operating turbine engine is a reflection of how much power is being developed. EPR is a comparison of the pressure at the inlet of the compressor to the pressure at the turbine exhaust area. These two pressure levels are taken with pick-ups installed in the engine. The sensors are known as the P2 and P7 sensors. An EPR gauge is located on the flight deck. It is used to set the power for takeoff on many types of aircraft.





**Question: 2-1**

The principle used by a gas turbine engine as it provides force to move an airplane is based on Newton's law of momentum which states \_\_\_\_\_.

**Question: 2-5**

A rise in pressure above existing outside atmospheric pressure at the engine inlet, as a result of the forward velocity of an aircraft, is referred to as \_\_\_\_\_.

**Question: 2-2**

Thrust of a gas turbine engine can be increased by two methods: increasing the mass flow of air through the engine or increasing \_\_\_\_\_.

**Question: 2-6**

Engine pressure ratio (EPR) is a comparison of the pressure at the inlet of the compressor to the pressure \_\_\_\_\_.

**Question: 2-3**

A convergent duct \_\_\_\_\_ velocity and \_\_\_\_\_ pressure.

**Question: 2-7**

The four elements of the Brayton Cycle are: \_\_\_\_\_, \_\_\_\_\_, \_\_\_\_\_, and \_\_\_\_\_.

**Question: 2-4**

The three most important factors affecting the thermal efficiency are turbine inlet temperature, \_\_\_\_\_ ratio, and the component efficiencies of the compressor and turbine.

**Question: 2-8**

The four main factors which effect turbine engine performance are: \_\_\_\_\_, \_\_\_\_\_, \_\_\_\_\_, and \_\_\_\_\_.

## ANSWERS

*Answer: 2-1*

for every action there is an equal and opposite reaction.

*Answer: 2-5*

ram pressure.

*Answer: 2-2*

the gas velocity.

*Answer: 2-6*

at the turbine exhaust area.

*Answer: 2-3*

increases.

decreases.

*Answer: 2-7*

induction, compression, combustion, exhaust

*Answer: 2-4*

compression.

*Answer: 2-8*

turbine inlet temperature, compression ratio,  
compressor efficiency, turbine efficiency



# GAS TURBINE ENGINE

INLET

## SUB-MODULE 03

PART-66 SYLLABUS LEVELS

CERTIFICATION CATEGORY →

A1	B1
2	2

INLET

### Sub-Module 03

#### INLET

Knowledge Requirements

#### 15.3 - Inlet

- Compressor inlet ducts;
- Effects of various inlet configurations;
- Ice protection.

#### Level 2

A general knowledge of the theoretical and practical aspects of the subject and an ability to apply that knowledge.

#### Objectives:

- (a) The applicant should be able to understand the theoretical fundamentals of the subject.
- (b) The applicant should be able to give a general description of the subject using, as appropriate, typical examples.
- (c) The applicant should be able to use mathematical formula in conjunction with physical laws describing the subject.
- (d) The applicant should be able to read and understand sketches, drawings and schematics describing the subject.
- (e) The applicant should be able to apply his knowledge in a practical manner using detailed procedures.

---

## INLETS AND ACCESSORY

### AIR ENTRANCE

The air entrance is designed to conduct incoming air to the compressor with a minimum energy loss resulting from drag or ram pressure loss; that is, the flow of air into the compressor should be free of turbulence to achieve maximum operating efficiency. Proper inlet design contributes materially to aircraft performance by increasing the ratio of compressor discharge pressure to duct inlet pressure.

This is also referred to as the compressor pressure ratio. This ratio is the outlet pressure divided by the inlet pressure. The amount of air passing through the engine is dependent upon three factors:

1. The compressor speed (rpm)
2. The forward speed of the aircraft
3. The density of the ambient (surrounding) air

Turbine inlet type is dictated by the type of gas turbine engine. A high-bypass turbofan engine inlet is completely different from a turboprop or turboshaft inlet. Large gas turbine powered aircraft almost always have a turbofan engine. The inlet on this type of engine is bolted to the front (A flange) of the engine. These engines are mounted on the wings, or nacelles, on the aft fuselage, and a few are in the vertical fin. A typical turbofan inlet can be seen in *Figure 3-1*.

Since on most modern turbofan engines the huge fan is the first part of the aircraft the incoming air comes into contact with, icing protection must be provided. This prevents chunks of ice from forming on the leading edge of the inlet, breaking loose, and damaging the fan. Warm air is bled from the engine's compressor and is ducted through the inlet to prevent ice from forming. If inlet guide vanes are used to straighten the air flow, then they also have anti-icing air flowing through them. The



Figure 3-1. Typical turbofan inlet.

inlet also contains some sound-reducing materials that absorb the fan noise and make the engine quieter.

Turboprops and turboshafts can use an inlet screen to help filter out ice or debris from entering the engine. A deflector vane and a heated inlet lip are used to prevent ice or large chunks from entering the engine.

On military aircraft, the divided entrance permits the use of very short ducts with a resultant small pressure drop through skin friction. Military aircraft can fly at speeds above Mach 1, but the airflow through the engine must always stay below Mach 1. Supersonic air flow in the engine would destroy the engine. By using convergent and divergent shaped ducts, the air flow is controlled and dropped to subsonic speeds before entering the engine. Supersonic inlets are used to slow the incoming engine air to less than Mach 1 before it enters the engine.

---

## TURBINE ENGINE INLET SYSTEMS

The engine inlet of a turbine engine is designed to provide a relatively distortion-free flow of air, in the required quantity, to the inlet of the compressor. (*Figure 3-2*) Many engines use inlet guide vanes (IGV) to help straighten the airflow and direct it into the first stages of the compressor. A uniform and steady airflow is necessary to avoid compressor stall (airflow tends to

stop or reverse direction of flow) and excessive internal engine temperatures in the turbine section. Normally, the air-inlet duct is considered an airframe part and not a part of the engine. However, the duct is very important to the engine's overall performance and the engine's ability to produce an optimum amount of thrust.



Figure 3-2. Inlet fan blades and guide vanes (inner circle) on a GEEnx engine.

A gas turbine engine consumes considerable more airflow than a reciprocating engine. The air entrance passage is correspondingly larger. Furthermore, it is more critical in determining engine and aircraft performance, especially at high airspeeds. Inefficiencies of the inlet duct result in successively magnified losses through other components of the engine. The inlet varies according to the type of turbine engine. Small turboprop and turboshaft engines have a lower airflow than large turbofan engines which require a completely different type of inlet. Many turboprop, auxiliary power units, and turboshaft engines use screens that cover the inlet to prevent foreign object damage (FOD).

As aircraft speed increases, thrust tends to decrease somewhat; as the aircraft speed reaches a certain point, ram recovery compensates for the losses caused by the increases in speed. The inlet must be able to recover as much of the total pressure of the free airstream as possible. As air molecules are trapped and begin to be compressed in the inlet, much of the pressure loss is recovered. This added pressure at the inlet of the engine increases the pressure and airflow to the engine. This is known as "ram recovery" or "total pressure recovery." The inlet duct must uniformly deliver air to the compressor inlet with as little turbulence and pressure variation as possible. The engine inlet duct must also hold the drag effect on the aircraft to a minimum.

Air pressure drop in the engine inlet is caused by the friction of the air along both sides of the duct and by the bends in the duct system. Smooth flow depends upon keeping the amount of turbulence to a minimum as the air enters the duct. On engines with low flow

rates, turning the airflow allows the engine nacelle to be smaller and have less drag. On turbofan engines, the duct must have a sufficiently straight section to ensure smooth, even airflow because of the high airflows. The choice of configuration of the entrance to the duct is dictated by the location of the engine within the aircraft and the airspeed, altitude, and attitude at which the aircraft is designed to operate.

## DIVIDED-ENTRANCE DUCT

The requirements of high-speed, single or twin engine military aircraft, in which the pilot sits low in the fuselage and close to the nose, render it difficult to employ the older type single-entrance duct, which is not used on modern aircraft. Some form of a divided duct, which takes air from either side of the fuselage, has become fairly widely used. This divided duct can be either a wing-root inlet or a scoop at each side of the fuselage. (*Figure 3-3*)

Either type of duct presents more problems to the aircraft designer than a single-entrance duct because of the difficulty of obtaining sufficient air scoop area without imposing prohibitive amounts of drag. Internally, the problem is the same as that encountered with the single entrance duct: to construct a duct of reasonable length with as few bends as possible. Scoops at the sides of the fuselage are often used. These side scoops are placed as far forward as possible to permit a gradual bend toward the compressor inlet, making the airflow characteristics approach those of a single-entrance duct. A series of turning vanes is sometimes placed in the side-scoop inlet to assist in straightening the incoming airflow and to prevent turbulence.



Figure 3-3. An example of a divided-entrance duct.

## VARIABLE-GEOMETRY DUCT

The main function of an inlet duct is to furnish the proper amount of air to the engine inlet. In a typical military aircraft using a turbojet or low bypass turbofan engine, the maximum airflow requirements are such that the Mach number of the airflow directly ahead of the face of the engine is less than Mach 1. Airflow through the engine must be less than Mach 1 at all times. Therefore, under all flight conditions, the velocity of the airflow as it enters the air-inlet duct must be reduced through the duct before the airflow is ready to enter the compressor. To accomplish this, inlet ducts are designed to function as diffusers, decreasing the velocity and increasing the static pressure of the air passing through them. (*Figure 3-4*)

As with military supersonic aircraft, a diffuser progressively decreases in area in the downstream direction. Therefore, a supersonic inlet duct follows this general configuration until the velocity of the incoming air is reduced to Mach 1. The aft section of the duct then increases in area, since this part must act as a subsonic diffuser. (*Figure 3-5*)

In practice, inlet ducts for supersonic aircraft follows this general design only as much as practical, depending upon the design features of the aircraft. For very high speed aircraft, the inside area of configuration of the duct is changed by a mechanical device as the speed of the aircraft increases or decreases. A duct of this type is usually known as a variable-geometry inlet duct.

Military aircraft use the three methods described above to diffuse the inlet air and slow the inlet airflow at supersonic flight speeds. One is to vary the area, or geometry, of the inlet duct either by using a movable restriction, such as a ramp or wedge, inside the duct. Another system is some sort of a variable airflow bypass arrangement, which extracts part of the inlet airflow from the duct ahead of the engine. In some cases, a combination of both systems is used.

The third method is the use of a shock wave in the airstream. A shock wave is a thin region of discontinuity in a flow of air or gas, during which the speed, pressure, density, and temperature of the air or gas undergo a sudden change. Stronger shock waves produce larger changes in the properties of the air or gas. A shock wave is willfully set up in the supersonic flow of the air entering the duct, by means of some restriction or small

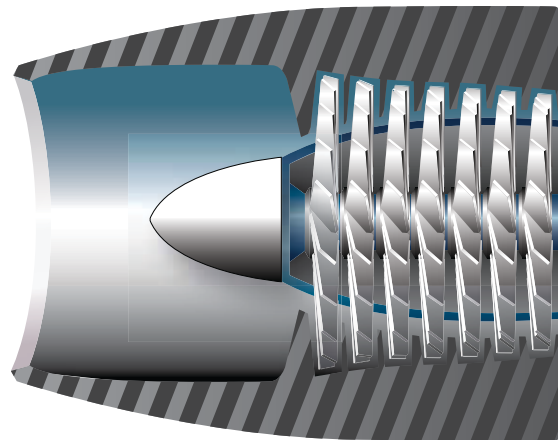

Figure 3-4. An inlet duct acts as a diffuser to decrease the airflow velocity and to increase the static pressure of air.

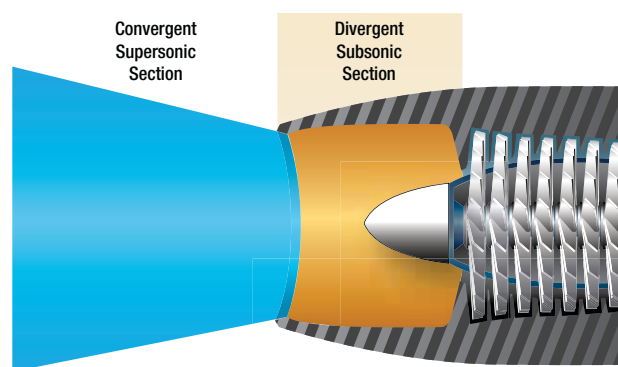

Figure 3-5. The aft section of an inlet duct acting as a subsonic diffuser.

obstruction which automatically protrudes into the duct at high flight Mach numbers. The shock wave results in diffusion of the airflow, which, in turn, decreases the velocity of the airflow. In at least one aircraft installation, both the shock method and the variable-geometry method of causing diffusion are used in combination. The same device that changes the area of the duct also sets up a shock wave that further reduces the speed of the incoming air within the duct. The amount of change in duct area and the magnitude of the shock are varied automatically with the airspeed of the aircraft.

## COMPRESSOR INLET SCREENS

To prevent the engine from readily ingesting any items that can be drawn in the intake, a compressor inlet screen is sometimes placed across the engine air inlet at some location along the inlet duct. Engines that incorporate inlet screens, such as turboprops (*Figure 3-6*) and APUs (*Figure 3-7*) are not as vulnerable to FOD.

The advantages and disadvantages of a screen vary. If the engine is readily subjected to internal damage, as would be the case for an engine having an axial compressor fitted with aluminum compressor blades, an inlet screen is almost a necessity.

Screens, however, add appreciably to inlet duct pressure loss and are very susceptible to icing. Failure due to fatigue is also a problem. A failed screen can sometimes cause more damage than no screen at all. In some instances, inlet screens are made retractable and may be withdrawn from the airstream after takeoff or whenever icing conditions prevail. Such screens are subject to mechanical failure and add both weight and bulk to the installation. In large turbofan engines having steel or titanium compressor (fan) blades, which do not damage easily, the disadvantages of compressor screens outweigh the advantages, so they are not generally used.

## BELLMOUTH COMPRESSOR INLETS

A bellmouth inlet is usually installed on an engine undergoing testing in a test cell. (*Figure 3-8*) It is generally equipped with probes that, with the use of instruments, can measure intake temperature and pressure (total and static). (*Figure 3-9*)

During testing, it is important that the outside static air is allowed to flow into the engine with as little resistance as possible. The bellmouth is attached to the movable part of the test stand and moves with the engine. The thrust stand is made up of two components, one nonmoving and one moving. This is so the moving component can push against a load cell and measure thrust during the testing of the engine. The bellmouth is designed with the single objective of obtaining very high aerodynamic efficiency. Essentially, the inlet is a bell-shaped funnel having carefully rounded shoulders which



Figure 3-6. Example of a turboprop engine that incorporates inlet screens.



Figure 3-8. A bellmouth inlet used during system tests.

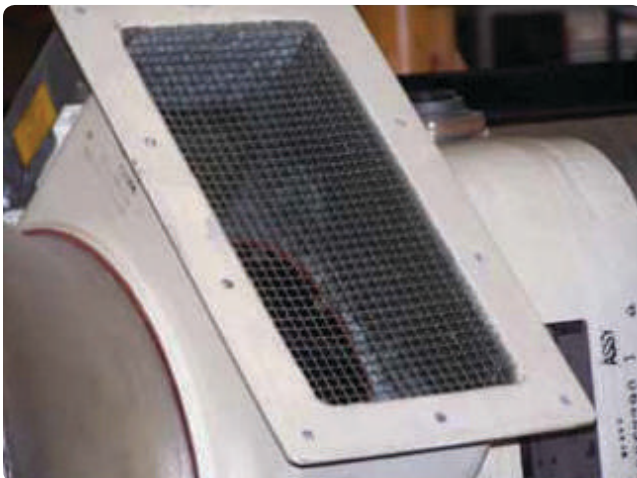

Figure 3-7. An example of an inlet screen on an APU.



Figure 3-9. Probes within a bellmouth inlet used to measure intake temperature and pressure.



offer practically no air resistance. Duct loss is so slight that it is considered zero. The engine can, therefore, be operated without the complications resulting from losses common to an installed aircraft inlet duct. Engine performance data, such as rated thrust and thrust

specific fuel consumption, are obtained while using a bellmouth inlet. Usually, the inlets are fitted with protective screening. In this case, the efficiency lost as the air passes through the screen must be taken into account when very accurate engine data are necessary.

## TURBOPROP AND TURBOSHAFT COMPRESSOR INLETS

The air inlet on a turboprop is more of a problem than some other gas turbine engines because the propeller drive shaft, the hub, and the spinner must be considered in addition to other inlet design factors. The ducted arrangement is generally considered the best inlet design of the turboprop engine as far as airflow and aerodynamic characteristics are concerned. (Figure 3-10) The inlet for many types of turboprops are anti-iced by using electrical elements in the lip opening of the intake. Ducting either part of the engine or nacelle directs the airflow to the intake of the engine. Deflector doors are sometimes used to deflect ice or dirt away from the intake. (Figure 3-11) The air then passes through a screen and into the engine on some models. A conical spinner, which does not allow ice to build up on the surface, is sometimes used with turboprop and turboprop engines. In either event, the arrangement of the spinner and the inlet duct plays an important function in the operation and performance of the engine.

### TURBOFAN ENGINE INLET SECTIONS

High-bypass turbofan engines are usually constructed with the fan at the forward end of the compressor. A typical turbofan intake section is shown in Figure 3-12. Sometimes, the inlet cowl is bolted to the front of the

engine and provides the airflow path into the engine. In dual compressor (dual spool) engines, the fan is integral with the relatively slow turning, low pressure compressor, which allows the fan blades to rotate at low tip speed for best fan efficiency. The fan permits the use of a conventional air inlet duct, resulting in low inlet duct loss. The fan reduces engine damage from ingested foreign material because much of any material that may be ingested is thrown radially outward and passes through the fan discharge rather than through the core of the engine. Warm bleed air is drawn from the engine and circulated on the inside of the inlet lip for anti-icing. The fan hub or spinner is either heated by warm air or is conical as mentioned earlier. Inside the inlet by the fan blade tips is an abradable rub strip that allows the fan blades to rub for short times due to flightpath changes. (Figure 3-13) Also, inside the inlet are sound-reducing materials to lower the noise generated by the fan.

The fan on high-bypass engines consists of one stage of rotating blades and stationary vanes that can range in diameter from less than 84 inches to more than 112 inches. (Figure 3-14) The fan blades are either hollow titanium or composite materials. The air accelerated by the outer part of the fan blades forms a secondary



Figure 3-10. An example of a ducted arrangement on a turboprop engine.



Figure 3-11. Deflector doors used to deflect ice or dirt away from the intake.



Figure 3-12. A typical turbofan intake section.



Figure 3-13. Rubber stripping inside a turbofan engine inlet allows for friction for short periods of time during changes in the flightpath.

airstream, which is ducted overboard without passing through the main engine. This secondary air (fan flow) produces 80 percent of the thrust in high-bypass engines. The air that passes through the inner part of the fan blades becomes the primary airstream (core flow) through the engine itself. (*Figure 3-14*)

The air from the fan exhaust, which is ducted overboard, may be discharged in either of two ways:

1. To the outside air through short ducts (dual exhaust nozzles) directly behind the fan. (*Figure 3-15*)
2. Ducted fan, which uses closed ducts all the way to the rear of the engine, where it is exhausted to the outside air through a mixed exhaust nozzle. This type engine is called a ducted fan and the core airflow and fan airflow mix in a common exhaust nozzle.



Figure 3-14. The air that passes through the inner part of the fan blades becomes the primary airstream.



Figure 3-15. Air from the fan exhaust can be discharged overboard through short ducts directly behind the fan.



**Question: 3-1**

The amount of air passing through a turbine engine is dependent upon what three factors?

**Question: 3-5**

How is anti-icing achieved on most turbofan engine inlets?

**Question: 3-2**

The function of an inlet guide vane is to \_\_\_\_\_.

**Question: 3-6**

If the aft section of an inlet duct increases in size, What happens to the air velocity as it approaches the compressor.

**Question: 3-3**

A bellmouth inlet is used for \_\_\_\_\_.

**Question: 3-7**

Name three, disadvantages to an inlet screen.

**Question: 3-4**

What is the primary purpose of a turbine engine inlet assembly?

**Question: 3-8**

What is the cause of compressor stall?

## ANSWERS

*Answer: 3-1*

The compressor speed (rpm).

The forward speed of the aircraft.

The density of the ambient (surrounding) air.

*Answer: 3-5*

Warm air is bled through ducts in the inlet from the compressor.

*Answer: 3-2*

straighten the inlet airflow and direct it into the first stages of the compressor.

*Answer: 3-6*

Incoming air velocity slows down. This is particularly important on supersonic aircraft.

*Answer: 3-3*

testing.

*Answer: 3-7*

Reduces inlet pressure, susceptible to icing, can fail and be ingested by the engine.

*Answer: 3-4*

Minimize turbulence in air entering the compressor.

*Answer: 3-8*

Turbulent air in the engine inlet.



PART-66 SYLLABUS LEVELS  
 CERTIFICATION CATEGORY → A1 B1

**Sub-Module 04**  
**COMPRESSORS**

Knowledge Requirements

*15.4 - Compressors*

- Axial and centrifugal types;
- Constructional features and operating principles and applications;
- Fan balancing;
- Operation:
- Causes and effects of compressor stall and surge;
- Methods of air flow control: bleed valves, variable inlet guide vanes, variable stator vanes, rotating stator blades;
- Compressor ratio.

A1	B1
1	2

COMPRESSORS

**Level 1**

A familiarization with the principal elements of the subject.

*Objectives:*

- (a) The applicant should be familiar with the basic elements of the subject.
- (b) The applicant should be able to give a simple description of the whole subject, using common words and examples.
- (c) The applicant should be able to use typical terms.

**Level 2**

A general knowledge of the theoretical and practical aspects of the subject and an ability to apply that knowledge.

*Objectives:*

- (a) The applicant should be able to understand the theoretical fundamentals of the subject.
- (b) The applicant should be able to give a general description of the subject using, as appropriate, typical examples.
- (c) The applicant should be able to use mathematical formula in conjunction with physical laws describing the subject.
- (d) The applicant should be able to read and understand sketches, drawings and schematics describing the subject.
- (e) The applicant should be able to apply his knowledge in a practical manner using detailed procedures.

## COMPRESSOR SECTION

The compressor section of the gas turbine engine performs critical functions. Its primary function is to supply air in sufficient quantity to satisfy the requirements of the combustion burners. Specifically, to fulfill its purpose, the compressor must increase the pressure of the mass of air received from the air inlet duct, and then, discharge it to the burners in the quantity and at the pressures required.

A secondary function of the compressor is to supply air for various purposes in the engine and aircraft. This bleed-air is taken from any of the various pressure stages of the compressor. The exact location of the bleed ports is dependent on the pressure or temperature required for a particular job. The ports are small openings in the compressor case adjacent to the particular stage from which the air is to be bled. Varying degrees of pressure are available by tapping into the appropriate stage. Air is often bled from the final or highest pressure stage since, at this point, pressure and air temperature are at a maximum. At times it may be necessary to cool this high-pressure air. If it is used for cabin pressurization or other purposes to which excess heat would be uncomfortable or detrimental, the air is sent through an air conditioning unit before it enters the cabin.

Bleed air is often controlled through the use of a bleed valve. This can be mounted directly to the compressor case or in the downstream ducting. Automatic and manual control of bleed valves is possible with the primary function being to open and close the valve for passage of the bleed air into the pneumatic system.

Bleed air is utilized in a wide variety of ways. Some of the current applications of bleed air are:

1. Cabin pressurization, heating, and cooling;
2. Deicing and anti-icing equipment;
3. Pneumatic starting of engines;
4. Auxiliary drive units (ADU).

## COMPRESSOR TYPES AND APPLICATIONS

The two principal types of compressors currently being used in gas turbine aircraft engines are centrifugal flow and axial flow. The centrifugal-flow compressor achieves its purpose by picking up the entering air and accelerating it outwardly by centrifugal action. The axial-flow compressor compresses air while the air continues in its original direction of flow, thus avoiding the energy loss caused by turns. The components of each of these two types of compressor have their individual functions in the compression of air for the combustion section. A stage in a compressor is considered to be a rise in pressure.

Axial flow compressors are normally found on turbofan engines which are widely used in aviation. Centrifugal flow compressors are commonly used in turbo prop and turboshaft engines.

## CENTRIFUGAL-FLOW COMPRESSORS

The centrifugal-flow compressor consists of an impeller (rotor), a diffuser (stator), and a compressor manifold. (Figure 4-1)

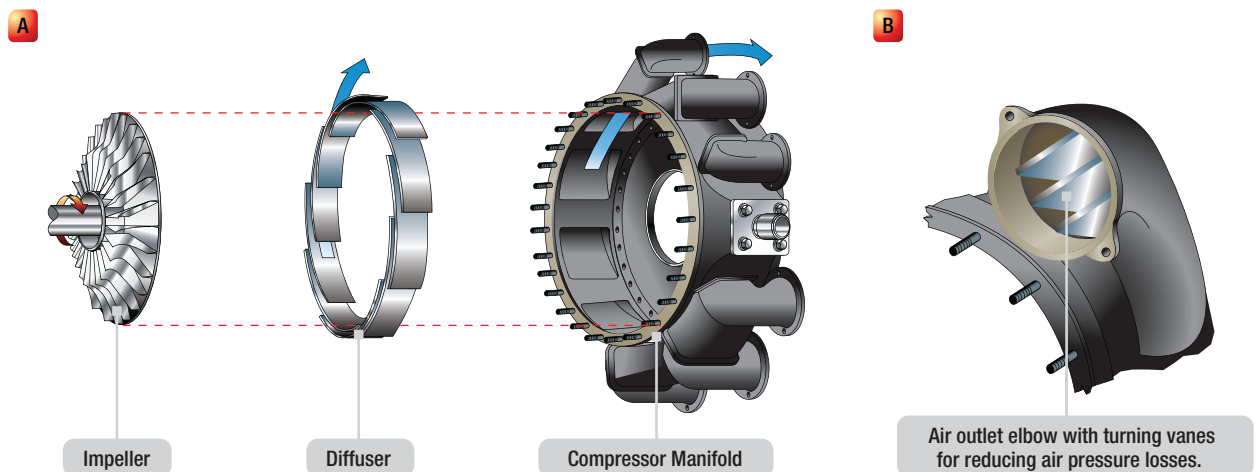

Figure 4-1. (A) Components of a centrifugal-flow compressor; (B) Air outlet elbow with turning vanes for reducing air pressure losses.

Centrifugal compressors have a high pressure rise per stage that can be around 8:1. Generally centrifugal compressors are limited to two stages due to efficiency concerns. The two main functional elements are the impeller and the diffuser. Although the diffuser is a separate unit and is placed inside and bolted to the manifold, the entire assembly (diffuser and manifold) is often referred to as the diffuser. For clarification during compressor familiarization, the units are treated individually. The impeller is usually made from forged aluminum alloy, heat treated, machined, and smoothed for minimum flow restriction and turbulence.

In most types, the impeller is fabricated from a single forging. This type impeller is shown in *Figure 4-1*. The impeller, whose function is to pick up and accelerate the air outwardly to the diffuser, may be either of two types—single entry or double entry. The principal differences between the two types of impellers are size and ducting arrangement. The double-entry type has a smaller diameter, but is usually operated at a higher rotational speed to assure sufficient airflow. The single-entry impeller, shown in *Figure 4-2*, permits convenient ducting directly to the impeller eye (inducer vanes) as opposed to the more complicated ducting necessary to reach the rear side of the double-entry type. Although slightly more efficient in receiving air, the single entry impeller must be large in diameter to deliver the same quantity of air as the double-entry type. This, of course, increases the overall diameter of the engine.

Included in the ducting for double-entry compressor engines is the plenum chamber. This chamber is necessary for a double-entry compressor because the air must enter



Figure 4-2. Single-entry impeller.

the engine at almost right angles to the engine axis. Therefore, in order to give a positive flow, the air must surround the engine compressor at a positive pressure before entering the compressor. Included in some installations as necessary parts of the plenum chamber are the auxiliary air-intake doors (blow-in doors). These blow-in doors admit air to the engine compartment during ground operation, when air requirements for the engine are in excess of the airflow through the inlet ducts. The doors are held closed by spring action when the engine is not operating. During operation, however, the doors open automatically whenever engine compartment pressure drops below atmospheric pressure. During takeoff and flight, ram air pressure in the engine compartment aids the springs in holding the doors closed.

The diffuser is an annular chamber provided with a number of vanes forming a series of divergent passages into the manifold. The diffuser vanes direct the flow of air from the impeller to the manifold at an angle designed to retain the maximum amount of energy imparted by the impeller. They also deliver the air to the manifold at a velocity and pressure satisfactory for use in the combustion chambers. Refer to *Figure 4-1A* and note the arrow indicating the path of airflow through the diffuser, then through the manifold.

The compressor manifold shown in *Figure 4-1A* diverts the flow of air from the diffuser, which is an integral part of the manifold, into the combustion chambers. The manifold has one outlet port for each chamber so that the air is evenly divided. A compressor outlet elbow is bolted to each of the outlet ports. These air outlets are constructed in the form of ducts and are known by a variety of names, such as air outlet ducts, outlet elbows, or combustion chamber inlet ducts. Regardless of the terminology used, these outlet ducts perform a very important part of the diffusion process; that is, they change the radial direction of the airflow to an axial direction, in which the diffusion process is completed after the turn. To help the elbows perform this function in an efficient manner, turning vanes (cascade vanes) are sometimes fitted inside the elbows. These vanes reduce air pressure losses by presenting a smooth, turning surface. (*Figure 4-1B*)



## AXIAL-FLOW COMPRESSOR

The axial-flow compressor has two main elements: a rotor and a stator. The rotor has blades fixed on a spindle. These blades impel air rearward in the same manner as a propeller because of their angle and airfoil contour. The rotor, turning at high speed, takes in air at the compressor inlet and impels it through a series of stages. From inlet to exit, the air flows along an axial path and is compressed at a ratio of approximately 1.25:1 per stage. The action of the rotor increases the compression of the air at each stage and accelerates it rearward through several stages. With this increased velocity, energy is transferred from the compressor to the air in the form of velocity energy. The stator blades act as diffusers at each stage, partially converting high velocity to pressure. Each consecutive pair of rotor and stator blades constitutes a pressure stage. The number of rows of blades (stages) is determined by the amount of air and total pressure rise required. Compressor pressure ratio increases with the number of compression stages. Most engines utilize up to 16 stages and more.

The stator has rows of vanes, which are in turn attached inside an enclosing case. The stator vanes, which are stationary, project radially toward the rotor axis and fit closely on either side of each stage of the rotor blades. In some cases, the compressor case, into which the stator vanes are fitted, is horizontally divided into halves. Either the upper or lower half may be removed for inspection or maintenance of rotor and stator blades.

The function of the stator vanes is to receive air from the air inlet duct or from each preceding stage and increase the pressure of the air and deliver it to the next stage at the correct velocity and pressure. They also control the direction of air to each rotor stage to obtain the maximum possible compressor blade efficiency. Shown in *Figure 4-3* are the rotor and stator elements of a typical axial-flow compressor. The first stage rotor blades can be preceded by an inlet guide vane assembly that can be fixed or variable.

The guide vanes direct the airflow into the first stage rotor blades at the proper angle and impart a swirling motion to the air entering the compressor. This pre-swirl, in the direction of engine rotation, improves the aerodynamic characteristics of the compressor by reducing drag on the first stage rotor blades. The inlet guide vanes are curved steel vanes usually welded to steel inner and outer shrouds.

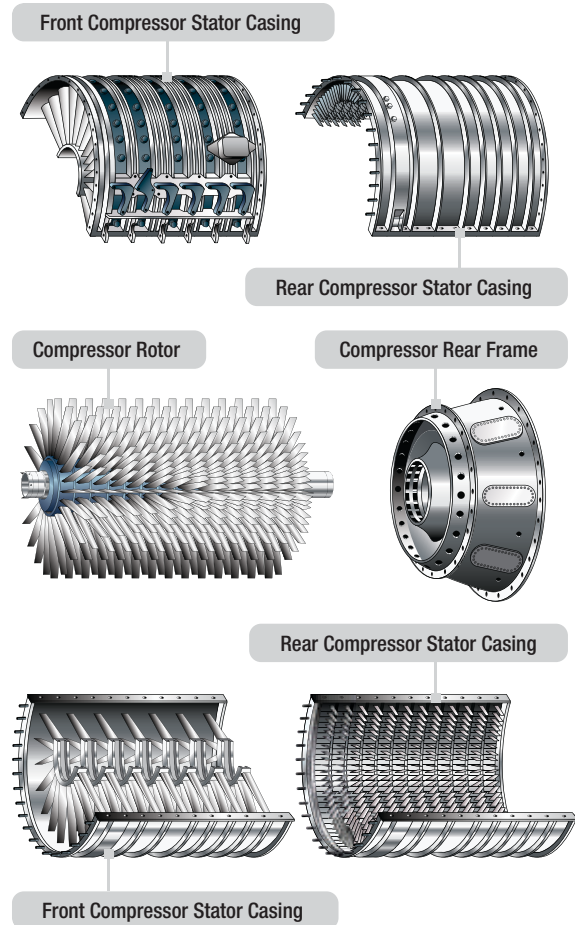

Figure 4-3. Rotor and stator elements of a typical axial-flow compressor.

At the discharge end of the compressor, the stator vanes are constructed to straighten the airflow to eliminate turbulence. These vanes are called straightening vanes or the outlet vane assembly. The casings of axial-flow compressors not only support the stator vanes and provide the outer wall of the axial path the air follows, but they also provide the means for extracting compressor air for various purposes. The stator vanes are usually made of steel with corrosion- and erosion-resistant qualities. Quite frequently, they are shrouded (enclosed) by a band of suitable material to simplify the fastening problem. The vanes are welded into the shrouds, and the outer shroud is secured to the compressor housing inner wall by radial retaining screws.

The rotor blades are usually made of stainless steel with the latter stages being made of titanium. The design of blade attachment to the rotor disk rims varies, but they are commonly fitted into disks by either bulb-type or fir-tree methods. (*Figure 4-4*) The blades are then locked into place by differing methods. Compressor blade tips are reduced in thickness by cutouts, referred

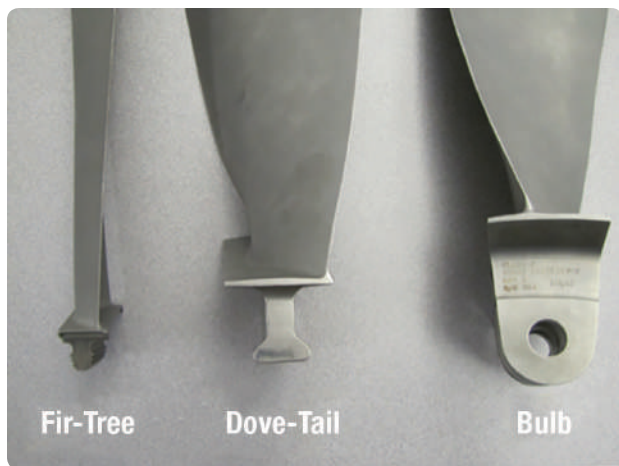

Figure 4-4. Common designs of compressor blade attachment to the rotor disk.

to as blade profiles. These profiles prevent serious damage to the blade or housing should the blades contact the compressor housing. This condition can occur if rotor blades become excessively loose or if rotor support is reduced by a malfunctioning bearing. Even though blade profiles greatly reduce such possibilities, occasionally a blade may break under stress of rubbing and cause considerable damage to compressor blades and stator vane assemblies. The blades vary in length from entry to discharge because the annular working space (drum to casing) is reduced progressively toward the rear by the decrease in the casing diameter. (Figure 4-5) This feature provides for a fairly constant velocity through the compressor, which helps to keep the flow of air constant.

The rotor features either drum-type or disk-type construction. The drum-type rotor consists of rings that are flanged to fit one against the other, wherein the entire assembly can then be held together by through bolts. This type of construction is satisfactory for low-speed compressors where centrifugal stresses are low. The disk-type rotor consists of a series of disks machined from aluminum forgings, shrunk over a steel shaft, with rotor blades dovetailed into the disk rims. Another method of rotor construction is to machine the disks and shaft from a single aluminum forging, and then to bolt steel stub shafts on the front and rear of the assembly to provide bearing support surfaces and splines for joining the turbine shaft.

The drum-type and disk-type rotors are illustrated in Figures 4-5 and 4-6, respectively.

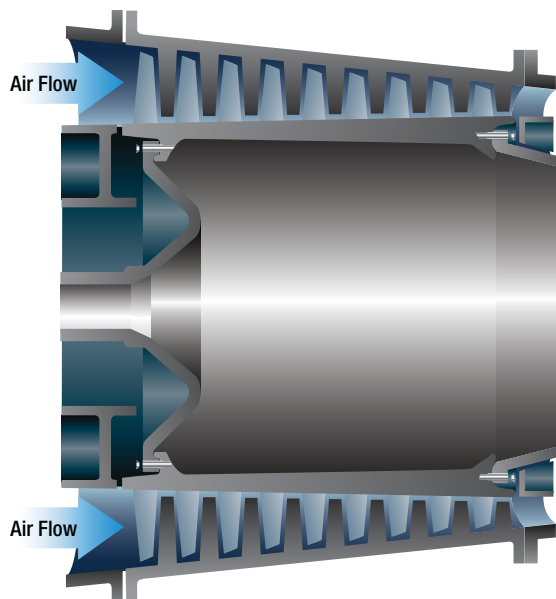

Figure 4-5. Drum-type compressor rotor.

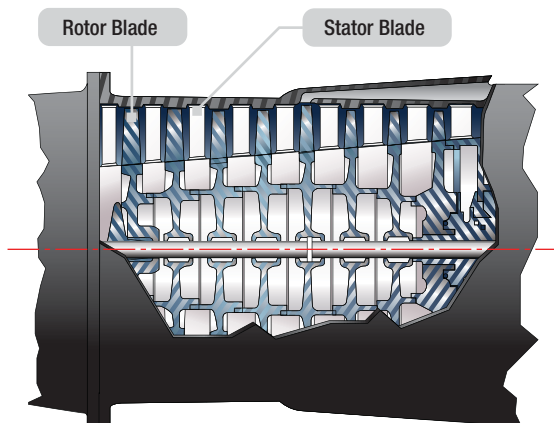

Figure 4-6. Disk-type compressor rotor.

The combination of the compressor stages and turbine stages on a common shaft is an engine referred to as an engine spool. The common shaft is provided by joining the turbine and compressor shafts by a suitable method. The engine's spool is supported by bearings, which are seated in suitable bearing housings.

As mentioned earlier, there are two configurations of the axial compressor currently in use: the single rotor/spool and the dual rotor/spool, sometimes referred to as solid spool and split spool (two spool, dual spool). One version of the solid-spool (one spool) compressor uses variable inlet guide vanes. Also, the first few rows of stator vanes are variable. The main difference between variable inlet guide vane (VIGV) and a variable stator vane (VSV) is their position with regard to the rotor blades. VIGV are in front of the rotor blades, and

VSV are behind the rotor blades. The angles of the inlet guide vanes and the first several stages of the stator vanes can be variable. During operation, air enters the front of the engine and is directed into the compressor at the proper angle by the variable inlet guide and directed by the VSV. The air is compressed and forced into the combustion section. A fuel nozzle that extends into each combustion liner atomizes the fuel for combustion. These variables are controlled in direct relation to the amount of power the engine is required to produce by the power lever position.

Most turbofan engines are of the split-spool compressor type. Most large turbofan engines use a large fan with a few stages of compression called the low-pressure spool. These turbofans incorporate two compressors with their respective turbines and interconnecting shafts, which form two physically independent rotor systems. Many dual rotor systems have rotors turning in opposite directions and with no mechanical connection to each other. The second spool, referred to as the high-pressure spool and is the compressor for the gas generator and core of the engine, supplies air to the combustion section of the engine. The advantages and disadvantages of both types of compressors are included in the following list. Even though each type has advantages and disadvantages, each has its use by type and size of engine.

The centrifugal flow compressor's advantages are:

- High pressure rise per stage,
- Efficiency over wide rotational speed range,
- Simplicity of manufacture and low cost,
- Low weight, and
- Low starting power requirements.

The centrifugal flow compressor's disadvantages are:

- Its large frontal area for a given airflow and
- Losses in turns between stages.

The axial flow compressor's advantages are:

- High peak efficiencies;
- Small frontal area for given airflow;
- Straight-through flow, allowing high ram efficiency; and
- Increased pressure rise by increasing number of stages, with negligible losses.

The axial flow compressor's disadvantages are:

- Good efficiencies over only narrow rotational speed range,
- Difficulty of manufacture and high cost,
- Relatively high weight, and
- High starting power requirements (partially overcome by split compressors).

---

## DIFFUSER

The diffuser is the divergent section of the engine after the compressor and before the combustion section. It has the all-important function of reducing high-velocity compressor discharge air to increased pressure at a slower velocity. This prepares the air for entry into

the flame burning area of the combustion section at a lower velocity so that the flame of combustion can burn continuously. If the air passed through the flame area at a high velocity, it could extinguish the flame.

---

## FAN BALANCE

All turbine engine rotating assemblies require balancing by the manufacturer, however only fan blades can be balanced without disassembly of the engine. High bypass fans require particular attention to balance while in service due to their large diameter and high rotational forces. Even minor damage can cause the fan to become unbalanced and compromise the integrity of the rotating assembly and its bearings.

Fan blades are assembled and balanced as a set using computer software which considers the radial moment weight of each individual blade. The radial moment weight is usually marked on the blade case or on the bottom of the dovetails for blade attachment on a General Electric CF6 turbofan engine.

The blades are fitted and a vibration survey is carried out. If necessary trim balance weights will be fitted to reduce the vibration. Trim balance weights may be

either oversize bolts securing the fan spinner, special trim balance bolts fitted at right angles to the spinner securing bolts, or special balance weights that fit on the fan balance ring below the blade root.

If a fan blade is damaged in the field and replacement is needed, there are three trim balance options. The blade can be replaced with a blade that is within a small tolerance of the original radial moment weight so the balance of the whole assembly is not affected. The blade could also be replaced with another of different weight then, using a formula from the maintenance manual, a correcting weight could be fitted to maintain assembly balance. The third option is to replace the blade and the blade that is diametrically opposite to the damaged blade with a pair of blades that are of matching weights.

After some considerable time in service the vibration level of the N1 spool can gradually increase. When not due to blade damage or movement, the dry film lubricant on the blade roots could be worn. In this instance the fan blades should be removed, the roots cleaned and the dry film lubricant replaced in accordance with the manufacturer's instructions.

Out of balance forces are indicated by their magnitude and direction. The direction is given in the form of a phase angle from a known datum, usually the number 1 balance hole. The magnitude is in the form of 'aircraft units'. Fan assembly balance information may be displayed on either EICAS or ECAM system displays on the flight deck or on special balancing test equipment. Limits are specified in the maintenance manual.

---

## COMPRESSOR STALL AND SURGE

Each compressor blade is an airfoil. It is subject to the same aerodynamic principles of a wing or a propeller. Just as a wing can stall and lose lift when the maximum angle of attack is exceeded, the same is true for a compressor blade or, the entire stage or stages of the compressor. When a single compressor blade or stage stalls, it is said to have stalled. When the entire compressor stalls, it is known as surge.

Compressors experience stall or surge on the ground when a high wind suddenly blows across the engine inlet duct. The same can happen in flight. The distortion of the inlet airflow can be such that the angle of the air striking the compressor blades causes the stall or surge. At other times in flight, icing, a rapid throttle movement, rapid maneuver, or a fuel governor malfunction may cause a stall or surge. Any deterioration of blade shape due to erosion, build-up of deposits or blade damage contributes to the problem. Airflow control systems must function as designed to provide the compressor with a steady flow of air at the designed angle so the compressor can function properly. Failure of the variable inlet guide vanes, variable stator vanes, or even a compressor bleed system malfunction can all contribute to a stall or surge.

The technician may recognize a compressor stall or surge during a ground run-up by hearing abnormal noises, rumbling or moaning or just a bang. This accompanied by rapid changes in values indicated for RPM, EGT,

and EPR are signs of compressor stall or surge. Poor throttle response is another sign.

The effects of stall or surge are detrimental to the engine and, moreover to engine life. Changes in material properties and fatigue due to shock loading of internal engine components occur. High EGT spikes during a surge reflect high turbine section temperatures that may exceed design capabilities. The result is a reduction in engine life.



*Question: 4-1*

The purpose of the compressor is to increase the \_\_\_\_\_ of the mass of air received from the air inlet duct, and then, discharge it to the burner section.

*Question: 4-5*

A \_\_\_\_\_ is recognized during a ground run-up by hearing abnormal noises, rumbling or moaning or just a bang.

*Question: 4-2*

Centrifugal flow compressors are commonly used in \_\_\_\_\_ and turboshaft engines.

*Question: 4-6*

What is meant by a 12 stage compressor?

*Question: 4-3*

Name 3 advantages of an axial flow compressor.

*Question: 4-7*

What is the purpose of the diffuser of a compressor section?

*Question: 4-4*

What is the divergent section of a gas turbine engine that reduces the high-velocity compressor discharge for the combustion section called?

*Question: 4-8*

A centrifugal flow compressor creates a \_\_\_\_\_ pressure rise per stage, but contains \_\_\_\_\_ total stages than an axial type compressor.

## ANSWERS

*Answer:* 4-1  
pressure.

*Answer:* 4-5  
compressor stall or surge.

*Answer:* 4-2  
turboprop.

*Answer:* 4-6  
There are twelve distinct areas of pressure rises within the compressor section.

*Answer:* 4-3  
High peak efficiencies.  
Small frontal area for given airflow.  
Straight-through flow allows high ram efficiency.  
Increased pressure rise by increasing number of stages with negligible losses.

*Answer:* 4-7  
Slows the velocity of the air as it enters the combustion section.

*Answer:* 4-4  
A diffuser.

*Answer:* 4-8  
higher; fewer



PART-66 SYLLABUS **LEVELS**  
 CERTIFICATION CATEGORY → **A1** **B1**

**Sub-Module 05**  
**COMBUSTION SECTION**

Knowledge Requirements

*15.5 - Combustion Section*

Constructional features and principles of operation.

CERTIFICATION CATEGORY →	A1	B1
	1	2

COMBUSTION SECTION

**Level 1**

A familiarization with the principal elements of the subject.

*Objectives:*

- (a) The applicant should be familiar with the basic elements of the subject.
- (b) The applicant should be able to give a simple description of the whole subject, using common words and examples.
- (c) The applicant should be able to use typical terms.

**Level 2**

A general knowledge of the theoretical and practical aspects of the subject and an ability to apply that knowledge.

*Objectives:*

- (a) The applicant should be able to understand the theoretical fundamentals of the subject.
- (b) The applicant should be able to give a general description of the subject using, as appropriate, typical examples.
- (c) The applicant should be able to use mathematical formula in conjunction with physical laws describing the subject.
- (d) The applicant should be able to read and understand sketches, drawings and schematics describing the subject.
- (e) The applicant should be able to apply his knowledge in a practical manner using detailed procedures.



## COMBUSTION SECTION

The combustion section houses the combustion process, which raises the temperature of the air passing through the engine. This process releases energy contained in the air/fuel mixture. The major part of this energy is required at the turbine or turbine stages to drive the compressor. About  $\frac{2}{3}$  of the energy is used to drive the gas generator compressor. The remaining energy passes through the remaining turbine stages that absorb more of the energy to drive the fan, output shaft, or propeller. Only the pure turbojet allows the air to create all the thrust or propulsion by exiting the rear of the engine in the form of a high-velocity jet. These other engine types have some jet velocity out the rear of the engine but most of the thrust or power is generated by the additional turbine stages driving a large fan, propeller, or helicopter rotor blades.

The primary function of the combustion section is, of course, to burn the fuel/air mixture, thereby adding heat energy to the air. To do this efficiently, the combustion chamber must:

- Provide the means for proper mixing of the fuel and air to assure good combustion,
- Burn this mixture efficiently,
- Cool the hot combustion products to a temperature that the turbine inlet guide vanes/blades can withstand under operating conditions, and
- Deliver the hot gases to the turbine section.

The location of the combustion section is directly between the compressor and the turbine sections. The combustion chambers are always arranged coaxially with the compressor and turbine regardless of type, since the chambers must be in a through flow position to function efficiently. All combustion chambers contain the same basic elements:

1. Casing
2. Perforated inner liner
3. Fuel injection system
4. Some means for initial ignition
5. Fuel drainage system to drain off unburned fuel after engine shutdown.

There are currently three basic types of combustion chambers, variations within type being in detail only.

These types are:

1. Can type
2. Can-annular type
3. Annular type

The can-type combustion chamber is typical of the type used on turboshaft and APUs. (*Figure 5-1*) Each of the can-type combustion chambers consists of an outer case or housing, within which there is a perforated stainless steel (highly heat resistant) combustion chamber liner or inner liner. (*Figure 5-2*) The outer case is removed to facilitate liner replacement.

Older engines with several combustion cans had each can with inter-connector (flame propagation) tube, which was a necessary part of the can-type combustion



Figure 5-1. Can-type combustion chamber.



Figure 5-2. Inside view of a combustion chamber liner.

chambers. Since each can be a separate burner operating independently of the other cans, there must be some way to spread combustion during the initial starting operation. This is accomplished by interconnecting all the chambers. As the flame is started by the spark igniter plugs in two of the lower chambers, it passes through the tubes and ignites the combustible mixture in the adjacent chamber, and continues until all the chambers are burning.

The flame tubes vary in construction details from one engine to another, although the basic components are almost identical. (*Figure 5-3*) The spark igniters previously mentioned are normally two in number, and are located in two of the can-type combustion chambers.

Another very important requirement in the construction of combustion chambers is providing the means for draining unburned fuel. This drainage prevents gum deposits in the fuel manifold, nozzles, and combustion chambers. These deposits are caused by the residue left when the fuel evaporates.

Probably most important is the danger of after fire if the fuel is allowed to accumulate after shutdown. If the fuel is not drained, a great possibility exists that, at the next starting attempt, the excess fuel in the combustion chamber will ignite and exhaust gas temperature will exceed safe operating limits.

The liners of the can-type combustors have perforations of various sizes and shapes, each hole having a specific purpose and effect on flame propagation within the liner. (*Figure 5-1*) The air entering the combustion chamber is divided by the proper holes, louvers, and slots

into two main streams—primary and secondary air. The primary or combustion air is directed inside the liner at the front end, where it mixes with the fuel and is burned. Secondary or cooling air passes between the outer casing and the liner and joins the combustion gases through larger holes toward the rear of the liner, cooling the combustion gases from about 3 500 °F to near 1 500 °F.

To aid in atomization of the fuel, holes are provided around the fuel nozzle in the dome or inlet end of the can-type combustor liner. Louvers are also provided along the axial length of the liners to direct a cooling layer of air along the inside wall of the liner. This layer of air also tends to control the flame pattern by keeping it centered in the liner, thereby preventing burning of the liner walls. *Figure 5-4* illustrates the flow of air through the louvers in the annular combustion chamber.

Some provision is always made in the combustion chamber case for installation of a fuel nozzle. The fuel nozzle delivers the fuel into the liner in a finely atomized spray. The more the spray is atomized, the more rapid and efficient the burning process is. Two types of fuel nozzle currently being used in the various types of combustion chambers are the simplex nozzle and the duplex nozzle.

The spark igniter plugs of the can-annular combustion chamber are the same basic type used in the can-type combustion chambers, although construction details may vary. There are usually two igniters mounted on the boss provided on each of the chamber housings. The igniters must be long enough to protrude from the housing into the combustion chamber.

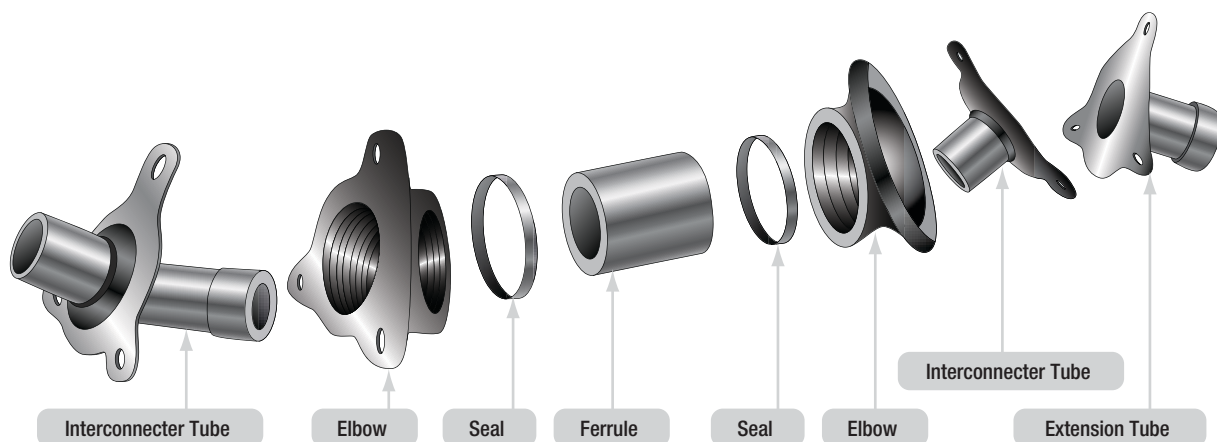

Figure 5-3. Interconnecting flame tubes for can-type combustion chambers.



Figure 5-4. Annular combustion chamber liner.

The burners are interconnected by projecting flame tubes which facilitate the engine-starting process as mentioned previously in the can-type combustion chamber familiarization. The flame tubes function identically to those previously discussed, differing only in construction details.

This type of combustion chamber is not used in modern engines. The forward face of each chamber presents six apertures, which align with the six fuel nozzles of the corresponding fuel nozzle cluster. (*Figure 5-5*) These nozzles are the dual-orifice (duplex) type requiring the use of a flow-divider (pressurizing valve), as mentioned in the can-type combustion chamber discussion. Around each nozzle are pre-swirl vanes for imparting a swirling motion to the fuel spray, which results in better atomization of the fuel, better burning, and efficiency.

The swirl vanes function to provide two effects imperative to proper flame propagation:

1. High flame speed—better mixing of air and fuel, ensuring spontaneous burning.
2. Low air velocity axially—swirling eliminates overly rapid flame movement axially.

The swirl vanes greatly aid flame propagation, since a high degree of turbulence in the early combustion and cooling stages is desirable. The vigorous mechanical mixing of the fuel vapor with the primary air is necessary, since mixing by diffusion alone is too slow. This same mechanical mixing is also established by other means, such as placing coarse screens in the diffuser outlet, as is the case in most axial flow engines.

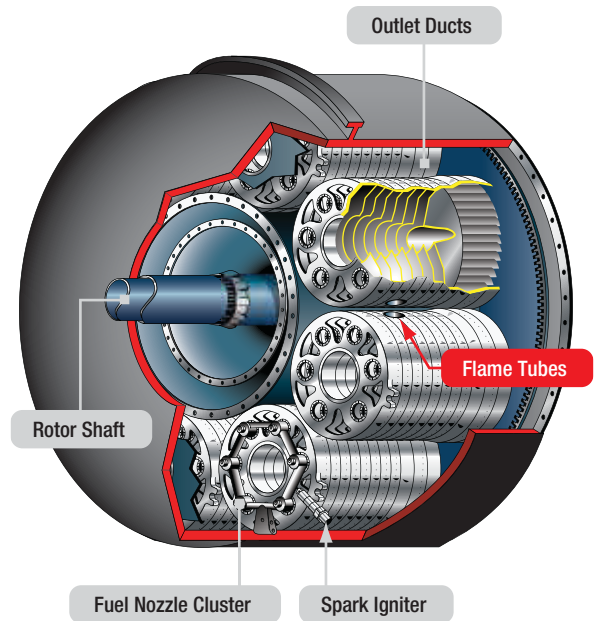

Figure 5-5. Can-annular combustion chamber components and arrangement.

The can-annular combustion chambers also must have the required fuel drain valves located in two or more of the bottom chambers, assuring proper drainage and elimination of residual fuel burning at the next start.

The flow of air through the holes and louvers of the can-annular chambers, is almost identical with the flow through other types of burners. (*Figure 5-5*) Special baffling is used to swirl the combustion airflow and to give it turbulence. *Figure 5-6* shows the flow of combustion air, metal cooling air, and the diluent or gas cooling air. The air flow direction is indicated by the arrows.

The basic components of an annular combustion chamber are a housing and a liner, as in the can type. The liner consists of an undivided circular shroud

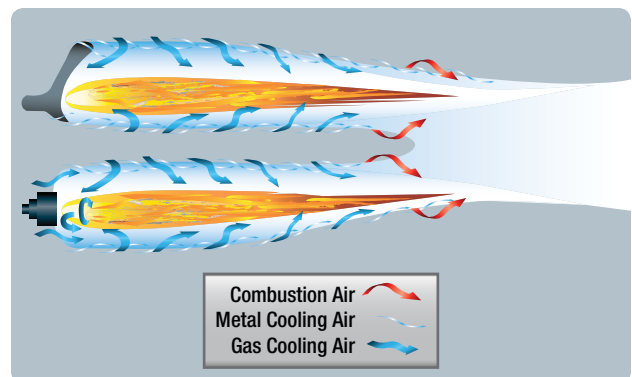

Figure 5-6. Airflow through a can-annular combustion chamber.

extending all the way around the outside of the turbine shaft housing. The chamber may be constructed of heat-resistant materials, which are sometimes coated with thermal barrier materials, such as ceramic materials. The annular combustion chamber is illustrated in *Figure 5-7*.

Modern turbine engines usually have an annular combustion chamber. As can be seen in *Figure 5-8*, the annular combustion chamber also uses louvers and holes to prevent the flame from contacting the side of the combustion chamber.



Figure 5-7. Annular combustion with chamber ceramic coating.

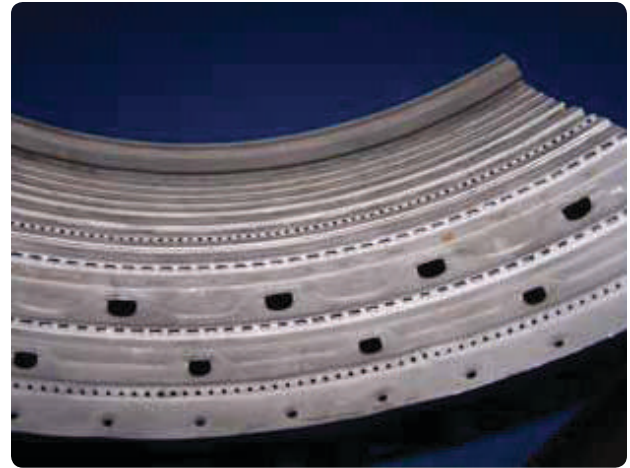

Figure 5-8. Combustion chamber louvers and holes.



**Question: 5-1**

The major part of the energy from combustion in a gas turbine engine is used to drive the \_\_\_\_\_.

**Question: 5-4**

How are unwanted fires prevented from starting in a combustion chamber?

**Question: 5-2**

Modern turbine engines usually have \_\_\_\_\_ combustion chambers.

**Question: 5-5**

What is the purpose of swirl vanes in a combustion chamber?

**Question: 5-3**

What type of combustion chamber is typically found of turboshaft engines, including APUs?

**Question: 5-6**

What is the purpose of secondary airflow within a combustion chamber?

## ANSWERS

*Answer: 5-1*  
compressor.

*Answer: 5-4*  
Drains holes are installed for unburned fuel after shutdown.

*Answer: 5-2*  
annular.

*Answer: 5-5*  
Increases turbulence within the combustion chamber for faster mixing of fuel and air.

*Answer: 5-3*  
Can type.

*Answer: 5-6*  
Cools the primary airflow to an acceptable temperature to enter the turbine section plus helps protect the chamber liners from excess heat.



PART-66 SYLLABUS LEVELS  
 CERTIFICATION CATEGORY → A1 B1

**Sub-Module 06**  
**TURBINE SECTION**  
 Knowledge Requirements

*15.6 - Turbine Section*

- Operation and characteristics of different turbine blade types;
- Blade to disk attachment;
- Nozzle guide vanes;
- Causes and effects of turbine blade stress and creep.

	A1	B1
	2	2

**Level 2**

A general knowledge of the theoretical and practical aspects of the subject and an ability to apply that knowledge.

*Objectives:*

- (a) The applicant should be able to understand the theoretical fundamentals of the subject.
- (b) The applicant should be able to give a general description of the subject using, as appropriate, typical examples.
- (c) The applicant should be able to use mathematical formula in conjunction with physical laws describing the subject.
- (d) The applicant should be able to read and understand sketches, drawings and schematics describing the subject.
- (e) The applicant should be able to apply his knowledge in a practical manner using detailed procedures.

TURBINE SECTION



# TURBINE AREA INSPECTION

## TURBINE SECTION

The turbine transforms a portion of the kinetic (velocity) energy of the exhaust gases into mechanical energy to drive the gas generator compressor and accessories. The sole purpose of the gas generator turbine is to absorb approximately 60 to 70 percent of the total pressure energy from the exhaust gases. The exact amount of energy absorption at the turbine is determined by the load the turbine is driving (i.e., compressor size and type, number of accessories, and the load applied by the other turbine stages). These turbine stages can be used to drive a low-pressure compressor (fan), propeller, and shaft. The turbine section of a gas turbine engine is located aft, or downstream, of the combustion chamber. Specifically, it is directly behind the combustion chamber outlet.

The turbine assembly consists of two basic elements: turbine inlet guide vanes and turbine blades. (*Figures 6-1 and 6-2*) The stator element is known by a variety of names, of which turbine inlet nozzle vanes, turbine inlet guide vanes, and nozzle diaphragm are three of the most commonly used. The turbine inlet nozzle vanes are located directly aft of the combustion chambers and immediately forward of the turbine wheel. This is the highest or hottest temperature that comes in contact with metal components in the engine. The turbine inlet temperature must be controlled or damage will occur to the turbine inlet vanes.

After the combustion chamber has introduced the heat energy into the mass airflow and delivered it evenly to

the turbine inlet nozzles, the nozzles must prepare the mass air flow to drive the turbine rotor. The stationary vanes of the turbine inlet nozzles are contoured and set at such an angle that they form a number of small nozzles discharging gas at extremely high speed; thus, the nozzle converts a varying portion of the heat and pressure energy to velocity energy that can then be converted to mechanical energy through the turbine blades.

The second purpose of the turbine inlet nozzle is to deflect the gases to a specific angle in the direction of turbine wheel rotation. Since the gas flow from the nozzle must enter the turbine blade passageway while it is still rotating, it is essential to aim the gas in the general direction of turbine rotation.

The turbine inlet nozzle assembly consists of an inner shroud and an outer shroud between which the nozzle vanes are fixed. The number and size of inlet vanes employed vary with different types and sizes of engines. *Figure 6-3* illustrates typical turbine inlet nozzles featuring loose and welded vanes. The vanes of the turbine inlet nozzle may be assembled between the outer and inner shrouds or rings in a variety of ways. Although the actual elements may vary slightly in configuration and construction features, there is one characteristic peculiar to all turbine inlet nozzles: the nozzle vanes must be constructed to allow thermal expansion.

Otherwise, there would be severe distortion or warping of the metal components because of rapid temperature changes. The thermal expansion of turbine nozzles is



Figure 6-1. Turbine inlet guide vanes.



Figure 6-2. Turbine blades.

accomplished by one of several methods. One method necessitates loose assembly of the supporting inner and outer vane shrouds. (*Figure 6-3A*)

Each vane fits into a contoured slot in the shrouds, which conforms to the airfoil shape of the vane. These slots are slightly larger than the vanes to give a loose fit. For further support, the inner and outer shrouds are encased by inner and outer support rings, which provide increased strength and rigidity. These support rings also facilitate removal of the nozzle vanes as a unit. Without the rings, the vanes could fall out as the shrouds were removed.

Another method of thermal expansion construction is to fit the vanes into inner and outer shrouds; however, in this method the vanes are welded or riveted into position. (*Figure 6-3B*) Some means must be provided to allow thermal expansion; therefore, either the inner or the outer shroud ring is cut into segments. The saw cuts separating the segments allow sufficient expansion to prevent stress and warping of the vanes.

The rotor element of the turbine section consists essentially of a shaft and a wheel. (*Figure 6-4*) The turbine wheel is a dynamically balanced unit consisting of blades attached to a rotating disk. The disk, in turn, is attached to the main power-transmitting shaft of the engine. The exhaust gases leaving the turbine inlet nozzle vanes act on the blades of the turbine wheel, causing the assembly to rotate at a very high rate of speed. The high rotational speed imposes severe centrifugal loads on the turbine wheel, and at the same time the elevated temperatures result in a lowering of the strength of the material. Consequently, the engine speed and temperature must be controlled to keep turbine operation within safe limits.

The turbine disk is referred to as such without blades. When the turbine blades are installed, the disk then becomes the turbine wheel. The disk acts as an anchoring component for the turbine blades. Since the disk is bolted or welded to the shaft, the blades can transmit to the rotor shaft the energy they extract from the exhaust gases.

The disk rim is exposed to the hot gases passing through the blades and absorbs considerable heat from these gases. In addition, the rim also absorbs heat from

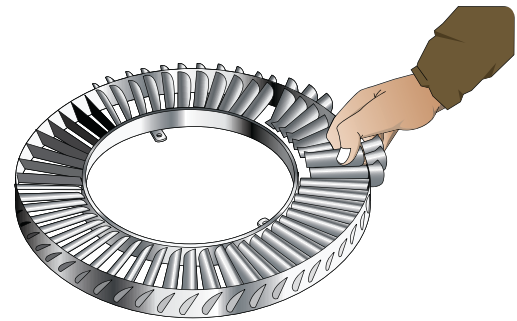

A. Turbine nozzle vane assembly with loose-fitting vanes.



B. Turbine nozzle vane assembly with welded vanes.

Figure 6-3. Typical turbine nozzle vane assemblies.

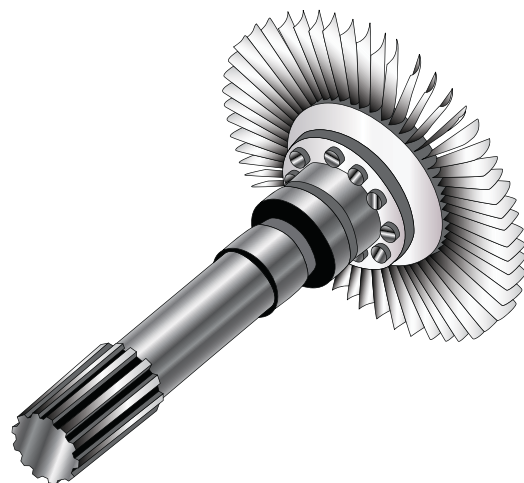

Figure 6-4. Rotor elements of the turbine assembly.

the turbine blades by conduction. Hence, disk rim temperatures are normally high and well above the temperatures of the more remote inner portion of the disk. As a result of these temperature gradients, thermal stresses are added to the rotational stresses.

There are various methods to relieve, at least partially, the aforementioned stresses. One such method is to bleed cooling air back onto the face of the disk. Another method of relieving the thermal stresses of the disk is incidental to blade installation. A series of grooves or notches, conforming to the blade root design, are broached in the rim of the disk. These grooves allow

attachment of the turbine blades to the disk; at the same time, space is provided by the notches for thermal expansion of the disk. Sufficient clearance exists between the blade root and the notch to permit movement of the turbine blade when the disk is cold. During engine operation, expansion of the disk decreases the clearance. This causes the blade root to fit tightly in the disk rim.

The turbine shaft is usually fabricated from alloy steel. (*Figure 6-4*) It must be capable of absorbing the high torque loads that are exerted on it. The methods of connecting the shaft to the turbine disk vary.

In one method, the shaft is welded to the disk, which has a butt or protrusion provided for the joint. Another method is by bolting. This method requires that the shaft have a hub that fits a machined surface on the disk face. Then, the bolts are inserted through holes in the shaft hub and anchored in tapped holes in the disk. Of the two connection methods, bolting is more common.

The turbine shaft must have some means for attachment to the compressor rotor hub. This is usually accomplished by a spline cut on the forward end of the shaft. The spline fits into a coupling device between the compressor and turbine shafts. If a coupling is not used, the splined end of the turbine shaft may fit into a splined recess in the compressor rotor hub. This splined coupling arrangement is used almost exclusively with centrifugal compressor engines, while axial compressor engines may use either of these described methods.

There are various ways of attaching turbine blades, some similar to compressor blade attachment. The most satisfactory method uses the fir-tree design. (*Figure 6-5*)

The blades are retained in their respective grooves by a variety of methods, the more common of which are peening, welding, lock tabs, and riveting. *Figure 6-6* shows a typical turbine wheel using rivets for blade retention. The peening method of blade retention is used frequently in various ways. One of the most common applications of peening requires a small notch to be ground in the edge of the blade fir-tree root prior to the blade installation. After the blade is inserted into the disk, the notch is filled by the disk metal, which is "flowed" into it by a small punch-mark made in the disk adjacent to the notch. The tool used for this job is similar to a center punch.

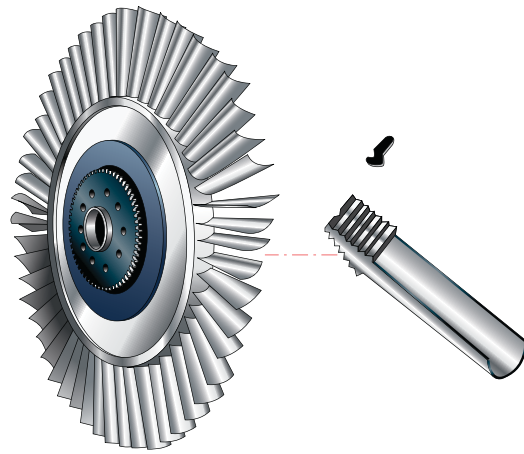

Figure 6-5. Turbine blade with fir-tree design and lock-tab method of blade retention.

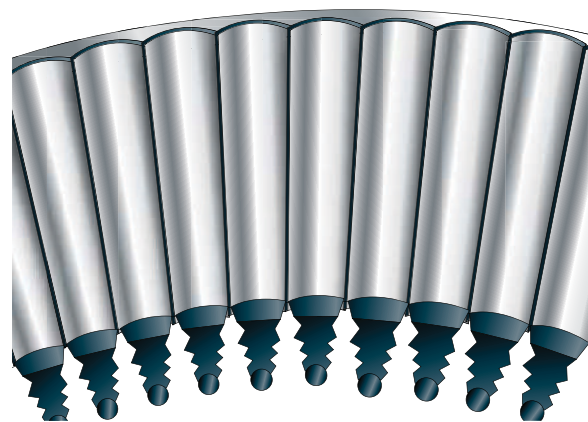

Figure 6-6. Rivet method of turbine blade retention.

Another method of blade retention is to construct the root of the blade so that it contains all the elements necessary for its retention. This method uses the blade root as a stop made on one end of the root so that the blade can be inserted and removed in one direction only, while on the opposite end is a tang. This tang is bent to secure the blade in the disk.

Turbine blades may be either forged or cast, depending on the composition of the alloys. Most blades are precision cast and finish ground to the desired shape. Many turbine blades are cast as a single crystal, which gives the blades better strength and heat properties. Heat barrier coating, such as ceramic coating, and air flow cooling help keep the turbine blades and inlet nozzles cooler. This allows the exhaust temperature to be raised, increasing the efficiency of the engine. *Figure 6-7* shows a turbine blade with air holes for cooling purposes.

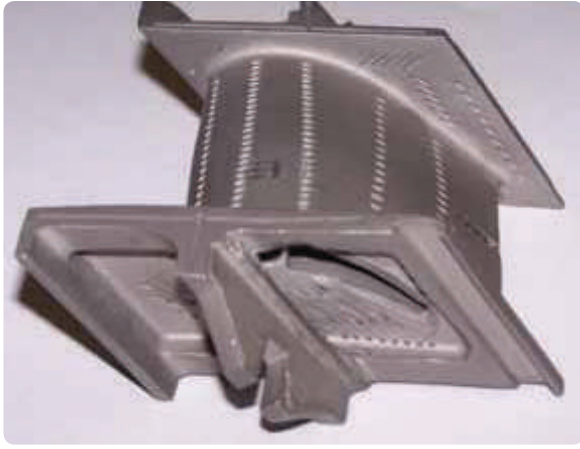

Figure 6-7. Turbine blade with cooling holes.

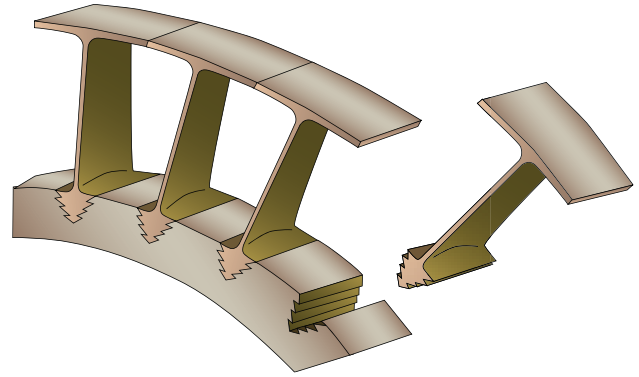

Figure 6-8. Shrouded turbine blades.

Most turbines are open at the outer perimeter of the blades; however, a second type called the shrouded turbine is sometimes used. The shrouded turbine blades, in effect, form a band around the outer perimeter of the turbine wheel. This improves efficiency and vibration characteristics, and permits lighter stage weights. On the other hand, it limits turbine speed and requires more blades. (*Figure 6-8*)

In turbine rotor construction, it occasionally becomes necessary to utilize turbines of more than one stage. A single turbine wheel often cannot absorb enough power from the exhaust gases to drive the components dependent on the turbine for rotative power; thus, it is necessary to add additional turbine stages.

A turbine stage consists of a row of stationary vanes or nozzles, followed by a row of rotating blades. In some models of turboprop engine, as many as five turbine stages have been utilized successfully. It should be remembered that, regardless of the number of wheels necessary for driving engine components, there is always a turbine nozzle preceding each wheel.

As was brought out in the preceding discussion of turbine stages, the occasional use of more than one turbine wheel is warranted in cases of heavy rotational loads. It should also be pointed out that the same loads that necessitate multistage turbines often make it advantageous to incorporate multiple compressor rotors.

In the single-stage rotor turbine, the power is developed by one turbine rotor, and all engine-driven parts are driven by this single wheel. (*Figure 6-9*)

This arrangement is used on engines where the need for low weight and compactness predominates. This is the simplest version of the pure turbojet engine. A multistage turbine is shown in *Figure 6-10*.

In multiple spool engines, each spool has its own set of turbine stages. Each set of turbine stages turns the compressor attached to it. Most turbofan engines have two spools: low pressure (fan shaft a few stages of compression and the turbine to drive it) and high pressure (high pressure compressor shaft and high pressure turbine). (*Figure 6-11*)

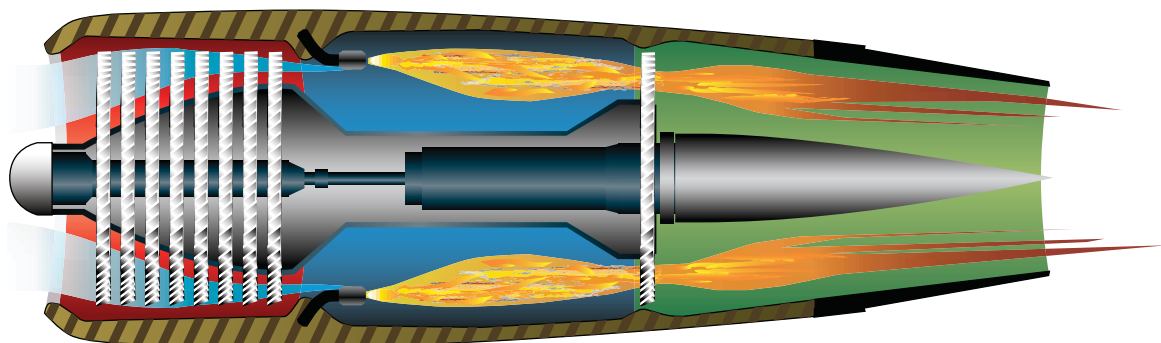

Figure 6-9. Single-stage rotor turbine.

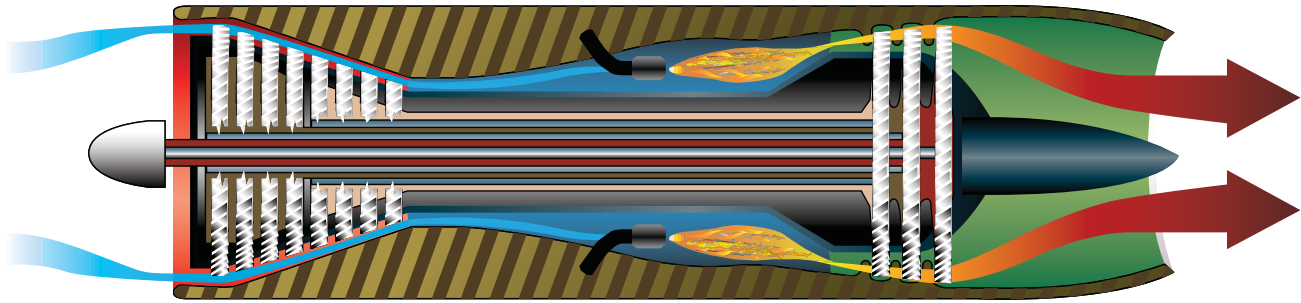

Figure 6-10. Multirotor turbine.

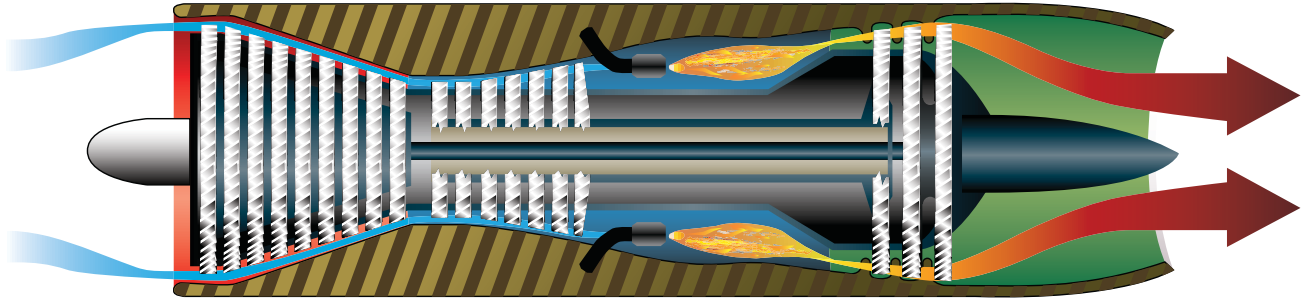

Figure 6-11. Dual-rotor turbine for split-spool compressor.

The remaining element to be discussed concerning turbine familiarization is the turbine casing or housing. The turbine casing encloses the turbine wheel and the nozzle vane assembly, and at the same time gives either direct or indirect support to the stator elements of the turbine section. It always has flanges provided front and rear for bolting the assembly to the combustion chamber housing and the exhaust cone assembly, respectively. A turbine casing is illustrated in *Figure 6-12*.

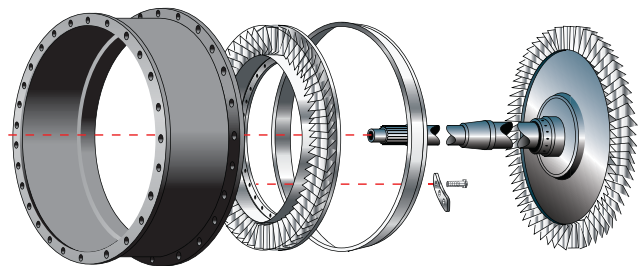

Figure 6-12. Turbine casing assembly.

Inspection for cracks in turbine section components is very important. Cracks are not normally allowed. Crack detection, when dealing with the turbine disk and blades, is mostly visual, although structural inspection techniques can be used, such as penetrant methods and others to aid in the inspection. Cracks on the disk necessitate the rejection of the disk and replacement of the turbine rotor. Slight pitting caused by the impingement of foreign matter may be blended by stoning and polishing.

Because of the extreme heat under which the turbine blades operate, they are susceptible to damage. Strong light and a magnifying glass are used for inspection of turbine blades for stress rupture cracks and deformation of the leading edge. (*Figures 6-13 and 6-14*)

Stress rupture cracks usually appear as minute hairline cracks on or across the leading or trailing edge at a right angle to the edge length. Visible cracks may range in length from one-sixteenth inch upward. Deformation caused by over-temperature, may appear as waviness and/or areas of varying airfoil thickness along the leading edge. The leading edge must be straight and of uniform thickness along its entire length, except for areas repaired by blending. Do not confuse stress rupture cracks or deformation of the leading edge with foreign material impingement damage or with blending repairs to the blade. When any stress rupture cracks or deformation of the leading edges of the first-stage turbine blades are found, an over-temperature condition can be suspected.

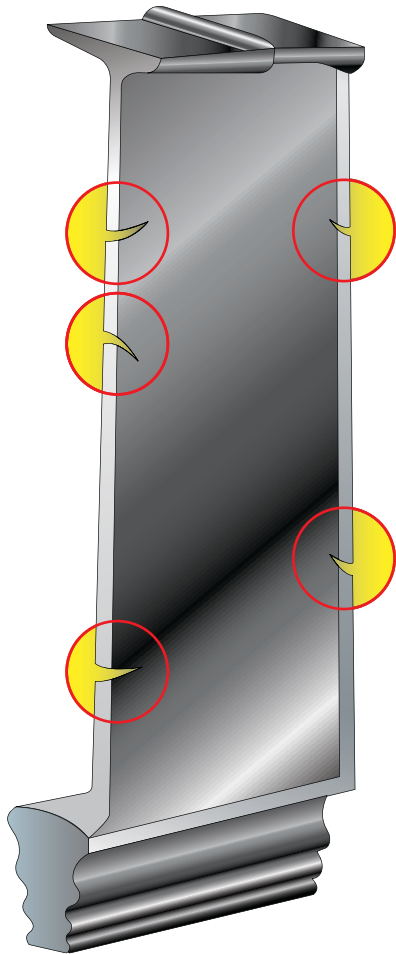

Figure 6-13. Stress rupture cracks.

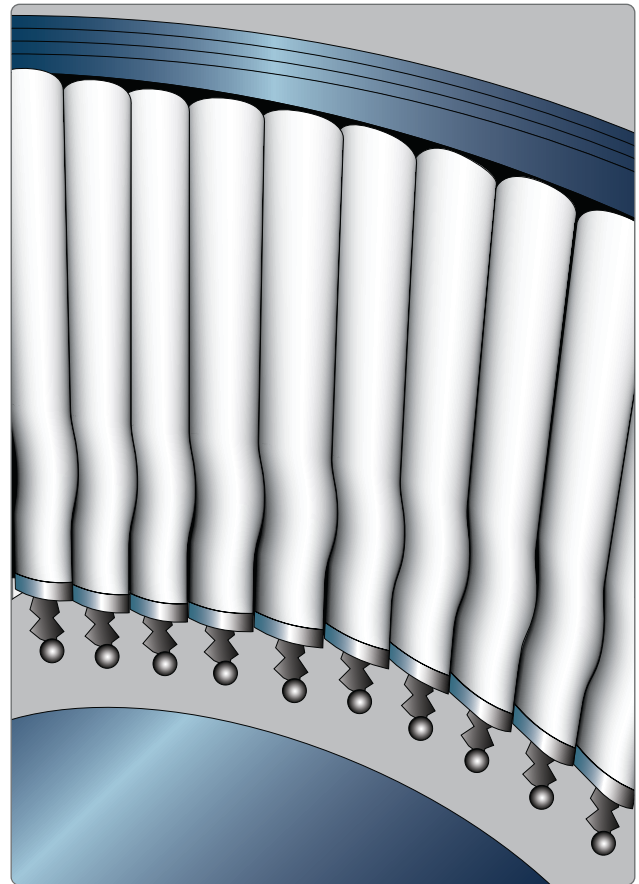

Figure 6-14. Turbine blade waviness.

Materials such as metals and plastics also experience creep. This is a slow structural deformation on a molecular level caused by prolonged exposure to high stresses. The extreme temperatures in the turbine area of an turbine engine promote creep in turbine blades. Creep increases with temperature and can result in observable dimensional changes to the blades. Therefore, dimensional inconsistency could be caused creep rather than over temperature. Blades should be inspected and measured in accordance with manufacturer's instructions. Signs of scoring on the turbine case may indicate the length of turbine blades is out of tolerance. Adhere to all manufacturer's specifications when observing and measuring blade deformation. Replace any damaged turbine blades as specified.

Check the individual blades for stretch and the turbine disk for hardness and stretch. Blades removed for a detailed inspection or for a check of turbine disk stretch must be re- installed in the same slots from which they were removed. Number the blades prior to removal.



*Question:* 6-1

Where is the highest or hottest temperature that comes in contact with metal components in a gas turbine engine?

*Question:* 6-4

What is the hottest component in an operating turbine engine?

*Question:* 6-2

Most turbofan engines have \_\_\_\_\_ spools (number).

*Question:* 6-5

What is the main purpose of the stationary turbine inlet vanes?

*Question:* 6-3

What is the primary cause of turbine blade damage?

*Question:* 6-6

What type of turbine blade produces the last internal vibration?



## ANSWERS

*Answer:* 6-1

Turbine inlet guide vanes (also known as turbine inlet nozzle vanes or the nozzle diaphragm).

*Answer:* 6-4

Turbine inlet nozzle vanes.

*Answer:* 6-2

two - a low pressure spool and a high pressure spool.

*Answer:* 6-5

To direct the airflow coming out of the combustion chamber to the proper angle of rotation to turn the turbine wheel.

*Answer:* 6-3

Extreme heat.

*Answer:* 6-6

Shrouded blades.



PART-66 SYLLABUS LEVELS  
 CERTIFICATION CATEGORY → **A1** **B1**

**Sub-Module 07**  
**EXHAUST**  
 Knowledge Requirements

*15.7 - Exhaust*

- Constructional features and principles of operation;
- Convergent, divergent and variable area nozzles;
- Engine noise reduction;
- Thrust reverser's.

CERTIFICATION CATEGORY →	A1	B1
	<b>1</b>	<b>2</b>

**Level 1**

A familiarization with the principal elements of the subject.

*Objectives:*

- (a) The applicant should be familiar with the basic elements of the subject.
- (b) The applicant should be able to give a simple description of the whole subject, using common words and examples.
- (c) The applicant should be able to use typical terms.

**Level 2**

A general knowledge of the theoretical and practical aspects of the subject and an ability to apply that knowledge.

*Objectives:*

- (a) The applicant should be able to understand the theoretical fundamentals of the subject.
- (b) The applicant should be able to give a general description of the subject using, as appropriate, typical examples.
- (c) The applicant should be able to use mathematical formula in conjunction with physical laws describing the subject.
- (d) The applicant should be able to read and understand sketches, drawings and schematics describing the subject.
- (e) The applicant should be able to apply his knowledge in a practical manner using detailed procedures.

EXHAUST

## EXHAUST SECTION

The exhaust section of the gas turbine engine consists of several components. Although the components have individual purposes, they also have one common function: they must direct the flow of hot gases rearward in such a manner as to prevent turbulence and, at the same time, impart a high final or exit velocity to the gases. In performing the various functions, each of the components affects the flow of gases in different ways.

The exhaust section is located directly behind the turbine section and ends when the gases are ejected at the rear in the form of a high-velocity exhaust gases. The components of the exhaust section include the exhaust cone, tailpipe (if required), and the exhaust nozzle. The exhaust cone collects the exhaust gases discharged from the turbine section and gradually converts them into a solid flow of gases. In performing this, the velocity of the gases is decreased slightly and the pressure increased. This is due to the diverging passage between the outer duct and the inner cone; that is, the annular area between the two units increases rearward.

The exhaust cone assembly consists of an outer shell or duct, an inner cone, three or four radial hollow struts or fins, and the necessary number of tie rods to aid the struts in supporting the inner cone from the outer duct. The outer shell or duct is usually made of stainless steel and is attached to the rear flange of the turbine case. This element collects the exhaust gases and delivers them directly to the exhaust nozzle. The duct must be constructed to include such features as a predetermined number of thermocouple bosses for installing exhaust temperature thermocouples, and there must also be insertion holes for the supporting tie rods. In some cases, tie rods are not used for supporting the inner cone. If such is the case, the hollow struts provide the sole support of the inner cone, the struts being spot-welded in position to the inside surface of the duct and to the inner cone, respectively. (*Figure 7-1*)

The radial struts actually have a twofold function. They not only support the inner cone in the exhaust duct, but they also perform the important function of straightening the swirling exhaust gases that would otherwise leave the turbine at an angle of approximately 45°. The centrally located inner cone fits rather closely against the rear face of the turbine disk, preventing

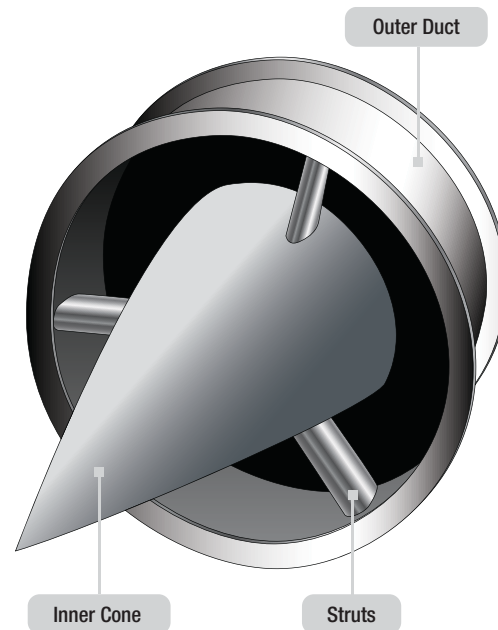

Figure 7-1. Exhaust collector with welded support struts.

turbulence of the gases as they leave the turbine wheel. The cone is supported by the radial struts. In some configurations, a small hole is located in the exit tip of the cone. This hole allows cooling air to be circulated from the aft end of the cone, where the pressure of the gases is relatively high, into the interior of the cone and consequently against the face of the turbine wheel. The flow of air is positive, since the air pressure at the turbine wheel is relatively low due to rotation of the wheel; thus air circulation is assured.

The gases used for cooling the turbine wheel return to the main path of flow by passing through the clearance between the turbine disk and the inner cone. The exhaust cone assembly is the terminating component of the basic engine. The remaining component (the exhaust nozzle) is usually considered an airframe component.

The tailpipe is usually constructed so that it is semi-flexible. On some tailpipes, a bellows arrangement is incorporated in its construction, allowing movement in installation, maintenance, and in thermal expansion. This eliminates stress and warping which would otherwise be present. The heat radiation from the exhaust cone and tailpipe could damage the airframe components surrounding these units. For this reason, some means of insulation had to be devised. There are

several suitable methods of protecting the fuselage structure; two of the most common are insulation blankets and shrouds.

The insulation blanket, illustrated in *Figures 7-2 and 7-3*, consists of several layers of aluminum foil, each separated by a layer of fiberglass or some other suitable material. Although these blankets protect the fuselage

from heat radiation, they are used primarily to reduce heat loss from the exhaust system. The reduction of heat loss improves engine performance. There are two types of exhaust nozzle designs: the converging design for subsonic gas velocities and the converging diverging design for supersonic gas velocities.

The exhaust nozzle opening may be of either fixed or variable area. The fixed-area type is the simpler of the two exhaust nozzles since there are no moving parts. The outlet area of the fixed exhaust nozzle is very critical to engine performance. If the nozzle area is too large, thrust is wasted; if the area is too small, the engine could choke or stall. A variable-area exhaust nozzle is used when an augmentor or afterburner is used due to the increased mass of flow when the afterburner is activated. It must increase its open area when the afterburner is selected. When the afterburner is off, the exhaust nozzle closes to a smaller area of opening.

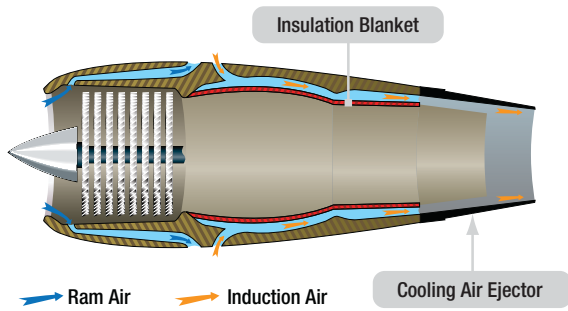

Figure 7-2. Exhaust system insulation blanket.

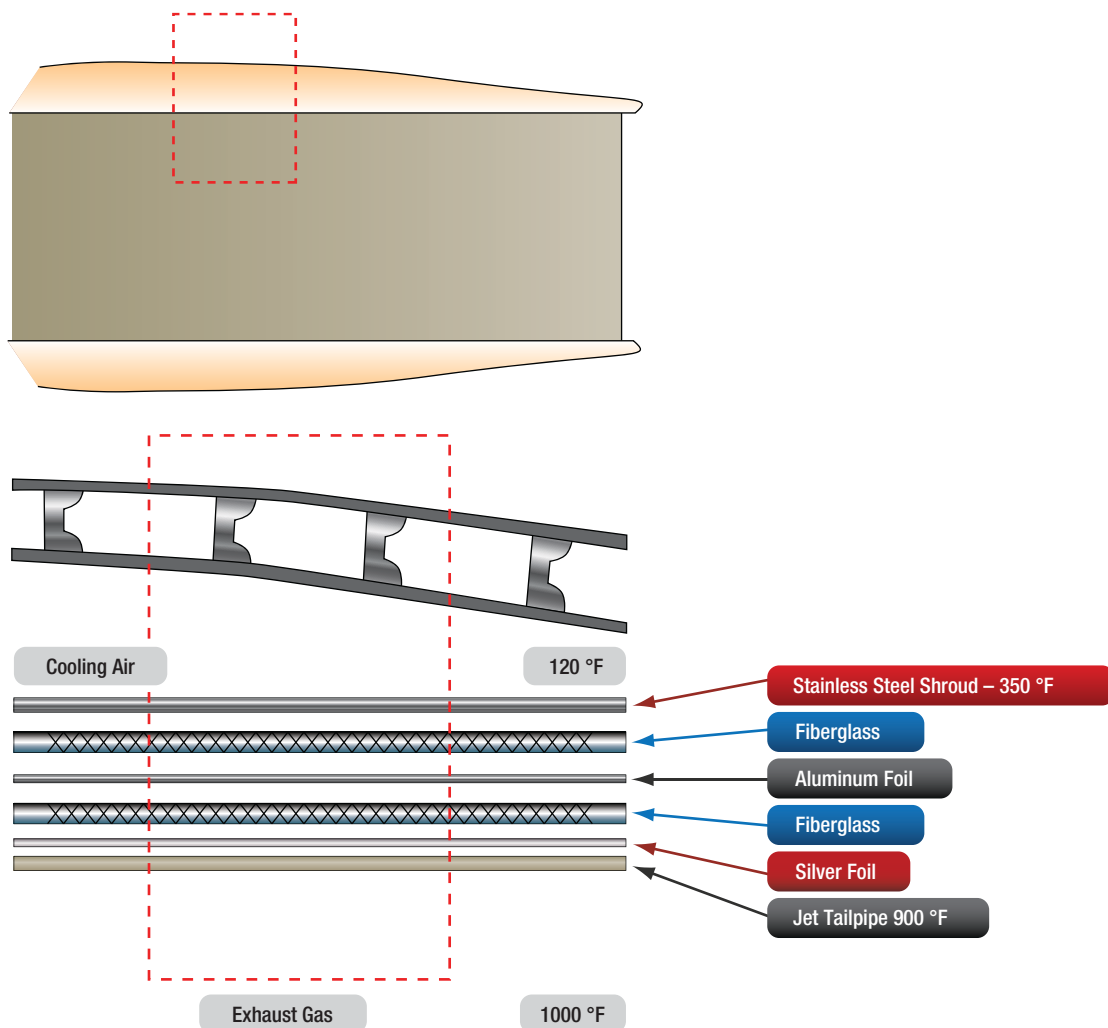

Figure 7-3. Insulation blanket with the temperatures obtained at the various locations shown.

## EXHAUST NOZZLES

Turbine engines actually have several different types of exhaust nozzles depending upon the type of engine. Turboshaft engines in helicopters can have an exhaust nozzle that forms a divergent duct. This type of nozzle provides no thrust. All engine power is used to rotate the rotors, improving helicopter hovering abilities. Turbofan engines tend to fall into either ducted fan or unducted fan engines. Ducted fan engines take the fan airflow and direct it through closed ducts along the engine. Then, it flows into a common exhaust nozzle. The core exhaust flow and the fan flow mix and flow from the engine through this mixed nozzle. The unducted fan has two nozzles, one for the fan airflow and one for the core airflow. These both flow to ambient air separate from each other and have separate nozzles. (*Figure 7-4*)

The unducted engine or the separate nozzle engine handles high amounts of airflow. The fan air which creates most of the thrust (80–85 percent total thrust) must be directed through the exit vanes with as little turbulence as possible. (*Figure 7-5*) The core airflow needs to be straightened as it comes from the turbine. Through the use of a converging nozzle, the exhaust gases increase in velocity before they are discharged from the exhaust nozzle. Increasing the velocity of the gases increases their momentum and increases the thrust produced (20–15 percent total thrust). Most of the energy of the gases have been absorbed to drive the fan through the low-pressure turbine stages.

Turboprop exhaust nozzles provide small amounts of thrust (10–15 percent), but are mainly used to discharge the exhaust gases from the aircraft. Most of the energy

has been transferred to the propeller. On some turboprop aircraft, an exhaust duct is often referred to as a tailpipe, although the duct itself is essentially a simple, stainless steel, conical or cylindrical pipe. The assembly also includes an engine tail cone and the struts inside the duct. The tail cone and the struts add strength to the duct, impart an axial direction to the gas flow, and smooth the gas flow. In a typical installation, the tailpipe assembly is mounted in the nacelle and attached at its forward end to the firewall. The forward section of the tailpipe is funnel shaped and surrounds but does not contact the turbine exhaust section. This arrangement forms an annular gap that serves as an air ejector for the air surrounding the engine hot section. As the high-velocity exhaust gases enter the tailpipe, a low-pressure effect is produced which causes the air around the engine hot section to flow through the annular gap into the tailpipe.

The rear section of the tailpipe is secured to the airframe by two support arms, one on each side of the tailpipe. The support arms are attached to the upper surface of the wing in such a way that allow movement fore and aft to compensate for expansion. The tailpipe assembly is wrapped in an insulating blanket to shield the surrounding area from the high heat produced by the exhaust gases. Such blankets may be made of a stainless steel laminated sheet on the outside and fiberglass on the inside. This is used when the engine exhaust is located some distance from the edge of the wing or aircraft structure.

Immediately aft of the turbine outlet, and usually just forward of the flange to which the exhaust duct is attached, the engine is instrumented for turbine

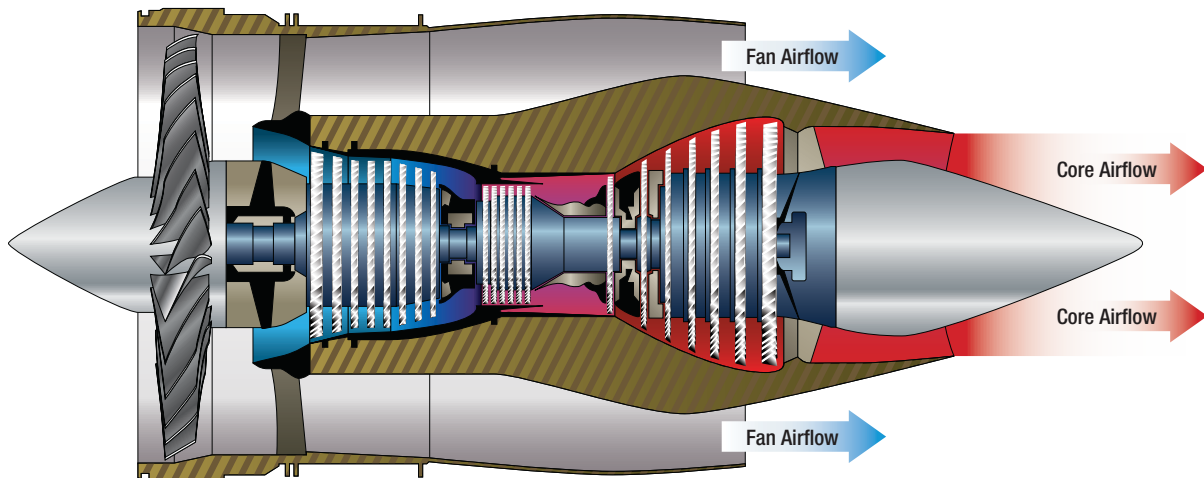

Figure 7-4. Paths of core exhaust flow and fan flow from the engine through separate nozzles.



Figure 7-5. Air from these fan blades must be straightened.

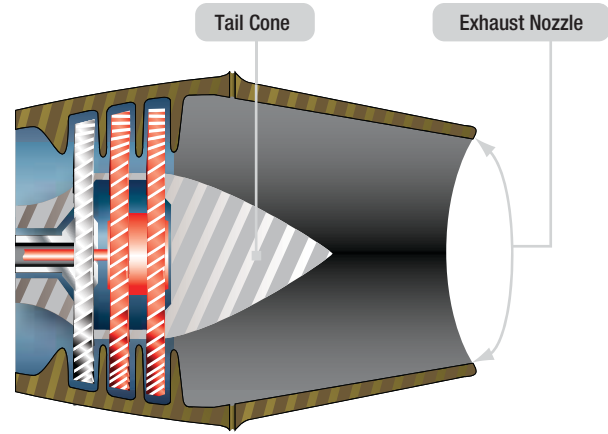

Figure 7-6. Exhaust gases exit the rear of the engine through the exhaust nozzle.

discharge pressure. One or more pressure probes are inserted into the exhaust duct to provide adequate sampling of the exhaust gases. In large engines, it is not practical to measure the internal temperature at the turbine inlet, so the engine is often also instrumented for exhaust gas temperature at the turbine outlet.

### CONVERGENT EXHAUST NOZZLE

As the exhaust gases exit the rear of the engine, they flow into the exhaust nozzle. (Figure 7-6) The very first part of the exhaust nozzle and the exhaust plug form a divergent duct to reduce turbulence in the airflow, then the exhaust gases flow into the convergent component of the exhaust nozzle where the flow is restricted by a smaller outlet opening. Since this forms a convergent duct, the gas velocity is increased providing increased thrust.

The restriction of the opening of the outlet of the exhaust nozzle is limited by two factors. If the nozzle opening is too big, thrust is being wasted. If it is too little, the flow is choked in the other components of the engine. In other words, the exhaust nozzle acts as an orifice, the size of which determines the density and velocity of the gases as they emerge from the engine. This is critical to thrust performance.

Adjusting the area of the exhaust nozzle changes both the engine performance and the exhaust gas temperature. When the velocity of the exhaust gases at the nozzle opening becomes Mach 1, the flow passes only at this speed—it does not increase or decrease. Sufficient flow to maintain Mach 1 at the nozzle opening and have extra flow (flow that is being restricted by the opening)

creates what is called a choked nozzle. The extra flow builds up pressure in the nozzle, which is sometimes called pressure thrust. A differential in pressure exists between the inside of the nozzle and the ambient air. By multiplying this difference in pressure times the area of the nozzle opening, pressure thrust can be calculated. Many engines cannot develop pressure thrust because most of the energy is used to drive turbines that turn propellers, large fans, or helicopter rotors.

### CONVERGENT-DIVERGENT EXHAUST NOZZLE

Whenever the engine pressure ratio is high enough to produce exhaust gas velocities which might exceed Mach 1 at the engine exhaust nozzle, more thrust can be gained by using a convergent-divergent type of nozzle. (Figure 7-7) The advantage of a convergent-divergent nozzle is greatest at high Mach numbers because of the resulting higher pressure ratio across the engine exhaust nozzle.

To ensure that a constant weight or volume of a gas flows past any given point after sonic velocity is reached, the rear part of a supersonic exhaust duct is enlarged to accommodate the additional weight or volume of a gas that flows at supersonic rates. If this is not done, the nozzle does not operate efficiently. This is the divergent section of the exhaust duct.

When a divergent duct is used in combination with a conventional exhaust duct, it is called a convergent-divergent exhaust duct. In the convergent-divergent, or C-D nozzle, the convergent section is designed to handle the gases while they remain subsonic, and to

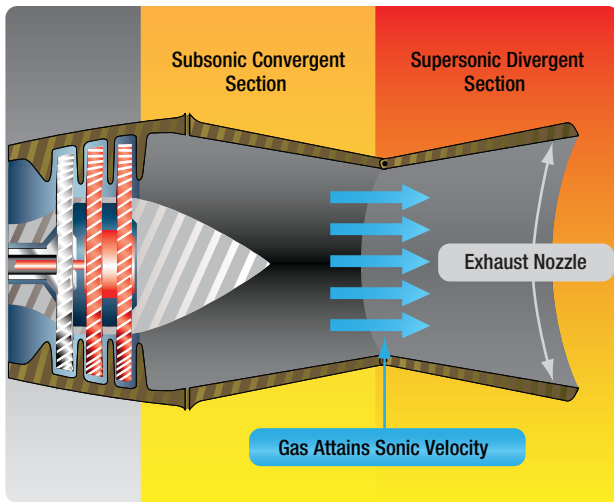

Figure 7-7. A convergent-divergent nozzle can be used to help produce more thrust when exhaust gas velocities are greater than Mach 1.

deliver the gases to the throat of the nozzle just as they attain sonic velocity. The divergent section handles the gases, further increasing their velocity, after they emerge from the throat and become supersonic. As the gas flows from the throat of the nozzle, it becomes supersonic (Mach 1 and above) and then passes into the divergent section of the nozzle. Since it is supersonic, it continues to increase in velocity. This type of nozzle is generally used on very high speed aerospace vehicles.

## THRUST REVERSER'S

As aircraft have increased in gross weights with higher landing airspeeds, the problem of stopping an aircraft after landing has greatly increased. In many instances, the aircraft brakes can no longer be relied upon solely to slow the aircraft within a reasonable distance, immediately after touchdown. Most thrust reverser systems can be divided into two categories: mechanical-blockage and aerodynamic-blockage.

Mechanical blockage is accomplished by placing a removable obstruction in the exhaust gas stream, usually somewhat to the rear of the nozzle. The engine exhaust gases are mechanically blocked and diverted at a suitable angle in the reverse direction by an inverted cone, half-sphere, or clam shell. (Figure 7-8) This is placed in position to reverse the flow of exhaust gases. This type is generally used with ducted turbofan engines, where the fan and core flow mix in a common nozzle before exiting the engine. The clamshell-type or mechanical-blockage reverser operates to form a barrier in the path of escaping exhaust gases, which nullifies and reverses the forward thrust of the engine. The reverser system must be able to

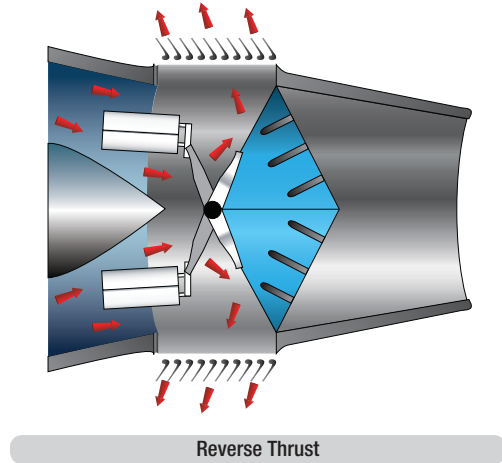
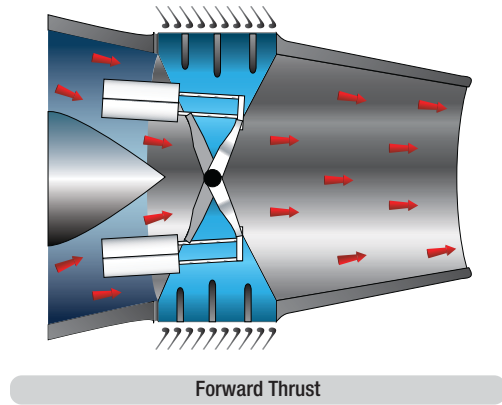

Figure 7-8. Engine exhaust gases are blocked and diverted in a reverse direction during thrust reversal.

withstand high temperatures, be mechanically strong, relatively light in weight, reliable, and "fail-safe." When not in use, it must be streamlined into the configuration of the engine nacelle. When the reverser is not in use, the clamshell doors retract and nest neatly around the engine exhaust duct, usually forming the rear section of the engine nacelle.

In the aerodynamic blockage type of thrust reverser, used mainly with unducted turbofan engines, only fan air is used to slow the aircraft. A modern aerodynamic thrust reverser system consists of a translating cowl, blocker doors, and cascade vanes that redirect the fan airflow to slow the aircraft. (Figure 7-9)

If the thrust levers are at idle position and the aircraft has weight on the wheels, moving the thrust levers aft activates the translating cowl to open closing the blocker doors. This action stops the fan airflow from going aft and redirects it through the cascade vanes, which direct the airflow forward to slow the aircraft. Since the fan can produce approximately 80 percent of the engine's thrust,

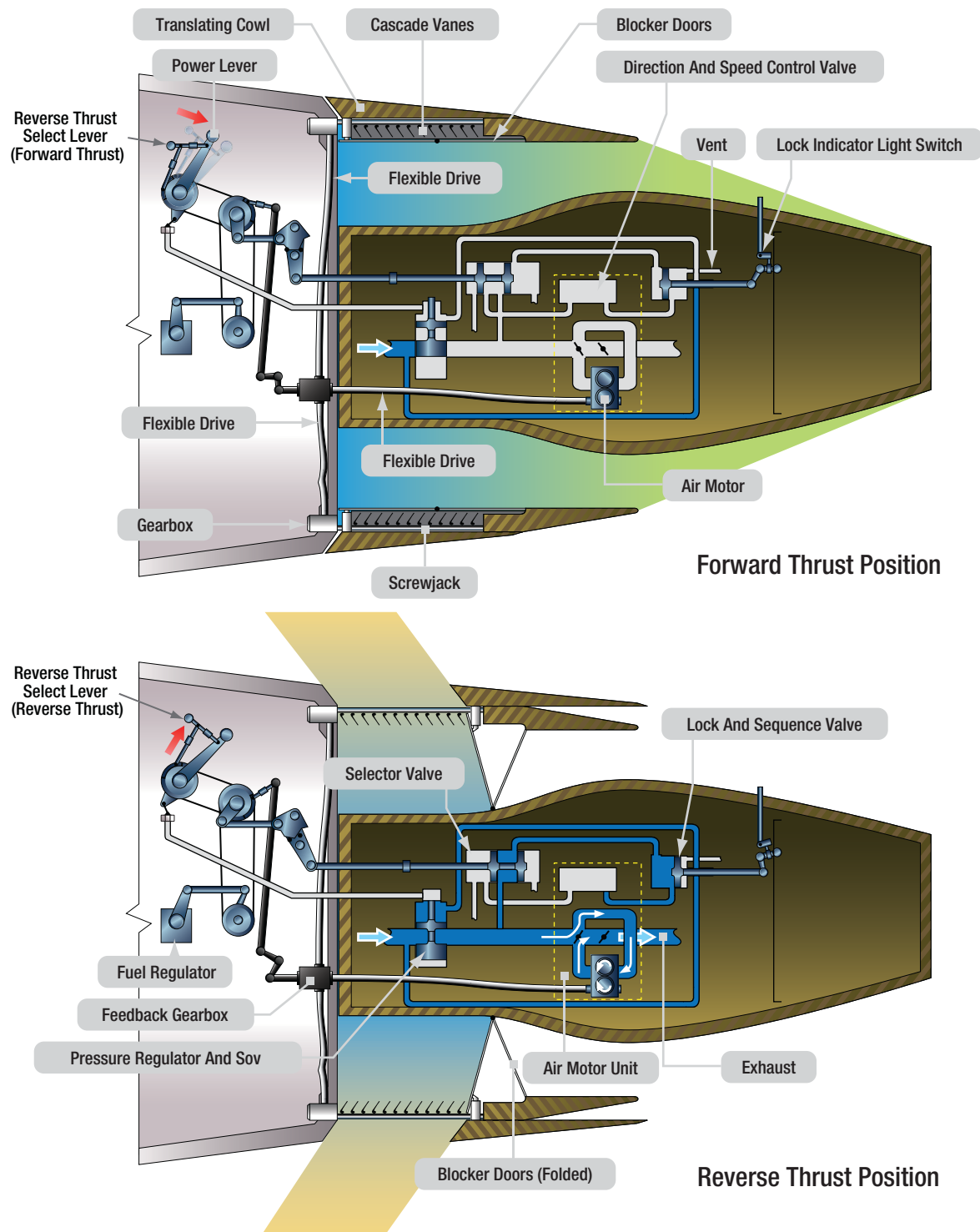

Figure 7-9. Components of a thrust reverser system.

the fan is the best source for reverse thrust. By returning the thrust levers (power levers) to the idle position, the blocker doors open and the translating cowl closes.

A thrust reverser must not have any adverse effect on engine operation either deployed or stowed. Generally, there is an indication in the flight deck with regard to the status of the reverser system. The thrust reverser system

consists of several components that move either the clam shell doors or the blocker door and translating cowl. Actuating power is generally pneumatic or hydraulic and uses gearboxes, flexdrives, screwjacks, control valves, and air or hydraulic motors to deploy or stow the thrust reverser systems. The systems are locked in the stowed position until commanded to deploy by the flight deck. Since there are several moving parts, maintenance and

EXHAUST



inspection requirements are very important. While performing any type of maintenance, the reverser system must be mechanically locked out from deploying while personnel are in the area of the reverser system.

### THRUST VECTORING

Thrust vectoring is the ability of an aircraft's main engines to direct thrust other than parallel to the vehicle's longitudinal axis, allowing the exhaust nozzle to move or change position to direct the thrust in varied directions. Vertical takeoff aircraft use thrust vectoring as takeoff thrust and then change direction to propel the aircraft in horizontal flight. Military aircraft use thrust vectoring for maneuvering in flight to change direction. Thrust vectoring is generally accomplished by relocating the direction of the exhaust nozzle to direct the thrust to move the aircraft in the desired path. At the rear of a gas turbine engine, a nozzle directs the flow of hot exhaust gases out of the engine and afterburner. Usually, the nozzle points straight out of the engine. The pilot can move, or vector, the vectoring nozzle up and down by 20°. This makes the aircraft much more maneuverable in flight. (Figure 7-10)

### ENGINE NOISE SUPPRESSION

Aircraft powered by gas turbine engines sometimes require noise suppression for the engine exhaust gases when operating from airports located in or near highly populated areas. Several types of noise suppressor are used. A common type of noise suppressor is an integral, airborne part of the aircraft engine installation or engine exhaust nozzle. Engine noise comes from several sources on the engine, the fan, or compressor and the



Figure 7-10. A pilot can direct thrust via the vectoring nozzle 20° up or down to increase flight maneuverability.

air discharge from the core of the engine. There are three sources of noise involved in the operation of a gas turbine engine. The engine air intake and vibration from engine housing are sources of some noise, but the noise generated does not compare in magnitude with that produced by the engine exhaust. (Figure 7-11)

The noise produced by the engine exhaust is caused by the high degree of turbulence of a high-velocity jet stream moving through a relatively quiet atmosphere. For a distance of a few nozzle diameters downstream behind the engine, the velocity of the jet stream is high, and there is little mixing of the atmosphere with the jet stream. In this region, the turbulence within the high speed jet stream is very fine grain turbulence, and produces relatively high-frequency noise. This noise is caused by violent, turbulent mixing of the exhaust gases with the atmosphere and is influenced by the shearing action caused by the relative speeds between the velocity and the atmosphere.

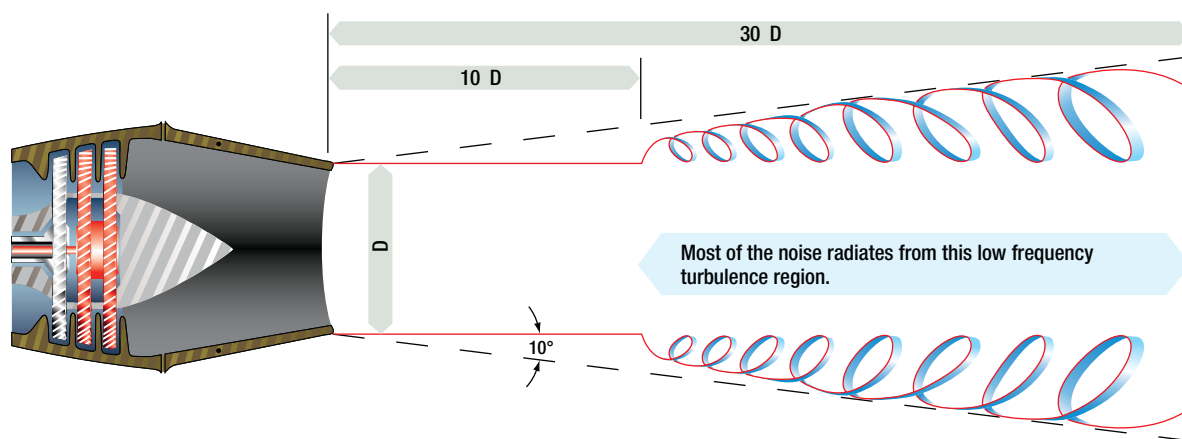

D = Nozzle Diameter

Figure 7-11. Engine noise from engine exhaust is created by the turbulence of a high velocity jet stream moving through the relatively quiet atmosphere.

Farther downstream, as the velocity of the jet stream slows down, the jet stream mixes with the atmosphere and turbulence of a coarser type begins. Compared with noise from other portions of the jet stream, noise from this portion has a much lower frequency. As the energy of the jet stream finally is dissipated in large turbulent swirls, a greater portion of the energy is converted into noise. The noise generated as the exhaust gases dissipate is at a frequency near the low end of the audible range. The lower the frequency of the noise, the greater the distance the noise travels. This means that the low-frequency noises reach an individual on the ground in greater volume than the high-frequency noises, and hence are more objectionable. High-frequency noise is weakened more rapidly than low frequency noise, both by distance and the interference of buildings, terrain, and atmospheric disturbances. A deep-voiced, low-frequency foghorn, for example, may be heard much farther than a shrill, high-frequency whistle, even though both may have the same overall volume (decibels) at their source.

Noise levels vary with engine thrust and are proportional to the amount of work done by the engine on the air that passes through it. An engine having relatively low airflow but high thrust due to high turbine discharge (exhaust gas) temperature, pressure, and/or after burning produces a gas stream of high velocity and, therefore, high noise levels. A larger engine, handling more air, is quieter at the same thrust. Thus, the noise level can be reduced considerably by operating the engine at lower power settings, and large engines operating at partial thrust are less noisy than smaller engines operating at full thrust. Compared with a turbojet, a turbofan version of the same engine is quieter during takeoff. The noise level produced by a fan-type engine is less, principally because the exhaust gas velocities ejected at the engine tailpipe are slower than those for a turbojet of comparative size.

Fan engines require a larger turbine to provide additional power to drive the fan. The large turbine, which usually has an additional turbine stage, reduces the velocity of the gas and, therefore, reduces the noise produced because exhaust gas noise is proportional to exhaust gas velocity. The exhaust from the fan is at a relatively low velocity and, therefore, does not create a noise problem. Because of the characteristic of low-frequency noise to linger at a relatively high volume, effective noise

reduction for a turbojet aircraft must be achieved by revising the noise pattern or by changing the frequency of the noise emitted by the jet nozzle.

The noise suppressors in current use are either of the corrugated perimeter type, or the multi-tube type. (Figure 7-12) Both types of suppressors break up the single, main jet exhaust stream into a number of smaller jet streams. This increases the total perimeter of the nozzle area and reduces the size of the air stream eddies created as the gases are discharged into the open air. Although the total noise-energy remains unchanged, the frequency is raised considerably. The size of the air stream eddies scales down at a linear rate with the size of the exhaust stream. This has two effects:

1. The change in frequency may put some of the noise above the audibility range of the human ear, and
2. High frequencies within the audible range, while perhaps more annoying, are more highly attenuated by atmospheric absorption than are low frequencies. Thus, the falloff in intensity is greater and the noise level is less at any given distance from the aircraft.

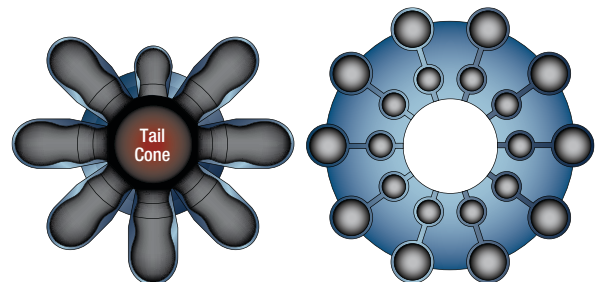

Figure 7-12. Noise suppressors currently in use are corrugated perimeter type, or multi-tube type.

In the engine nacelle, the area between the engine and the cowl has acoustic linings surrounding the engine. This noise-absorbing lining material converts acoustic energy into heat. These linings normally consist of a porous skin supported by a honeycomb backing and provide a separation between the fact sheet and the engine duct. For optimum suppression, the acoustic properties of the skin and the liner are carefully matched.

## TURBINE ENGINE EMISSIONS

Engineers are introducing new combustion technology that has dramatically reduced emissions from gas turbine engines. Lowering exhaust emissions from gas turbine, especially oxides of nitrogen (NOX), continue to require improvement. Most of the research has centered around the combustion section of the engine. New technology with unique combustor design has greatly reduced emissions. One manufacturer has a design called the Twin Annular, Pre-mixing Swirler (TAPS) combustor. Most advanced designs rely on a method of pre-mixing the fuel/air before it enters the combustion burner area. In the TAPS design, air from the high-pressure compressor is directed into the combustor through two high-energy swirlers adjacent to the fuel nozzles. This swirl creates a more thorough and leaner mix of fuel and air, which burns at lower temperatures than in previous gas turbine engine designs. Most of the NOX is formed by the reaction of oxygen and nitrogen at high temperatures. The NOX levels are higher if the burning fuel/air mixture stays at high temperatures for a longer time. Newly designed combustors also produce lower levels of carbon monoxide and unburned hydrocarbons. The increases in gas turbine engine component efficiencies have resulted in fewer emissions from gas turbine engines.

**Question: 7-1**

The \_\_\_\_\_ collects the exhaust gases discharged from the turbine section and gradually converts them into a solid flow of gases.

**Question: 7-5**

The greatest perceived level of noise from a turbine engine is generated where?

**Question: 7-2**

Through the use of a converging nozzle, the exhaust gases \_\_\_\_\_ in velocity before they are discharged from the exhaust nozzle.

**Question: 7-6**

Most turbine engine emissions research centers around the \_\_\_\_\_ section of the engine.

**Question: 7-3**

If an exhaust nozzle opening is too big, thrust is being wasted. If it is too little, the flow is \_\_\_\_\_ in the other components of the engine.

**Question: 7-7**

What is the purpose of an exhaust cone behind the turbine section?

**Question: 7-4**

Into what two categories can thrust reverser's be divided?

**Question: 7-8**

What type of exhaust duct would you find on a turboshaft engine?

## ANSWERS

*Answer: 7-1*  
exhaust cone.

*Answer: 7-5*  
Behind the engine at a distance of approximately 10  
nozzle diameters.

*Answer: 7-2*  
increase.

*Answer: 7-6*  
combustion.

*Answer: 7-3*  
choked.

*Answer: 7-7*  
Reduces the turbulence of the air exiting the engine,  
thus limiting drag.

*Answer: 7-4*  
mechanical blockage.  
aerodynamic blockage.

*Answer: 7-8*  
A divergent duct.



PART-66 SYLLABUS LEVELS  
 CERTIFICATION CATEGORY → A1 B1

**Sub-Module 08**  
**BEARINGS AND SEALS**

Knowledge Requirements

*15.8 - Bearings and Seals*

Constructional features and principles of operation.

CERTIFICATION CATEGORY →	A1	B1
	-	2

**Level 2**

A general knowledge of the theoretical and practical aspects of the subject and an ability to apply that knowledge.

*Objectives:*

- (a) The applicant should be able to understand the theoretical fundamentals of the subject.
- (b) The applicant should be able to give a general description of the subject using, as appropriate, typical examples.
- (c) The applicant should be able to use mathematical formula in conjunction with physical laws describing the subject.
- (d) The applicant should be able to read and understand sketches, drawings and schematics describing the subject.
- (e) The applicant should be able to apply his knowledge in a practical manner using detailed procedures.

BEARINGS AND SEALS

## BEARINGS AND SEALS

The main bearings of a turbine engine have the critical function of supporting the main engine rotor. The number of bearings necessary for proper engine support is, for the most part, determined by the length and weight of the engine rotor. The length and weight are directly affected by the type of compressor used in the engine. Naturally, a two-spool compressor requires more bearing support. **Figure 8-1** depicts the three bearing locations on a typical engine.

The minimum number of bearings required to support one shaft is one deep groove ball bearing (thrust and radial loads) and one straight roller bearing (radial load only). Sometimes, it is necessary to use more than one roller bearing if the shaft is subject to vibration or its length is excessive. The gas turbine rotors are supported by ball and roller bearings, which are antifriction bearings. (**Figure 8-2**)

Many newer engines use hydraulic bearings, in which the outside race is surrounded by a thin film of oil. This reduces vibrations transmitted to the engine. In general, antifriction bearings are preferred largely because they:

- Offer little rotational resistance,
- Facilitate precision alignment of rotating elements,
- Are relatively inexpensive,
- Are easily replaced,
- Withstand high momentary overloads,
- Are simple to cool, lubricate, and maintain,
- Accommodate both radial and axial loads, and
- Are relatively resistant to elevated temperatures.

The main disadvantages are their vulnerability to foreign matter and tendency to fail without appreciable warning. Usually the ball bearings are positioned on the compressor or turbine shaft so that they can absorb any axial (thrust) loads or radial loads. Because the roller bearings present a larger working surface, they are better equipped to support radial loads than thrust loads. Therefore, they are used primarily for this purpose. A typical ball or roller bearing assembly includes a bearing support housing, which must be strongly constructed and supported in order to carry the radial and axial loads of the rapidly rotating rotor.

The bearing housing usually contains oil seals to prevent the oil leaking from its normal path of flow. It also delivers the oil to the bearing for its lubrication, usually through spray nozzles. The oil seals may be the labyrinth or thread (helical) type. These seals also may be pressurized to minimize oil leaking along the compressor shaft. The labyrinth seal is usually pressurized, but the helical seal depends solely on reverse threading to stop oil leakage. These two types of seals are very similar, differing only in thread size and the fact that the labyrinth seal is pressurized. **Figure 8-3** shows a main bearing from a Solar T-62T engine.

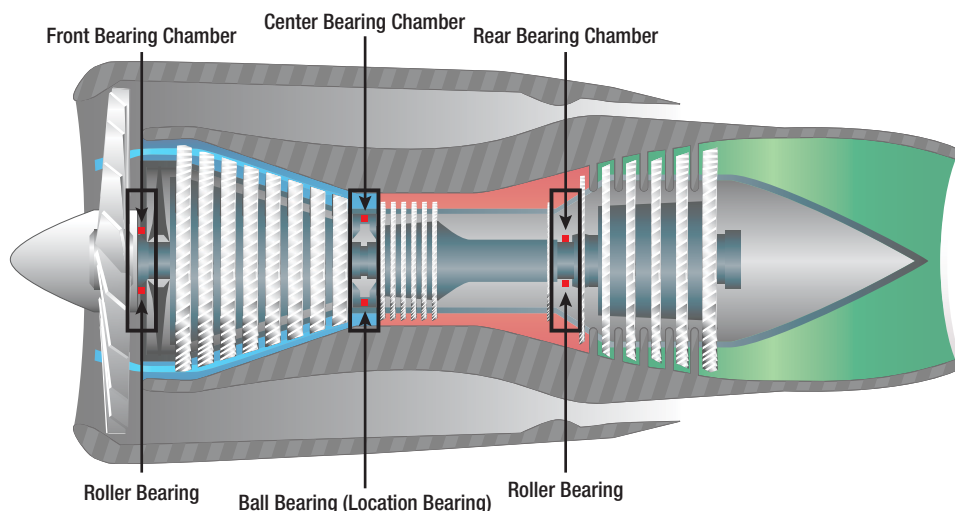

Figure 8-1. Bearing locations on a typical turbine engine, forward and aft of the compressor, and forward of the turbine section.

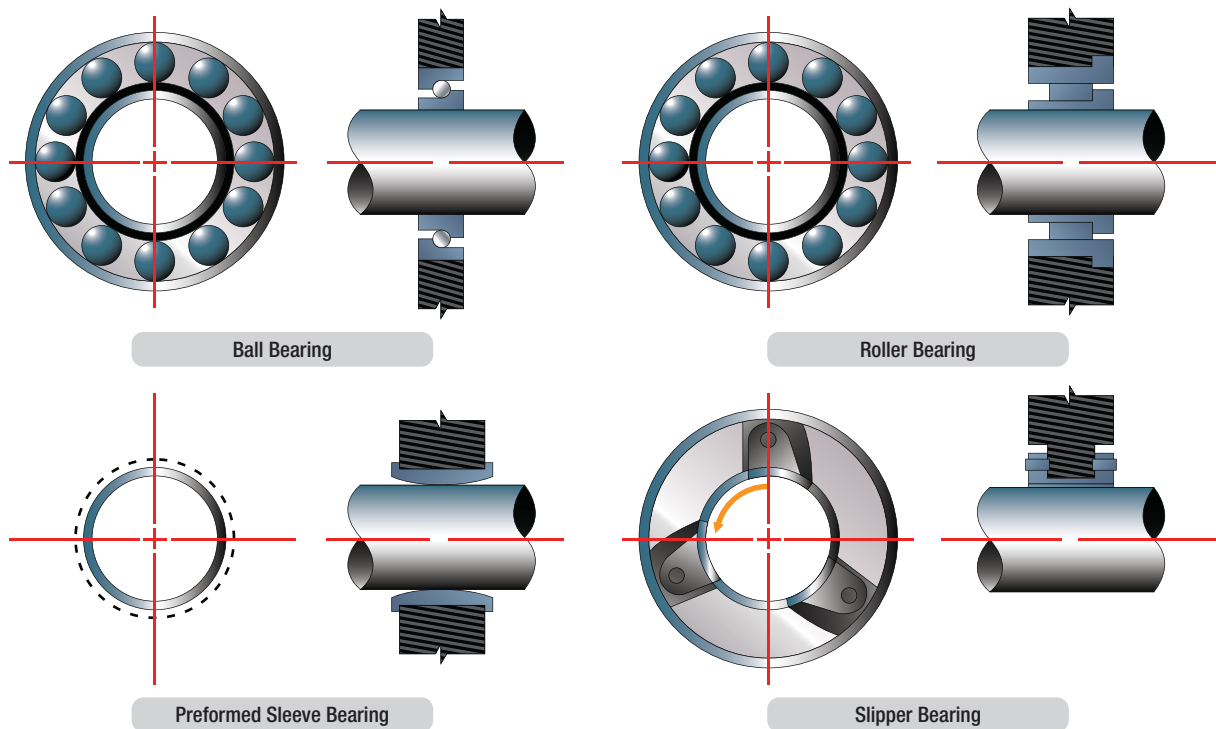

Figure 8-2. Types of main bearing used for gas turbine rotor support.

The ball or roller bearing is fitted into the bearing housing and may have a self-aligning feature. If a bearing is self-aligning, it is usually seated in a spherical ring. This allows the shaft a certain amount of radial movement without transmitting stress to the bearing inner race.

The bearing surface is usually provided by a machined journal on the appropriate shaft. The bearing is usually locked in position by a steel snap ring or other suitable locking device. The rotor shaft also provides the matching surface for the oil seals in the bearing housing. These machined surfaces are called lands and fit in rather close to the oil seal.

Another type of oil seal used on some of the later engines is the carbon seal. These seals are usually spring loaded and are similar in material and application to the carbon brushes used in electrical motors. Carbon seals rest against a surface provided to create a sealed bearing cavity or void; thus, the oil is prevented from leaking out along the shaft into the compressor airflow or the turbine section. (*Figure 8-4 and Figure 8-5*)



Figure 8-3. A turbine engine main rotor bearing.



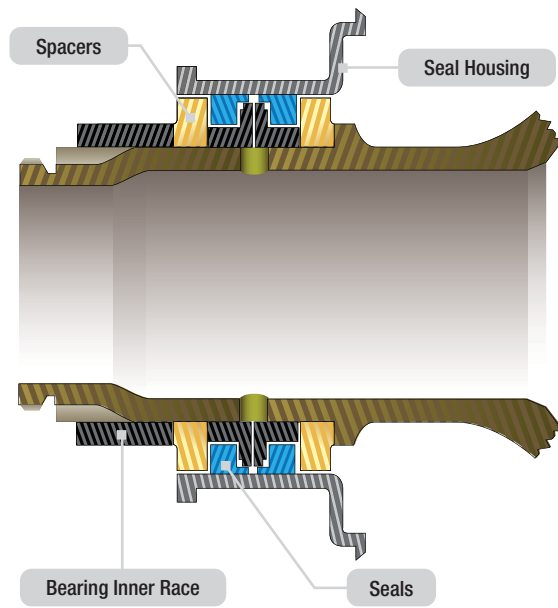

Figure 8-4. A carbon oil seal.



Figure 8-5. Typical face and circumferential seal ring configuration utilizing mechanical carbons.

**Question: 8-1**

A bearing used to support a gas turbine rotor that is surrounded by a thin film of oil to reduce vibration is called a \_\_\_\_\_ bearing.

**Question: 8-4**

What determines the number of bearings required to support the main rotor of a turbine engine?

**Question: 8-2**

Carbon seals in a gas turbine engine are usually \_\_\_\_\_ loaded.

**Question: 8-5**

What is the most significant maintenance concern regarding bearings?

**Question: 8-3**

What loads are supported by a deep groove ball bearing?

## ANSWERS

*Answer:* 8-1  
hydraulic.

*Answer:* 8-4  
The length and weight of the main rotor shaft.

*Answer:* 8-2  
spring.

*Answer:* 8-5  
Ingestion of foreign matter and dirt.

*Answer:* 8-3  
Both thrust and radial loads.



PART-66 SYLLABUS LEVELS  
 CERTIFICATION CATEGORY → **A1** **B1**

**Sub-Module 09**  
**LUBRICANTS AND FUELS**  
 Knowledge Requirements

*15.10 – Lubricants and Fuels*

- Properties and specifications;
- Fuel additives;
- Safety precautions.

CERTIFICATION CATEGORY →	A1	B1
	<b>1</b>	<b>2</b>

**Level 1**

A familiarization with the principal elements of the subject.

*Objectives:*

- (a) The applicant should be familiar with the basic elements of the subject.
- (b) The applicant should be able to give a simple description of the whole subject, using common words and examples.
- (c) The applicant should be able to use typical terms.

**Level 2**

A general knowledge of the theoretical and practical aspects of the subject and an ability to apply that knowledge.

*Objectives:*

- (a) The applicant should be able to understand the theoretical fundamentals of the subject.
- (b) The applicant should be able to give a general description of the subject using, as appropriate, typical examples.
- (c) The applicant should be able to use mathematical formula in conjunction with physical laws describing the subject.
- (d) The applicant should be able to read and understand sketches, drawings and schematics describing the subject.
- (e) The applicant should be able to apply his knowledge in a practical manner using detailed procedures.

---

## LUBRICANTS AND FUELS

### REQUIREMENTS FOR TURBINE ENGINE LUBRICANTS

There are many requirements for turbine engine lubricating oils. Due to the absence of reciprocating motion and the presence of ball and roller bearings (antifriction bearings), the turbine engine uses a less viscous lubricant. Gas turbine engine oil must have a high viscosity for good load-carrying ability but must also be of sufficiently low viscosity to provide good flowability. It must also be of low volatility to prevent loss by evaporation at the high altitudes at which the engines operate. In addition, the oil should not foam and should be essentially nondestructive to natural or synthetic rubber seals in the lubricating system. Also, with high-speed antifriction bearings, the formation of carbons or varnishes must be held to a minimum. Synthetic oil for turbine engines are usually supplied in sealed one-quart cans.

The many requirements for lubricating oils are met in the synthetic oils developed specifically for turbine engines. Synthetic oil has two principal advantages over petroleum oil. It has a lower tendency to deposit lacquer and coke (solids left after solvents have been evaporated) because it does not evaporate the solvents from the oil at high temperature.

Oil grades used in some turbine engines normally contain thermal and oxidation preventives, load-carrying additives, and substances that lower the pour point in addition to synthetic chemical-base materials. MIL-L-7808, which is a military specification for turbine oil, was type I turbine oil. Turbine synthetic oil has a viscosity of around 5 to 5.5 centistokes at 210° F that is approved against the military specification MIL-PRF-23699F. This oil is referred to as type II turbine oil.

Most turbine oils meet this type II specification and are made with the following characteristics:

1. Vapor phase deposits—carbon deposits formed from oil mist and vapor contact with hot engine surfaces.
2. Load-carrying ability—provides for heavy loads on the bearing systems of turbine engines.
3. Cleanliness—minimum formation of sludge deposits during severe operation.

4. Bulk stability—resistance to physical or chemical change resulting from oxidation. Permits long periods of serve operation without significant increase in viscosity or total acidity, the main indicators of oxidation.
5. Compatibility—most turbine oil is compatible with other oils that meet the same military specification. But, most engine manufacturers do not recommend the indiscriminate mixing of approved oil brands and this is not a generally accepted practice.
6. Seal Wear—essential for the life of engines with carbon seals that lubricant properties prevent wear of the carbon at the carbon seal face.

### TURBINE OIL HEALTH AND SAFETY PRECAUTIONS

Under normal conditions, the use of turbine oil presents a low health risk for humans. Although each person reacts somewhat differently to exposure, contact with liquids, vapors, and mist of turbine oil should be minimized. Information on established limits on exposure to turbine oil can generally be found in the material safety data sheets (MSDS). Prolonged breathing of hydrocarbon vapor concentrations in excess of the prescribed limits may result in lightheadedness, dizziness, and nausea. If turbine oil is ingested, call a doctor immediately; identify the product and how much was ingested. Because of the risk of ingestion, petroleum products should never be siphoned by mouth.

Prolonged or repeated contact of turbine oil with the skin can cause irritation and dermatitis. In case of skin contact, wash the skin thoroughly with soap and warm water. Promptly remove oil-soaked clothing and wash. If turbine oil contacts the eyes, flush the eyes with fresh water until the irritation subsides. Protective clothing, gloves, and eye protection should be used when handling turbine oil. During operation, it is possible for the oil to be subjected to very high temperatures that can break down the oil and produce a product of unknown toxicity. If this happens, all precautions to avoid explosive should be taken. It can also have a tendency to blister, discolor, or remove paint when spilled. Painted surfaces should be wiped clean with a petroleum solvent after spillage.

## TURBINE ENGINE FUELS

Aircraft with turbine engines use a type of fuel different from that of reciprocating aircraft engines. Commonly known as jet fuel, turbine engine fuel is designed for use in turbine engines and should never be mixed with aviation gasoline or introduced into the fuel system of a reciprocating aircraft engine fuel system. The characteristics of turbine engine fuels are significantly different from those of AVGAS. Turbine engine fuels are hydrocarbon compounds of higher viscosity with much lower volatility and higher boiling points than gasoline. In the distillation process from crude oil, the kerosene cut from which jet fuel is made

condenses at a higher temperature than the naphtha or gasoline cuts. The hydrocarbon molecules of turbine engine fuels are composed of more carbon than are in AVGAS. (Figure 9-1)

As can be seen, there are significant differences between turbine engine fuel and ordinary AVGAS. Turbine engine fuels sustain a continuous flame inside the engine. They typically have a higher sulfur content than gasoline, and various inhibitors are commonly added them. Used to control corrosion, oxidation, ice, and microbial and bacterial growth, these additives often are already in the fuel when it arrives at the airport for use.

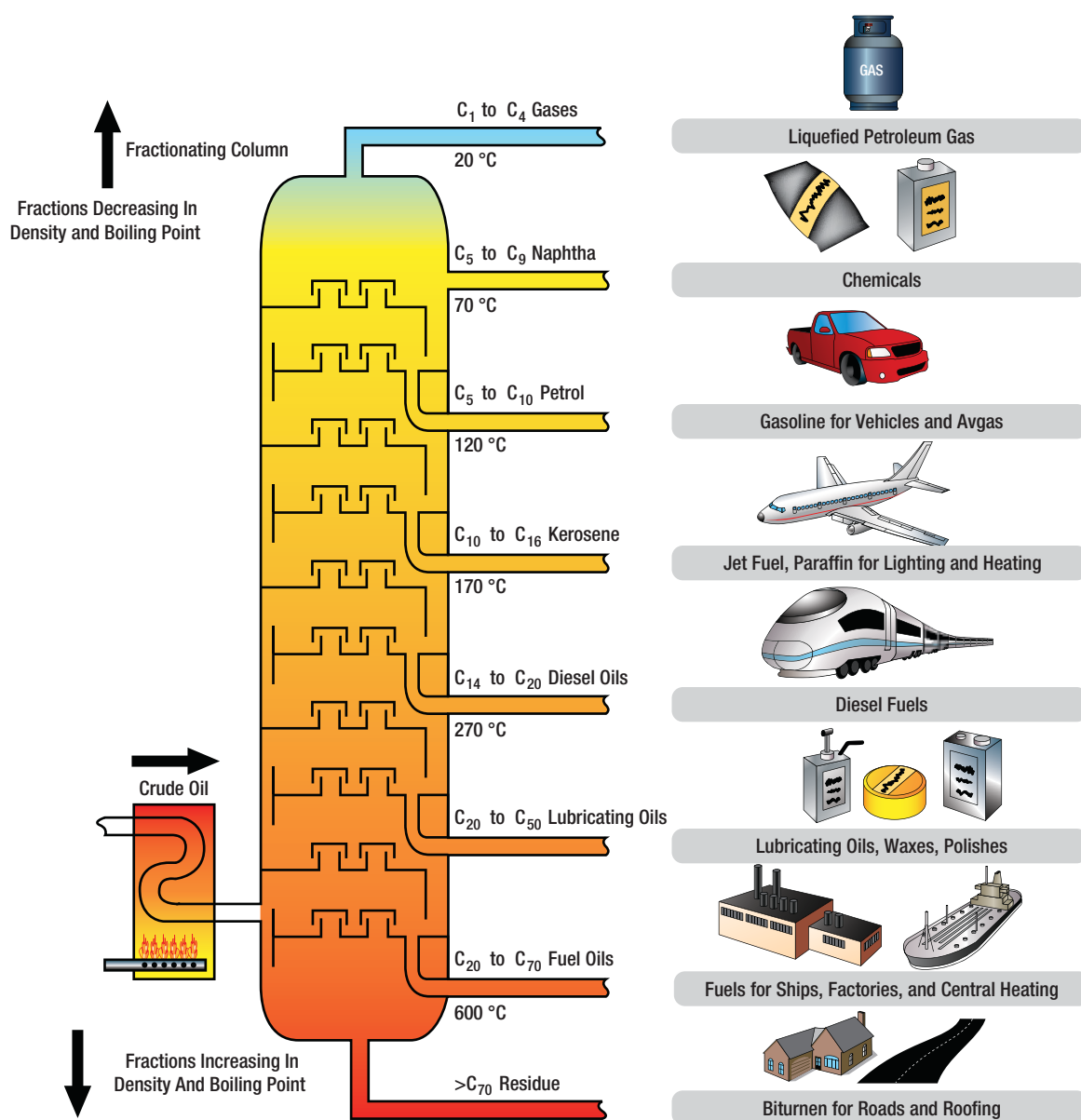

Figure 9-1. Petroleum products are produced by distillation. Various fractions condense and are collected at different temperatures that correspond to the height of collection in the distillation tower. As can be seen, there are significant differences between turbine engine fuel and ordinary AVGAS.

## TURBINE FUEL VOLATILITY

The choice of turbine engine fuel reflects consideration of conflicting factors. While it is desirable to use a fuel that is low in volatility to resist vapor lock and evaporation while in the aircraft's fuel tanks, turbine engine aircraft operate in cold environments. Turbine engines must start readily, and be able to restart while in flight. Fuel with high volatility makes this easier. AVGAS has a relatively low maximum vapor pressure compared to automotive gasoline, only 7 psi. But the vapor pressure of Jet A is only 0.125 psi at standard atmospheric conditions. Jet B, a blend of Jet A and gasoline, has higher volatility with a vapor pressure between 2 and 3 psi.

## TURBINE ENGINE FUEL TYPES

Three basic turbine engine fuel types are available worldwide, although some countries have their own unique fuels. The first is Jet A. It is the most common turbine engine fuel available in the continental United States. Globally, Jet A-1 is the most popular. Both Jet A and Jet A-1 are fractionally distilled in the kerosene range. They have low volatility and low vapor pressure. Flash points range between 110 °F and 150 °F. Jet A freezes at -40 °F and Jet A-1 freezes at -52.6 °F. Most engine operations manuals permit the use of either Jet A or Jet A-1.

The third basic type of turbine engine fuel available is Jet B. It is a wide-cut fuel that is basically a blend of kerosene and gasoline. Its volatility and vapor pressure reflect this and fall between Jet A and AVGAS. Jet B is primarily available in Alaska and Canada due to its low freezing point of approximately -58 °F, and its higher volatility yields better cold weather performance.

## FUEL IDENTIFICATION

Aircraft and engine manufacturers designate approved fuels for each aircraft and engine. Consult manufacturer data and use only those fuel specified therein. The existence of more than one fuel makes it imperative that fuel be positively identified and never introduced into a fuel system that is not designed for it. The use of dyes in fuel helps aviators monitor fuel type. AVGAS for reciprocating engines is dyed various colors for use in different parts of the world. Jet fuel is not dyed. The color of fuel may be referred to in older maintenance manuals. All grades of jet fuel are colorless or straw colored. This distinguishes them from AVGAS of any kind that contains dye of some color. Do not release an aircraft for flight with unknown fuel onboard.

Identifying fuel and ensuring the correct fuel is delivered into storage tanks, fuel trucks, and aircraft fuel tanks is a process aided by labeling. Decals and markings using the same colors as the AVGAS colors are used. Delivery trucks and hoses are marked as are aircraft tank fuel caps and fill areas. Jet fuel fill hose nozzles are sized too large to fit into an AVGAS tank fill opening. *Figure 9-2* shows examples of color-coded fuel labeling.

## PURITY

The use of filters in the various stages of transfer and storage of jet fuel removes most foreign sediment from the fuel. Once in the aircraft fuel tanks, debris should settle into the fuel tank drain sumps to be removed before flight. Filters and strainers in the aircraft fuel system can successfully capture any remaining sediment.

The purity of aviation fuel is compromised most often by water. Water also settles into the sumps given enough time. However, water is not removed by the aircraft's filters and strainers as easily as solid particles. It can enter the fuel even when the aircraft is parked on the ramp with the fuel caps in place. Air in the tank vapor space above the liquid fuel contains water vapor. Temperature fluctuations cause the water vapor to condense on the inner surface of the tanks and settle into the liquid fuel. Eventually, this settles to the sump, but some can remain in the fuel when the aircraft is to be flown.

Proper procedure for minimizing water entering aircraft fuel is to fill the aircraft fuel tanks immediately after each flight. This minimizes the size of the vapor space above the liquid fuel and the amount of air and associated water vapor present in the tank.

If water is entrained or dissolved in the fuel, it cannot be removed by draining the sump(s) before flight. However, there may be enough water for icing to be a concern. As the aircraft climbs and fuel is drawn out of the tanks, the fuel supply cools. Entrained and dissolved water in the fuel is forced out of solution and becomes free water. If cool enough, ice crystals form rather than liquid water. These can clog filters and disrupt fuel flow to the engines. Both AVGAS and jet fuel have this type of water impurity issue leading to icing that must be monitored and treated.











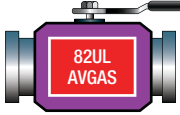

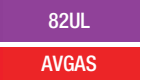

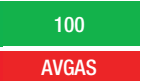

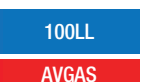
Fuel Type and Grade	Color of Fuel	Equipment Control Color	Pipe Banding and Marking	Refueler Decal
AVGAS 82UL	Purple			
AVGAS 100	Green			
AVGAS 100LL	Blue			
JET A	Colorless or Straw			
JET A-1	Colorless or Straw			
JET B	Colorless or Straw			

Figure 9-2. Color coded labeling and markings used on fueling equipment.

Fuel anti-ice additives can be added to the bulk fuel and also directly into the aircraft fuel tank, usually during refueling. These are basically diethylene glycol solutions that work as antifreeze. They dissolve in free water as it comes out of the fuel and lower its freezing point. (Figure 9-3)

### MICROBES

Purity issues related to turbine engine fuels are unique. While AVGAS experiences similar issues of solid particle contamination and icing concerns, the presence of water and fuel-consuming microbes is more prominent in jet fuel, which has different molecular structure and retains water in two principal ways. Some water is dissolved into the fuel. Other water is entrained in the fuel, which is more viscous than AVGAS. The greater presence of water in jet fuel allows microbes to assemble, grow, and live on the fuel.

Since turbine engine fuels always contain water, microbial contamination is always a threat. The large tanks of many turbine engine aircraft have numerous areas where water can settle and microbes can flourish.



Figure 9-3. Fuel anti-icing products, such as Prist®, act as antifreeze for any free water in aircraft fuel. They dissolve in water and lower its freezing point to prevent ice crystals from disrupting fuel flow.

Areas between the fuel tank and any water that may come to rest in the bottom of the tanks is where the microbes thrive. These microorganisms form a bio-film



that can clog filters, corrode tank coatings, and degrade the fuel. They can be controlled somewhat with the addition of biocides to the fuel. (*Figure 9-4*) Anti-ice additives are also known to inhibit bacterial growth.

Since the microbes are sustained by fuel and water, best practices must be followed to keep the water in fuel to a minimum. Avoid having fuel in a storage tank for a prolonged period of time on or off the aircraft. Drain sumps and monitor the fuel for settled water. Investigate all incidents of water discovered in the fuel. In addition to water in jet fuel supporting the growth of microorganisms, it also poses a threat of icing. Follow the manufacturer's instructions for fuel handling procedures and fuel system maintenance.



Figure 9-4. Biocides, such as these, are often added to jet fuel to kill microbes that live on hydrocarbons.

*Question: 9-1*

Turbine engine fuel must be of low volatility to prevent loss by \_\_\_\_\_ at the high altitudes at which the engines operate.

*Question: 9-5*

What are the common health related symptoms of overexposure to turbine oils and oil mists?

*Question: 9-2*

Turbine engine has a \_\_\_\_\_ boiling point than gasoline.

*Question: 9-6*

Low viscosity oils provide good \_\_\_\_\_ while high viscosity oils provide \_\_\_\_\_. Which characteristic is most important for turbine engines?

*Question: 9-3*

AVGAS for reciprocating engines is dyed various colors for use in different parts of the world, however jet fuel is \_\_\_\_\_ dyed.

*Question: 9-7*

In what two ways are microbes prevented from developing in jet fuel?

*Question: 9-4*

Since turbine engine fuels always contain water, \_\_\_\_\_ contamination is always a threat.

*Question: 9-8*

What is the most common and difficult to control contaminant in Jet Fuel?

## ANSWERS

*Answer:* 9-1  
evaporation.

*Answer:* 9-5  
Light headedness, dizziness, nausea.

*Answer:* 9-2  
higher.

*Answer:* 9-6  
Flowability, load carrying capacity; both are equally important.

*Answer:* 9-3  
not.

*Answer:* 9-7  
Keeping water out of the fuel tanks; and using a biocide fuel additive.

*Answer:* 9-4  
microbial.

*Answer:* 9-8  
Water.



PART-66 SYLLABUS **LEVELS**  
 CERTIFICATION CATEGORY → **A1** **B1**

**Sub-Module 10**  
**LUBRICATION SYSTEMS**  
 Knowledge Requirements

*15.10 – Lubrication Systems*  
 System operation / lay-out and components.

	A1	B1
1		
2		

**Level 1**  
 A familiarization with the principal elements of the subject.

- Objectives:*
- (a) The applicant should be familiar with the basic elements of the subject.
  - (b) The applicant should be able to give a simple description of the whole subject, using common words and examples.
  - (c) The applicant should be able to use typical terms.

**Level 2**  
 A general knowledge of the theoretical and practical aspects of the subject and an ability to apply that knowledge.

- Objectives:*
- (a) The applicant should be able to understand the theoretical fundamentals of the subject.
  - (b) The applicant should be able to give a general description of the subject using, as appropriate, typical examples.
  - (c) The applicant should be able to use mathematical formula in conjunction with physical laws describing the subject.
  - (d) The applicant should be able to read and understand sketches, drawings and schematics describing the subject.
  - (e) The applicant should be able to apply his knowledge in a practical manner using detailed procedures.

---

## TURBINE ENGINE LUBRICATION SYSTEMS

Both wet- and dry-sump lubrication systems are used in gas turbine engines. Wet-sump engines store the lubricating oil in the engine proper, while dry-sump engines utilize an external tank mounted on the engine or somewhere in the aircraft structure near the engine, similar to reciprocating piston engines mentioned earlier.

Turbine engine's oil systems can also be classified as a pressure relief system that maintains a somewhat constant pressure: the full flow type of system, in which the pressure varies with engine speed, and the total loss system, used in engines that are for short duration operation (target drones, missiles, etc.). The most widely used system is the pressure relief system with the full flow used mostly on large fan type engines. One of the main functions of the oil system in turbine engines is cooling the bearings by carrying the heat away from the bearing by circulating oil around the bearing.

The exhaust turbine bearing is the most critical lubricating point in a gas turbine engine because of the high temperature normally present. In some engines, air cooling is used in addition to oil cooling the bearing, which supports the turbine. Air cooling, referred to as secondary air flow, is cooling air provide by bleed air from the early stages of the compressor. This internal air flow has many uses on the inside of the engine. It is used to cool turbine disk, vanes, and blades. Also, some turbine wheels may have bleed air flowing over the turbine disk, which reduces heat radiation to the bearing surface. Bearing cavities sometimes use compressor air to aid in cooling the turbine bearing. This bleed air is usually bled off a compressor stage at a point where air has enough pressure but has not yet become too warm (as the air is compressed, it becomes heated).

The use of cooling air substantially reduces the quantity of oil necessary to provide adequate cooling of the bearings. Since cooling is a major function of the oil in turbine engines, the lubricating oil for bearing cooling normally requires an oil cooler. When one is required, usually a greater quantity of oil is necessary to provide for circulation between the cooler and engine. To ensure proper temperature, oil is routed through either air-cooled and/or fuel-cooled oil coolers. This system is used to also heat (regulate) the fuel to prevent ice in the fuel.

### TURBINE LUBRICATION SYSTEM COMPONENTS

The following component descriptions include most found in the various turbine lubrication systems. However, since engine oil systems vary somewhat according to engine model and manufacturer, not all of these components are necessarily found in any one system.

#### OIL TANK

Although the dry-sump systems use an oil tank that contains most of the oil supply, a small sump is usually included on the engine to hold a small supply of oil. It usually contains the oil pump, the scavenge and pressure inlet strainers, scavenge return connection, pressure outlet ports, an oil filter, and mounting bosses for the oil pressure gauge and temperature bulb connections.

A view of a typical oil tank is shown in *Figure 10-1*. It is designed to furnish a constant supply of oil to the engine during any aircraft attitude. This is done by a swivel outlet assembly mounted inside the tank, a horizontal baffle mounted in the center of the tank, two flapper check valves mounted on the baffle, and a positive vent system.

The swivel outlet fitting is controlled by a weighted end that is free to swing below the baffle. The flapper valves in the baffle are normally open; they close only when the oil in the bottom of the tank tends to rush to the top of the tank during decelerations. This traps the oil in the bottom of the tank where it is picked up by the swivel fitting. A sump drain is located in the bottom of the tank. The vent system inside the tank is so arranged that the airspace is vented at all times even though oil may be forced to the top of the tank by deceleration of the aircraft.

All oil tanks are provided with expansion space. This allows expansion of the oil after heat is absorbed from the bearings and gears and after the oil foams as a result of circulating through the system. Some tanks also incorporate a deaerator tray for separating air from the oil returned to the top of the tank by the scavenger system. Usually these deaerators are the can type in which oil enters at a tangent. The air released is carried out through the vent system in the top of the tank. In most oil tanks, a pressure buildup is desired within the tank to ensure a positive flow of oil to the oil pump inlet. This pressure buildup is made possible by running the

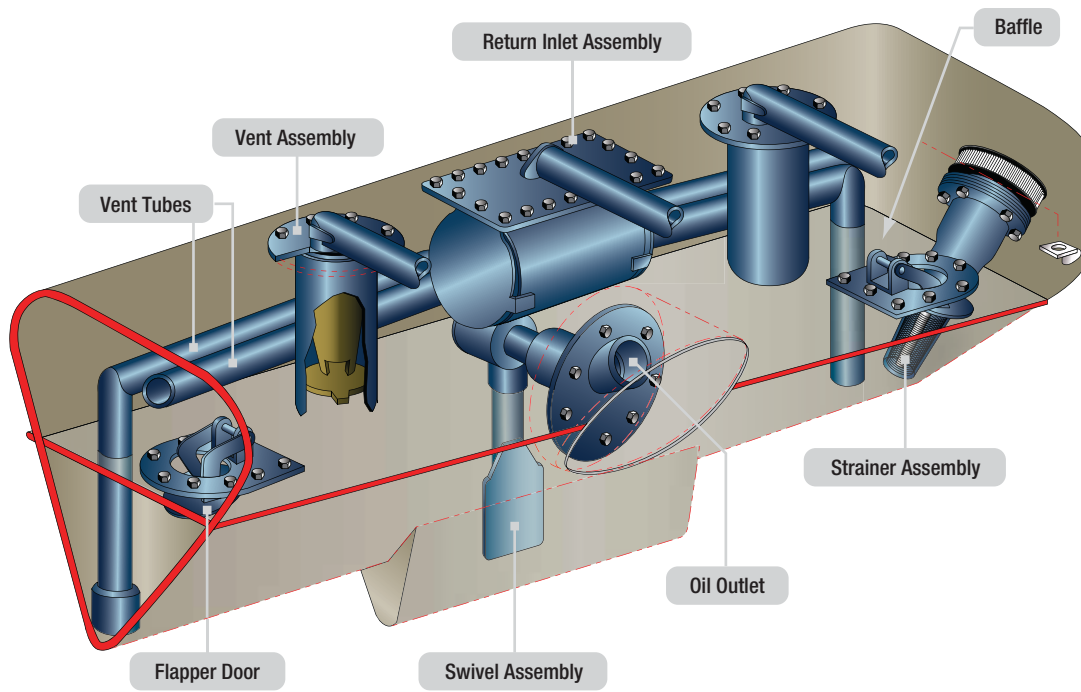

Figure 10-1. Oil tank.

vent line through an adjustable check relief valve. The check relief valve is usually set to relieve at about 4 psi, keeping positive pressure on the oil pump inlet. If the air temperature is abnormally low, the oil may be changed to a lighter grade. Some engines may provide for the installation of an immersion-type oil heater.

## OIL PUMP

The oil pump is designed to supply oil under pressure to the parts of the engine that require lubrication, then circulate the oil through coolers as needed, and return the oil to the oil tank. Many oil pumps consist of not only a pressure supply element, but also scavenge elements, such as in a dry-sump system. However, there are some oil pumps that serve a single function; that is, they either supply or scavenge the oil. These pump elements can be located separate from each other and driven by different shafts from the engine. The numbers of pumping elements (two gears that pump oil), pressure and scavenge, depend largely on the type and model of the engine. Several scavenge oil pump elements can be used to accommodate the larger capacity of oil and air mix. The scavenge elements have a greater pumping capacity than the pressure element to prevent oil from collecting in the bearing sumps of the engine.

The pumps may be one of several types, each type having certain advantages and limitations. The two most common oil pumps are the gear and gerotor, with the

gear-type being the most commonly used. Each of these pumps has several possible configurations.

The gear-type oil pump has only two elements: one for pressure oil and one for scavenging. (*Figure 10-2*) However, some types of pumps may have several elements: one or more elements for pressure and two or more for scavenging. The clearances between the gear teeth and the sides of the pump wall and plate are critical to maintain the correct output of the pump.

A regulating (relief) valve in the discharge side of the pump limits the output pressure of the pump by bypassing oil to the pump inlet when the outlet pressure exceeds a predetermined limit. (*Figure 10-2*) The regulating valve can be adjusted, if needed, to bring the oil pressure within limits. Also shown is the shaft shear section that causes the shaft to shear if the pump gears should seize up and not turn.

The gerotor pump, like the gear pump, usually contains a single element for oil pressure and several elements for scavenging oil. Each of the elements, pressure and scavenge, are almost identical in shape; however, the capacity of the elements can be controlled by varying the size of the gerotor elements. For example, the pressure element may have a pumping capacity of 3.1 gallon per minute (gpm) as compared to 4.25 gpm capacity for the scavenge elements. Consequently, the pressure element

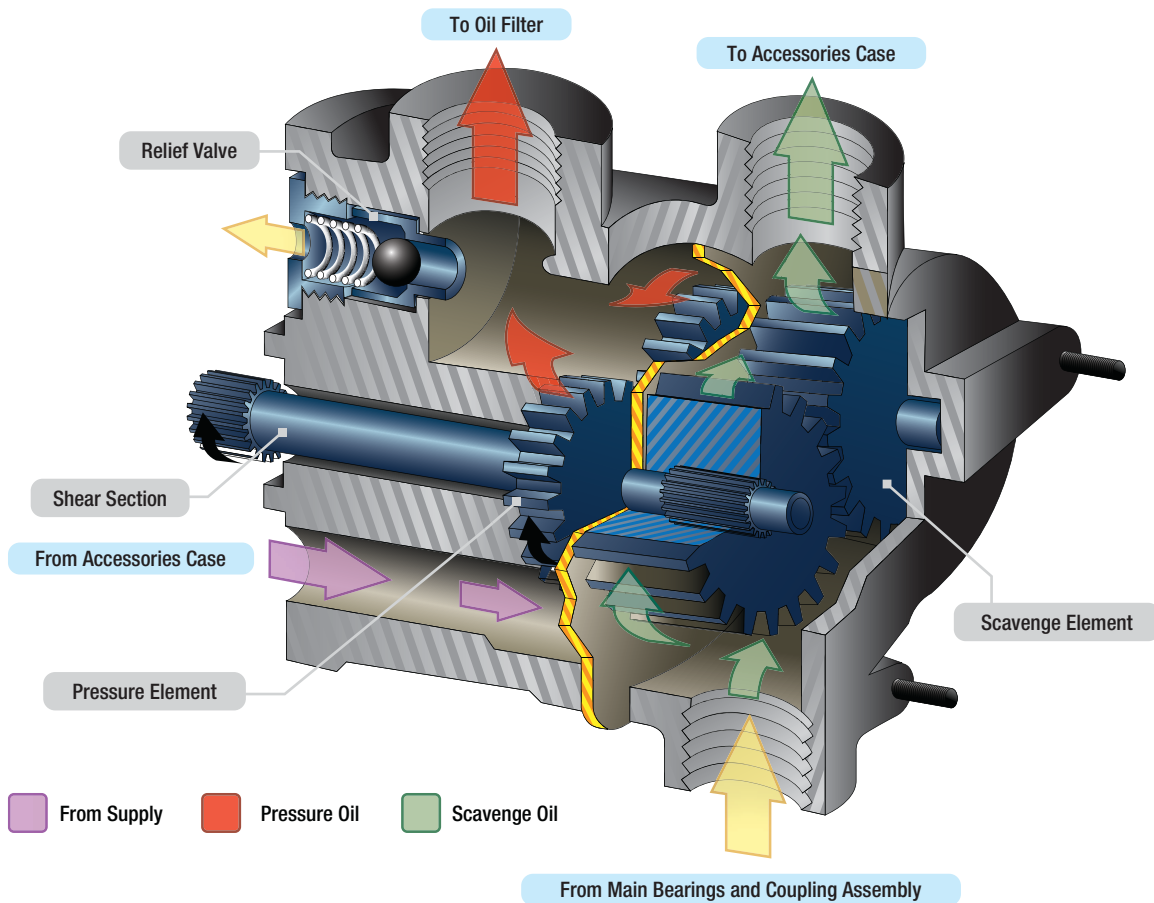

Figure 10-2. Cutaway view of gear oil pump.

is smaller since the elements are all driven by a common shaft. The pressure is determined by engine rpm with a minimum pressure at idling speed and maximum pressure at intermediate and maximum engine speeds.

A typical set of gerotor pumping elements is shown in *Figure 10-3*. Each set of gerotors is separated by a steel plate, making each set an individual pumping unit consisting of an inner and an outer element. The small star-shaped inner element has external lobes that fit within and are matched with the outer element that has internal lobes. The small element fits on and is keyed to the pump shaft and acts as a drive for the outer free-turning element. The outer element fits within a steel plate having an eccentric bore. In one engine model, the oil pump has four elements: one for oil feed and three for scavenge. In some other models, pumps have six elements: one for feed and five for scavenge. In each case, the oil flows as long as the engine shaft is turning.

### TURBINE OIL FILTERS

Filters are an important part of the lubrication system because they remove foreign particles that may be in the

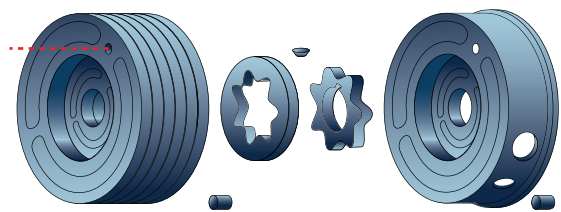

Figure 10-3. Typical gerotor pumping elements.

oil. This is particularly important in gas turbines as very high engine speeds are attained; the antifriction types of ball and roller bearings would become damaged quite rapidly if lubricated with contaminated oil. Also, there are usually numerous drilled or core passages leading to various points of lubrication. Since these passages are usually rather small, they are easily clogged.

There are several types and locations of filters used for filtering the turbine lubricating oil. The filtering elements come in a variety of configurations and mesh sizes. Mesh sizes are measured in microns, which is a linear measurement equal to one millionth of a meter (a very small opening).

A main oil strainer filter element is shown in *Figure 10-4*. The filtering element interior is made of varying materials including paper and metal mesh. (*Figure 10-5*) Oil normally flows through the filter element from the outside into the filter body. One type of oil filter uses a replaceable laminated paper element, while others use a very fine stainless steel metal mesh of about 25–35 microns.

Most filters are located close to the pressure pump and consist of a filter body or housing, filter element, a bypass valve, and a check valve. The filter bypass valve prevents the oil flow from being stopped if the filter element becomes clogged. The bypass valve opens whenever a certain pressure is reached.

If this occurs, the filtering action is lost, allowing unfiltered oil to be pumped to the bearings. However, this prevents the bearings from receiving no oil at all. In the bypass mode, many engines have a mechanical indicator that pops out to indicate the filter is in the bypass mode. This indication is visual and can only be seen by inspecting the engine directly. An antidrain check valve is incorporated into the assembly to prevent the oil in the tank from draining down into the engine sumps when the engine is not operating. This check valve is normally spring loaded closed with 4 to 6 psi needed to open it.

The filters generally discussed are used as main oil filters; that is, they strain the oil as it leaves the pump before being piped to the various points of lubrication. In addition to the main oil filters, there are also secondary filters located throughout the system for various purposes. For instance, there may be a finger screen filter that is sometimes used for straining scavenged oil. These screens tend to be large mesh screens that trap larger contaminants. Also, there are fine-mesh screens called last chance filters for straining the oil just before it passes from the spray nozzles onto the bearing surfaces. (*Figure 10-6*) These filters are located at each bearing and help screen out contaminants that could plug the oil spray nozzle.

## OIL PRESSURE REGULATING VALVE

Most turbine engine oil systems are the pressure regulating type system that keeps the pressure fairly constant. An oil pressure regulating valve is included in the oil system on the pressure side of the pressure pump.

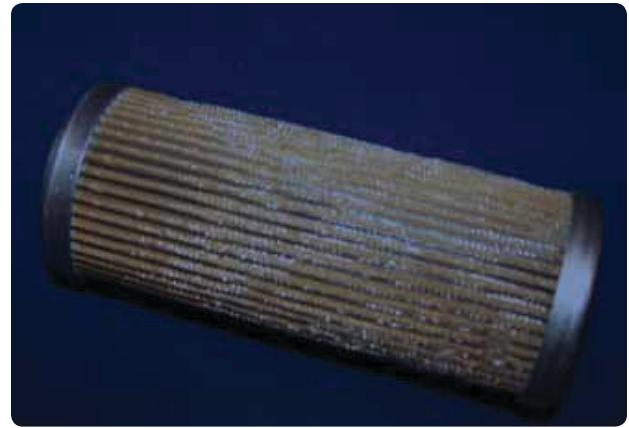

Figure 10-4. Turbine oil filter element.



Figure 10-5. Turbine oil filter paper element.



Figure 10-6. Last-chance filter before spray nozzle.



A regulating valve system controls the systems pressure to a limited pressure within the system. It is more of a regulating valve than a relief valve because it keeps the pressure in the system within certain limits other than only opening when the absolute maximum pressure of the system is exceeded.

The regulating valve *Figure 10-7* has a valve held against a seat by a spring. By adjusting the tension (increase) on the spring, you change the pressure at which the valve opens and you also increase the system pressure. A screw pressing on the spring adjusts the tension on the valve and the system pressure.

### OIL PRESSURE RELIEF VALVE

Some large turbofan oil systems do not have a regulating valve. The system pressure varies with engine rpm and pump speed. There is a wide range of pressure in this system. A relief valve is used to relieve pressure only if it exceeds the maximum limit for the system. (*Figure 10-8*) This true relief valve system is preset to relieve pressure and bypass the oil back to the inlet side of the oil pump whenever the pressure exceeds the maximum preset system limit. This relief valve is especially important when oil coolers are incorporated in the system since the coolers are easily ruptured because of their thin-wall construction. Under normal operation, it should never open.

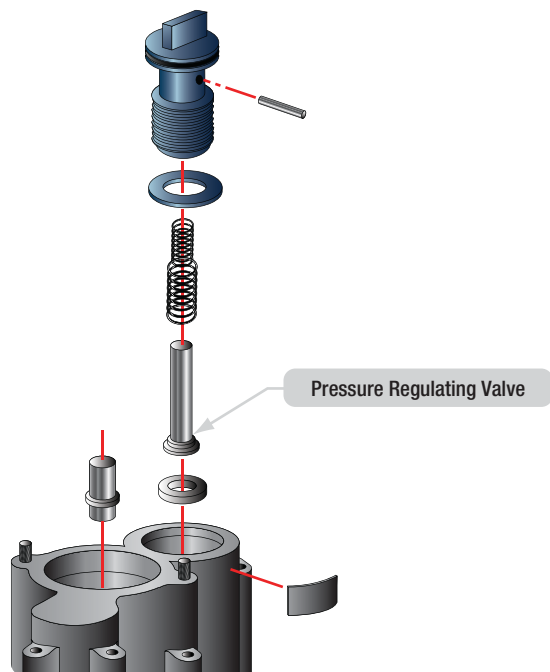

Figure 10-7. Pressure regulating valve.

### OIL JETS

Oil jets (or nozzles) are located in the pressure lines adjacent to, or within, the bearing compartments and rotor shaft couplings. (*Figure 10-9*) The oil from these nozzles is delivered in the form of an atomized spray. Some engines use an air-oil mist spray that is produced by tapping high-pressure bleed air from the compressor to the oil nozzle outlet. This method is considered adequate for ball and roller bearings; however, the solid oil spray method is considered the better of the two methods.

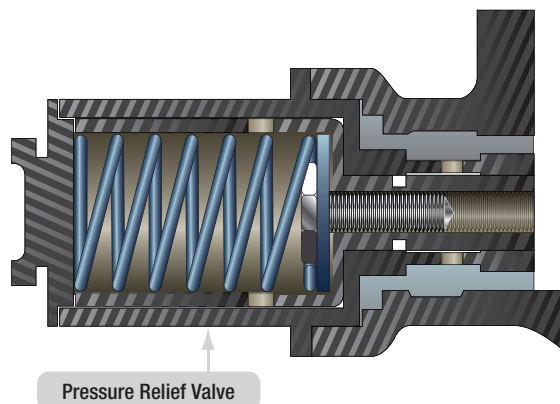

Figure 10-8. Pressure relief valve.

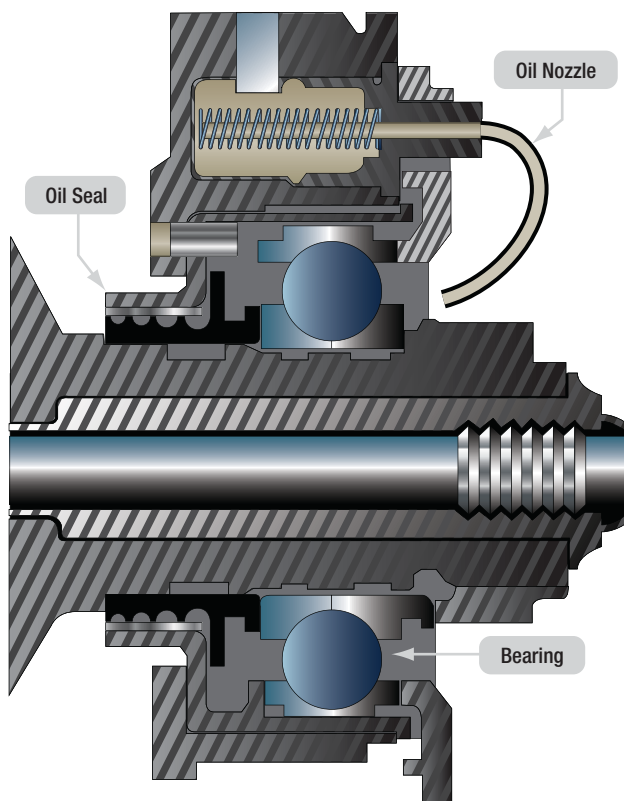

Figure 10-9. Oil nozzles spray lubricate on bearings.

The oil jets are easily clogged because of the small orifice in their tips; consequently, the oil must be free of any foreign particles. If the last-chance filters in the oil jets should become clogged, bearing failure usually results since nozzles are not accessible for cleaning except during engine maintenance. To prevent damage from clogged oil jets, main oil filters are checked frequently for contamination.

## LUBRICATION SYSTEM INSTRUMENTATION

Gauge connection provisions are incorporated in the oil system for oil pressure, oil quantity, low oil pressure, oil filter differential pressure switch, and oil temperature. The oil pressure gauge measures the pressure of the lubricant as it leaves the pump and enters the pressure system. The oil pressure transmitter connection is located in the pressure line between the pump and the various points of lubrication. An electronic sensor is placed to send a signal to the Full Authority Digital Engine Control (FADEC) control unit and through the Engine Indicating and Crew Alerting System (EICAS)

computers, and on to the displays in the flight deck. The tank quantity transmitter information is sent to the EICAS computers. The low oil pressure switch alerts the crew if the oil pressure falls below a certain pressure during engine operation. The differential oil pressure switch alerts the flight crew of an impending oil filter bypass because of a clogged filter. A message is sent to the display in the upper EICAS display in the flight deck as can be seen in *Figure 10-10*. Oil temperature can be sensed at one or more points in the engine's oil flow path. The signal is sent to the FADEC/EICAS computer and is displayed on the lower EICAS display.

## LUBRICATION SYSTEM BREATHER SYSTEMS (VENTS)

Breather subsystems are used to remove excess air from the bearing cavities and return the air to the oil tank where it is separated from any oil mixed in the vapor of air and oil by the deaerator. Then, the air is vented overboard and back to the atmosphere.

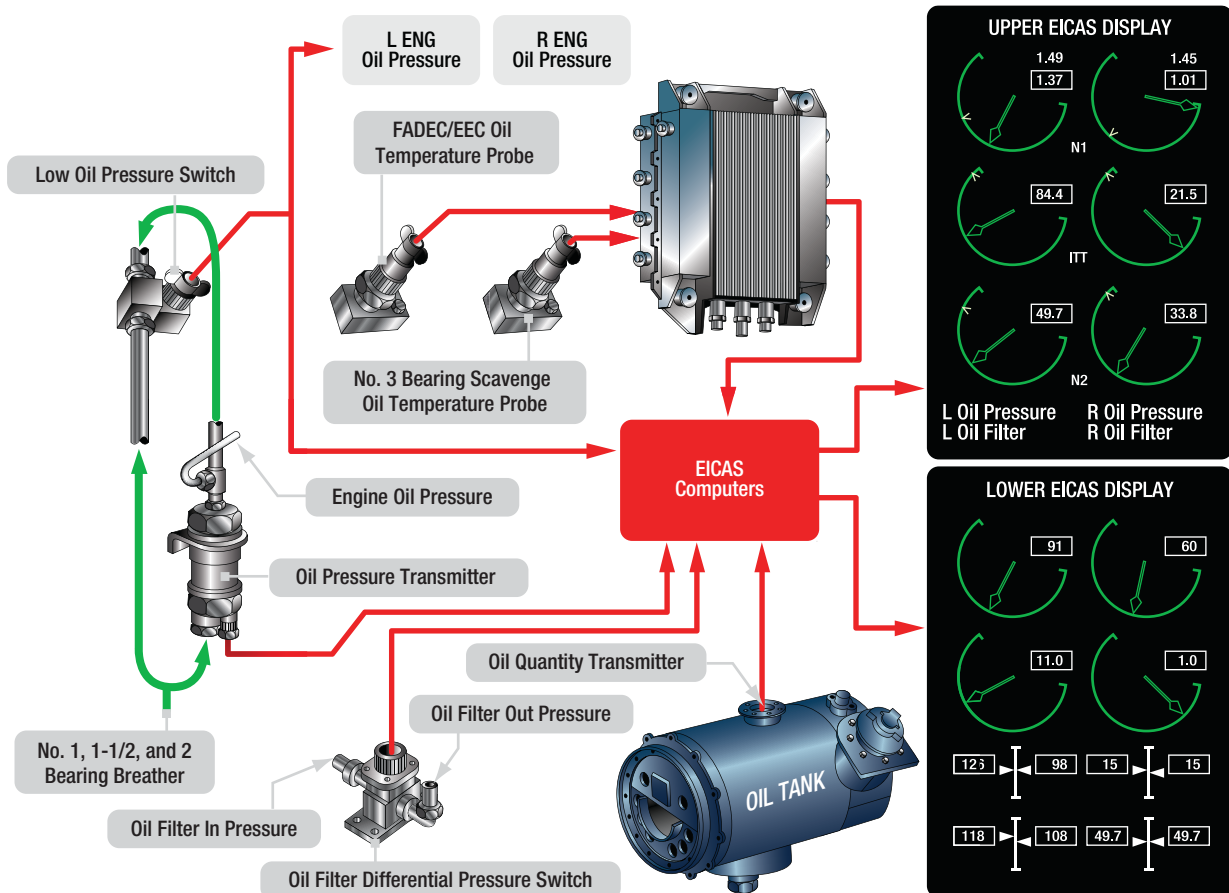

Figure 10-10. Oil indicating system.

All engine bearing compartments, oil tanks, and accessory cases are vented together so the pressure in the system remains the same.

The vent in an oil tank keeps the pressure within the tank from rising above or falling below that of the outside atmosphere. However, the vent may be routed through a check relief valve that is preset to maintain a slight (approximately 4 psi) pressure on the oil to assure a positive flow to the oil pump inlet.

In the accessory case, the vent (or breather) is a screen protected opening that allows accumulated air pressure within the accessory case to escape to the atmosphere. The scavenged oil carries air into the accessory case and this air must be vented. Otherwise, the pressure buildup within the accessory case would stop the flow of oil draining from the bearing, forcing this oil past the bearing oil seals and into the compressor housing. If in enough quantity, oil leakage could cause burning and seal and bearing malfunction. The screened breathers are usually located in the front center of the accessory case to prevent oil leakage through the breather when the aircraft is in unusual flight attitudes. Some breathers may have a baffle to prevent oil leakage during flight maneuvers. A vent that leads directly to the bearing compartment may be used in some engines. This vent equalizes pressure around the bearing surface so that the lower pressure at the first compressor stage does not cause oil to be forced past the bearing rear oil seal into the compressor.

### LUBRICATION SYSTEM CHECK VALVE

Check valves are sometimes installed in the oil supply lines of dry-sump oil systems to prevent reservoir oil from seeping (by gravity) through the oil pump elements and high-pressure lines into the engine after shutdown. Check valves, by stopping flow in an opposite direction, prevent accumulations of undue amounts of oil in the accessory gearbox, compressor rear housing, and combustion chamber. Such accumulations could cause excessive loading of the accessory drive gears during starts, contamination of the cabin pressurization air, or internal oil fires. The check valves are usually the spring-loaded ball-and-socket type constructed for free flow of pressure oil. The pressure required to open these valves varies, but the valves generally require from 2 to 5 psi to permit oil to flow to the bearings.

### LUBRICATION SYSTEM THERMOSTATIC BYPASS VALVES

Thermostatic bypass valves are included in oil systems using an oil cooler. Although these valves may be called different names, their purpose is always to maintain proper oil temperature by varying the proportion of the total oil flow passing through the oil cooler. A cutaway view of a typical thermostatic bypass valve is shown in *Figure 10-11*. This valve consists of a valve body, having two inlet ports and one outlet port, and a spring-loaded thermostatic element valve. The valve is spring loaded because the pressure drop through the oil cooler could become too great due to denting or clogging of the cooler tubing. In such a case, the valve opens, bypassing the oil around the cooler.

### AIR OIL COOLERS

Two basic types of oil coolers in general use are the air-cooled and the fuel-cooled. Air oil coolers are used in the lubricating systems of some turbine engines to reduce the temperature of the oil to a degree suitable for recirculation through the system. The air-cooled oil cooler is normally installed at the forward end of the engine. It is similar in construction and operation to the air-cooled cooler used on reciprocating engines. An air oil cooler is usually included in a dry-sump oil system. (*Figure 10-12*)

This cooler may be air-cooled or fuel-cooled and many engines use both. Dry-sump lubrication systems require coolers for several reasons. First, air cooling of bearings by using compressor bleed-air is not sufficient to cool the turbine bearing cavities because of the heat present in area of the turbine bearings. Second, the large turbofan engines normally require a greater number of bearings,

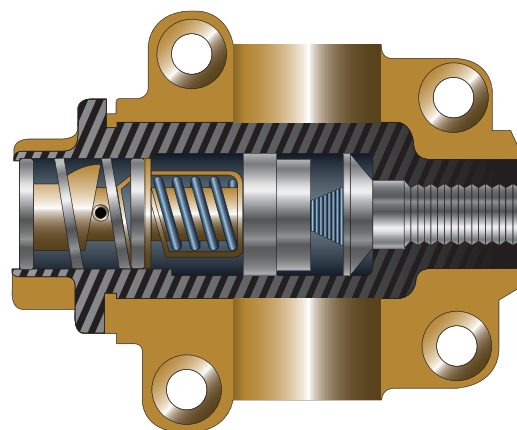

Figure 10-11. Typical thermostatic bypass valve.



Figure 10-12. Air oil cooler.

which means that more heat is transferred to the oil. Consequently, the oil coolers are the only means of dissipating the oil heat.

### FUEL OIL COOLERS

The fuel-cooled oil cooler acts as a fuel oil heat exchanger in that the fuel cools the hot oil and the oil heats the fuel for combustion. (Figure 10-13) Fuel flowing to the engine must pass through the heat exchanger; however, there is a thermostatic valve that controls the oil flow, and the oil may bypass the cooler if no cooling is needed. The fuel/oil heat exchanger consists of a series of joined tubes with an inlet and outlet port. The oil enters the inlet port, moves around the fuel tubes, and goes out the oil outlet port.

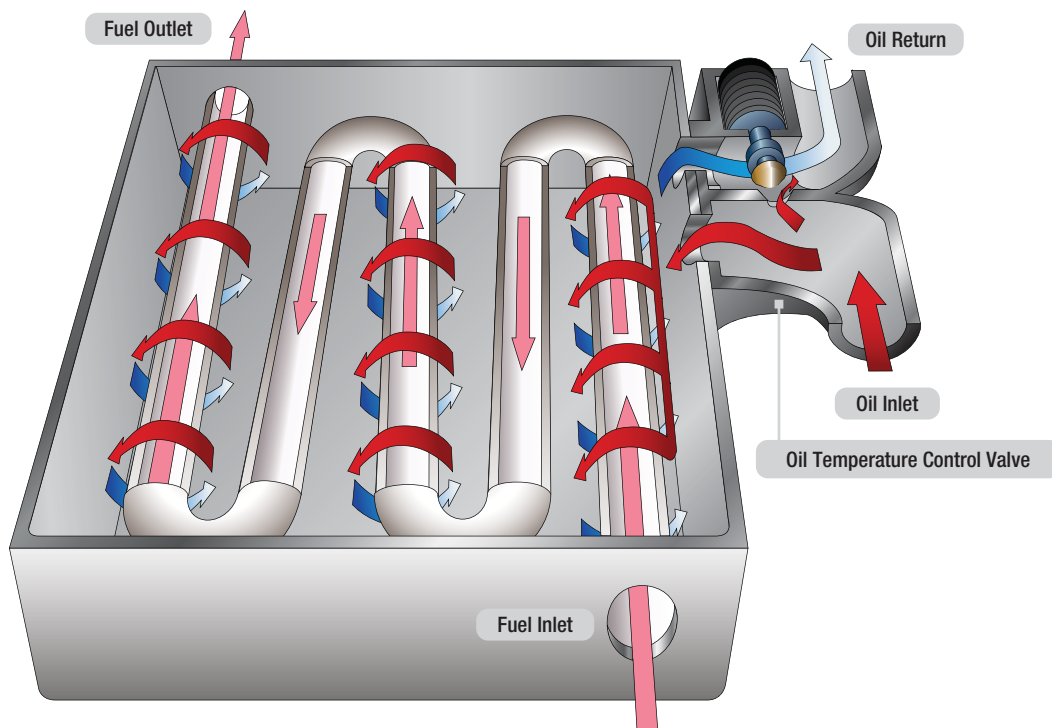

Figure 10-13. Fuel oil heat exchanger cooler.

### DEOILER

The deoiler removes the oil from the breather air. The breather air goes into an impeller that turns in the deoiler housing. Centrifugal force drives the oil towards the outer wall of the impeller. Then, the oil drains from the deoiler into a sump or oil tank. Because the air is much lighter than the oil, it goes through the center of the impeller and is vented overboard.

### MAGNETIC CHIP DETECTORS

Magnetic chip detectors are used in the oil system to detect and catch ferrous (magnetic) particles present in the oil. (Figure 10-14) Scavenge oil generally flows past chip detectors so any magnetic particles are attracted and stick to the chip detector. Chip detectors are placed in several locations but generally are in the scavenge lines for each scavenge pump, oil tank, and in the oil sumps. Some engines have several detectors to one detector. During maintenance, the chip detectors are removed from the engine and inspected for metal; if none is found, the detector is cleaned, replaced, and safety wired. If metal is found on a chip detector, an investigation should be made to find the source of the metal on the chip.

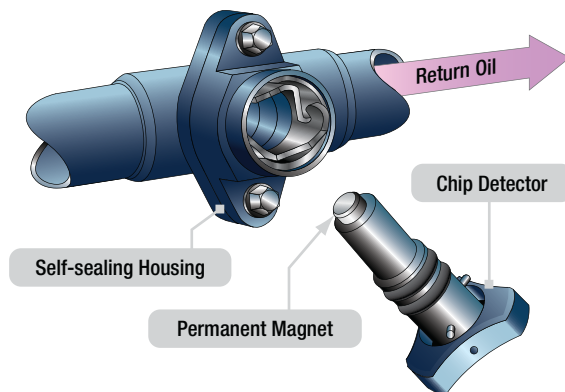

Figure 10-14. Chip detector.

## TYPICAL DRY-SUMP PRESSURE REGULATED TURBINE LUBRICATION SYSTEM

The turbine lubrication system is representative of turbine engines using a dry-sump system. (Figure 10-15) The lubrication system is a pressure regulated, high-pressure design. It consists of the pressure, scavenge, and breather subsystems. The pressure system supplies oil to the main engine bearings and to the accessory drives. The scavenger system returns the oil to the engine oil tank that is usually mounted on the compressor case. It is connected to the inlet side of the pressure oil pump and completes the oil flow cycle.

A breather system connecting the individual bearing compartments and the oil tank with the breather pressurizing valve completes the engine lubrication system. In a turbine pressure relief dry-sump lubrication system, the oil supply is carried in a tank mounted on the engine. With this type of system, a larger oil supply can be carried and the temperature of the oil can be readily controlled.

### PRESSURE SYSTEM

The oil pressure branch of the engine lubrication system is pressurized by a gear-type pressure pump located in the oil pump and accessory drive housing. (Figure 10-15) The pressure pump receives engine oil at its lower (inlet) side and discharges pressurized oil to an oil filter located on the housing. From the oil filter, which is equipped with a bypass valve for operation in case the filter clogs, the pressurized oil is transmitted to a cored passage running through to the pressure regulating (relief) valve that maintains system pressure. The pressure regulating (relief) valve is located downstream of the pump. It is adjusted to maintain a proper pressure to the oil metering jets in the engine. The pressure regulating (relief) valve is usually easily accessible for adjustment. Then, the oil flows through the fuel oil cooler and on to the bearing cavities through last-chance filters and out spray nozzles to the bearings. Pressurized oil distributed to the engine main bearings is sprayed on the bearings through fixed orifice nozzles providing a relatively constant oil flow at all engine operating speeds.

### SCAVENGE SYSTEM

The scavenge system scavenges the main bearing compartments and circulates the scavenged oil back to the tank. The scavenge oil system includes five gear-type pumps. (Figure 10-15) The No.1 bearing oil scavenge pump scavenges accumulated oil from the front bearing case. It directs the oil through an external line to a central collecting point in the main accessory gearbox. The oil return from No. 2 and 3 bearings is through internal passages to a central collecting point in the main accessory case. The accessory gearbox oil suction

pump, located in the main accessory gearbox, scavenges oil from the gearbox housing to the oil tank. Oil from the No. 4, No. 4½ and No. 5 bearing accumulates in the bearing cavity and is scavenged to the accessory gearbox.

The turbine rear bearing oil suction pump scavenges oil from the No. 6 bearing compartment and directs the scavenged oil through a passage in the turbine case strut. From there, it is directed to the bearing cavity for the 4, 4½, and 5 bearing cavity where it joins this oil

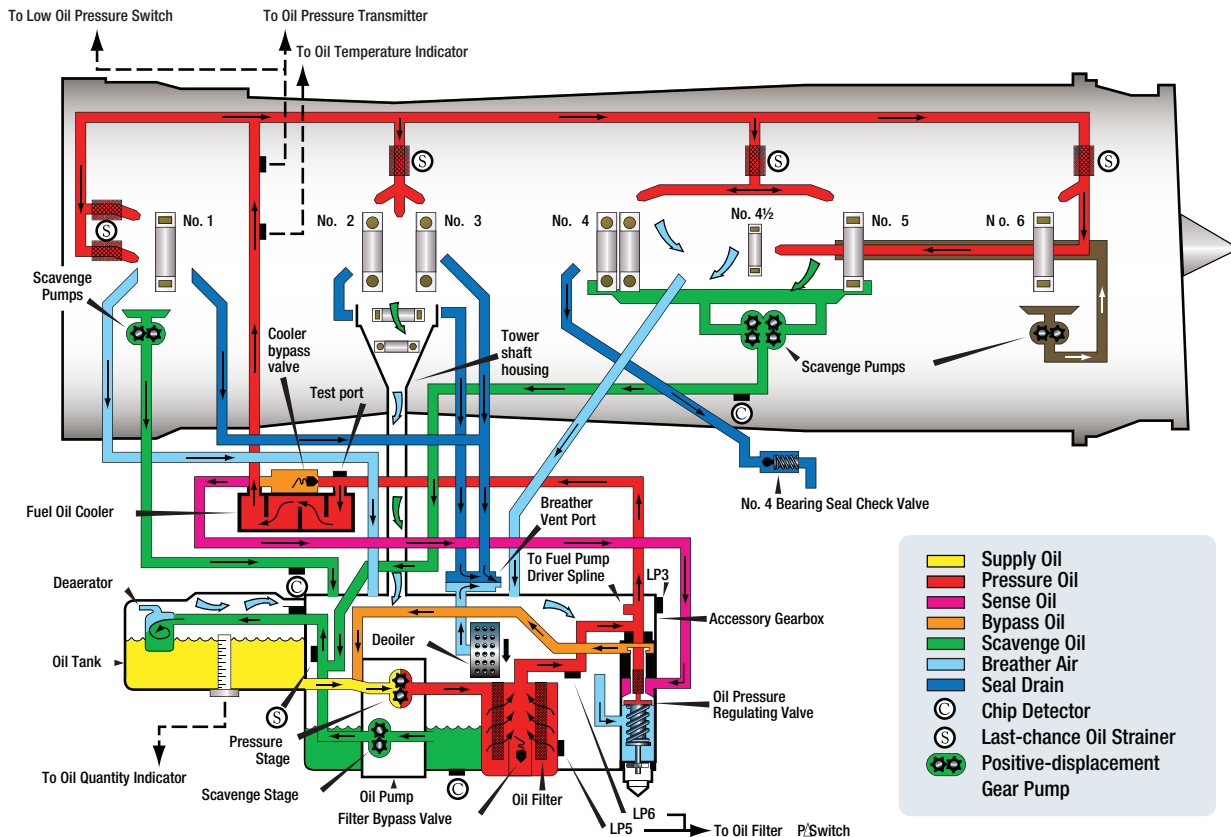

Figure 10-15. Typical turbine dry-sump pressure regulated lubrication system.

and is returned to the oil tank. The scavenge oil passes through the deaerator as it enters the oil tank, which separates the air mixed in the return oil. The oil stays in the tank while the air flows into the accessory gearbox and enters the deoiler.

### BREATHER PRESSURIZING SYSTEM

The breather pressurizing system ensures a proper oil spray pattern from the main bearing oil jets and

furnishes a pressure head to the scavenge system. Breather tubes in the compressor inlet case, the oil tank, the diffuser case, and the turbine exhaust case are connected to external tubing at the top of the engine. By means of this tubing, the vapor-laden atmospheres of the various bearing compartments and the oil tank are brought together in the deoiler in the accessory gearbox. The deoiler separates out the oil from the air/oil mist and vents the air back to the atmosphere.

## TYPICAL DRY-SUMP VARIABLE PRESSURE LUBRICATION SYSTEM

The dry-sump variable-pressure lubrication system uses the same basic subsystems that the regulated systems used (pressure scavenge breather). (Figure 10-16)

The main difference is that the pressure in this system is not regulated by a regulating bypass valve. Most large turbofan engine pressure systems are variable-pressure systems in which the pump outlet pressure (oil pressure) depends on the engine rpm. In other words, the pump output pressure is proportional to the engine speed. Since the resistance to flow in the system does not vary much during operation and the pump has only the variable

of turning faster or slower, the pressure is a function of engine speed. As an example, oil pressure can vary widely in this type of system, from 100 psi to over 260 psi, with the relief valve opening at about 540 psi.

### PRESSURE SUBSYSTEM

The oil flows from the oil tank down to the pressure stage of the oil pump. A slight pressure in the tank assures that the flow of oil into the pressure pump is continuous. After being pressurized, it moves on to the oil filter where it is filtered.

If the filter is clogged, the bypass valve sends the oil around the filter. There is no regulating valve but there is a relief valve to prevent the system pressure from exceeding the maximum limits. This valve is usually set to open well above the systems operating pressure. The oil flows from the filter housing to the engine air/oil cooler. The oil either bypasses the cooler (cold) or passes through the cooler (hot) and then on to the fuel oil cooler. Through the use of the coolers, the fuel temperature is adjusted to meet the requirements needed for the engine. Some of the oil passes through the classified oil pressure trim orifice that helps adjust oil pressure at low speeds. The oil now flows through the last-chance oil filters (strainers) that remove particles from the oil if the oil filter has been bypassed. The engine oil passes through the nozzles to lubricate the bearings, gearboxes, seals, and accessory drive splines. After performing its functions of lubricating, cleaning, and cooling the bearings, the oil needs to be returned to the oil tank by the scavenge system.

## SCAVENGER SUBSYSTEM

The scavenger oil pump has several stages that pull oil from the bearing compartments and gear boxes and sends the oil to the tank. At the tank, the oil enters the deaerator, which separates the air from the scavenge oil. The oil returns to the tank and the air is vented through a check valve overboard. Each stage of the scavenge pump has a magnetic chip detector that can be removed for inspection.

## BREATHER SUBSYSTEMS

The purpose of the breather system is to remove air from the bearing compartments, separate breather air from oil, and vent the air overboard. The breather air from the bearing compartments is drawn to the gearbox by the deoiler. The deoiler is turned at high speed and causes the oil to separate from the air. The air is then vented with air from the deaerator overboard. By referring to *Figure 10-16*, notice that the deaerator is in the oil tank and the deoiler is in the main gear box.

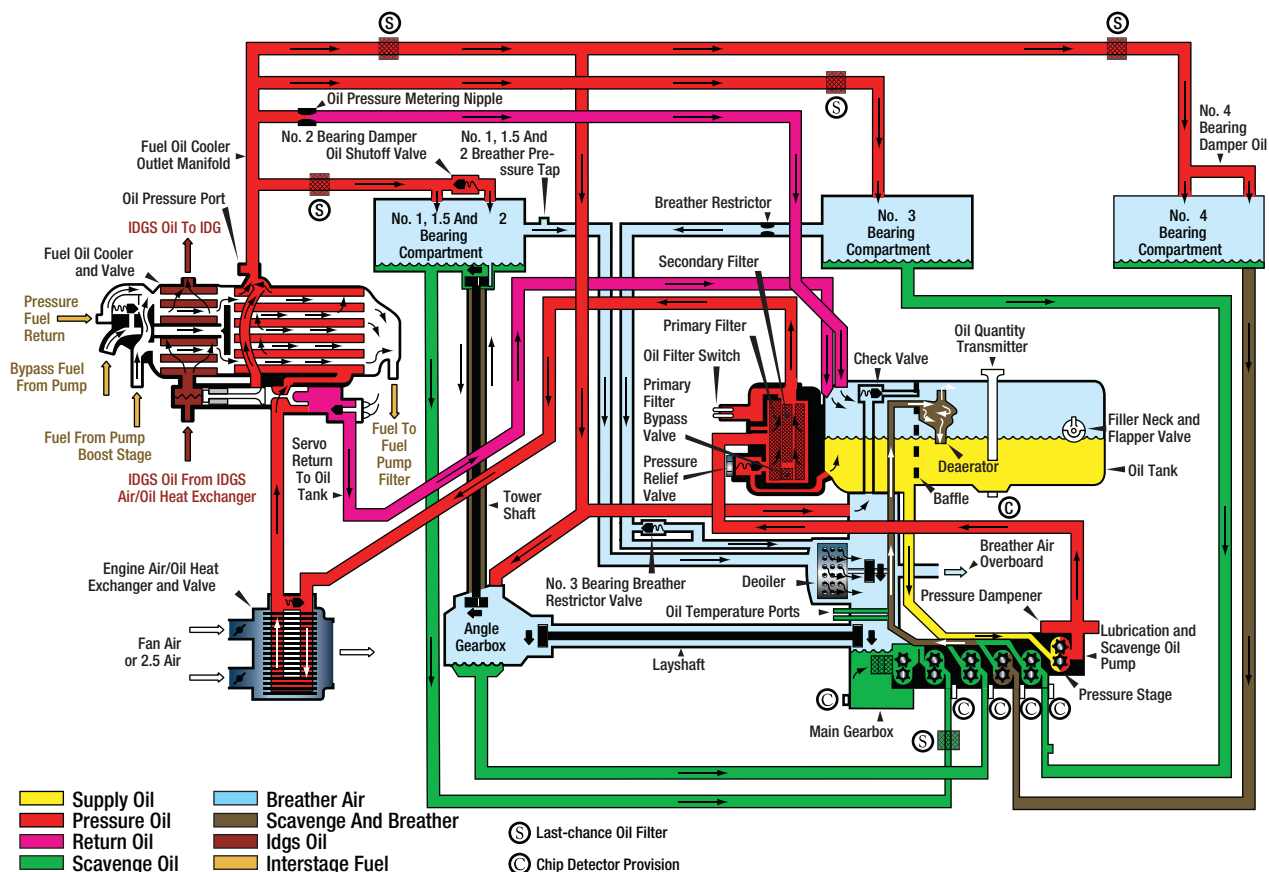

Figure 10-16. Typical turbine dry-sump variable pressure lubrication system.

## TURBINE ENGINE WET-SUMP LUBRICATION SYSTEM

In some engines, the lubrication system is the wet-sump type. There are relatively few engines using a wet-sump type of oil system. A wet-sump oil system is shown in *Figure 10-17*. The components of a wet-sump system are similar to those of a dry-sump system. The major difference between the two systems is the location of the oil reservoir. The reservoir for the wet-sump oil system may be the accessory gear case or it may be a sump mounted on the bottom of the accessory case. Regardless of configuration, reservoirs for wet-sump systems are an integral part of the engine and contain the bulk of the engine oil supply. (*Figure 10-17*) Included in the wet-sump reservoir are the following components:

1. A sight gauge indicates the oil level in the sump.
2. A vent or breather equalizes pressure within the accessory casing.
3. A magnetic drain plug may be provided to drain the oil and also to trap any ferrous metal particles in the oil. This plug should always be examined closely during inspections. The presence of metal particles may indicate gear or bearing failure.
4. Provision may also be made for a temperature bulb and an oil pressure fitting.

This system is typical of all engines using a wet-sump lubrication system. The bearing and drive gears in the accessory drive casing are lubricated by a splash system. The oil for the remaining points of lubrication leaves the pump under pressure and passes through a filter to jet nozzles that direct the oil into the rotor bearings and couplings. The oil is returned to the reservoir (sump) by gravity. Oil from the compressor bearing and the accessories drive coupling shaft drains directly into the reservoir. Turbine oil drains into a sump where the oil was originally pumped.

### ACCESSORY SECTION

The accessory section of the gas turbine engine has various functions. The primary function is to provide space for the mounting of accessories necessary for operation and control of the engine. Generally, it also includes accessories concerned with the aircraft, such as electric generators and hydraulic pumps. Secondary functions include acting as an oil reservoir and/or oil sump and housing the accessory drive gears and reduction gears.



Figure 10-17. Typical turbine wet sump system.

The arrangement and driving of accessories has always been a major problem on gas turbine engines. Driven accessories on turboprops are usually mounted on the accessory gear box, which is on the bottom of the engine. The location of the accessory gear box varies somewhat, but most turboprops and turboshafts have the accessory cases mounted to the back section of the engine.

The components of the accessory section of all gas turbine engines have essentially the same purpose, even though they often differ quite extensively in construction details and nomenclature.

The basic elements of the accessory section are:

1. The accessory case, which has machined mounting pads for the engine-driven accessories, and
2. The gear train, which is housed within the accessory case.

The accessory case may be designed to act as an oil reservoir. If an oil tank is utilized, a sump is usually provided below the front bearing support for the drainage and scavenging of oil used to lubricate bearings and drive gears. The accessory case is also provided with adequate tubing or cored passages for spraying, lubricating oil on the gear train and supporting bearings.



The gear train is driven by the engine high-pressure compressor through an accessory drive shaft (tower shaft) gear coupling, which splines with a gear box gear and the high-pressure compressor. The reduction gearing within the case provides suitable drive speeds for each engine accessory or component. Because the rotor operating rpm is so high, the accessory reduction gear ratios are relatively high. The accessory drives are supported by ball bearings assembled in the mounting pad bores of the accessory case. (*Figure 10-18*)

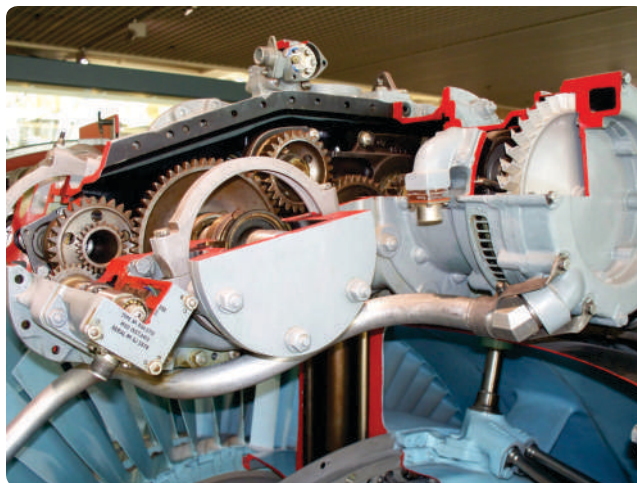

Figure 10-18. Cutaway view of an accessory case of a Rolls Royce Pegasus engine.

**Question:** 10-1

Which type of lubrication system is used on turbine engines?

- A. Wet Sump.
- B. Dry sump.
- C. Wet or dry sump.

**Question:** 10-5

Where in the system is a "last chance" oil filter placed?

**Question:** 10-2

The two most common turbine engine oil pumps are the gear and gerotor, with the \_\_\_\_\_-type being the most commonly used.

**Question:** 10-6

What occurs to protect the engine if an oil filter becomes clogged?

**Question:** 10-3

Where does a true relief valve oil system on a turbine engine relieve pressure to?

**Question:** 10-7

Four cockpit indicators monitor the condition of the lubricating system. They are?

**Question:** 10-4

Two basic types of oil coolers in general use on turbine engines are the air-cooled and the \_\_\_\_\_-cooled.

**Question:** 10-8

A deoiler removes \_\_\_\_\_ air from the oil by means of \_\_\_\_\_ force.

## ANSWERS

*Answer:* 10-1

C. Wet or dry sump.

*Answer:* 10-5

Just before each the spray nozzle.

*Answer:* 10-2

gear.

*Answer:* 10-6

A filter bypass valve opens allowing unfiltered oil through the system.

*Answer:* 10-3

The inlet side of the pump.

*Answer:* 10-7

oil pressure, oil quantity, oil temperature, oil filter pressure differential

*Answer:* 10-4

fuel.

*Answer:* 10-8

air; centrifugal



PART-66 SYLLABUS **LEVELS**  
 CERTIFICATION CATEGORY → **A1** **B1**

**Sub-Module 11**  
**FUEL SYSTEMS**

Knowledge Requirements

*15.11 - Fuel Systems*

Operation of engine control and fuel metering systems including electronic engine control (FADEC);  
 Systems lay-out and components.

CERTIFICATION CATEGORY →	A1	B1
	1	2

**Level 1**

A familiarization with the principal elements of the subject.

*Objectives:*

- (a) The applicant should be familiar with the basic elements of the subject.
- (b) The applicant should be able to give a simple description of the whole subject, using common words and examples.
- (c) The applicant should be able to use typical terms.

**Level 2**

A general knowledge of the theoretical and practical aspects of the subject and an ability to apply that knowledge.

*Objectives:*

- (a) The applicant should be able to understand the theoretical fundamentals of the subject.
- (b) The applicant should be able to give a general description of the subject using, as appropriate, typical examples.
- (c) The applicant should be able to use mathematical formula in conjunction with physical laws describing the subject.
- (d) The applicant should be able to read and understand sketches, drawings and schematics describing the subject.
- (e) The applicant should be able to apply his knowledge in a practical manner using detailed procedures.

---

# TURBINE ENGINE FUEL SYSTEMS

## GENERAL REQUIREMENTS

The fuel system is one of the more complex aspects of the gas turbine engine. It must be possible to increase or decrease the power at will to obtain the thrust required for any operating condition. In turbine-powered aircraft, this control is provided by varying the flow of fuel to the combustion chambers. However, some turboprop aircraft also use variable-pitch propellers; thus, the selection of thrust is shared by two controllable variables, fuel flow and propeller blade angle.

The quantity of fuel supplied must be adjusted automatically to correct for changes in ambient temperature or pressure. If the quantity of fuel becomes excessive in relation to mass airflow through the engine, the limiting temperature of the turbine blades can be exceeded, or it will produce compressor stall and a condition referred to as rich blowout. This occurs when the amount of oxygen in the air supply is insufficient to support combustion and when the mixture is cooled below the combustion temperature by the excess fuel. The other extreme, lean flame-out, occurs if the fuel quantity is reduced proportionally below the air quantity. The engine must operate through acceleration and deceleration without any fuel-control-related problems.

The fuel system must deliver fuel to the combustion chambers not only in the right quantity, but also in the right condition for satisfactory combustion. The fuel nozzles form part of the fuel system and atomize or vaporize the fuel so that it ignites and burns efficiently. The fuel system must also supply fuel so that the engine can be easily started on the ground and in the air. This means that the fuel must be injected into the combustion chambers in a combustible condition during engine starting, and that combustion must be sustained while the engine is accelerating to its normal idling speed.

Another critical condition to which the fuel system must respond occurs during a rapid acceleration. When the engine is accelerated, energy must be furnished to the turbine in excess of that necessary to maintain a constant rpm. However, if the fuel flow increases too rapidly, an over rich mixture can be produced, with the possibility of a rich blowout or compressor stall.

Turbofan, turbojet, turboshaft, and turboprop engines are equipped with a fuel control unit which automatically satisfies the requirements of the engine. Although the basic requirements apply generally to all gas turbine engines, the way in which individual fuel controls meet these needs cannot be conveniently generalized.

## TURBINE FUEL CONTROLS

Gas turbine engine fuel controls can be divided into three basic groups:

1. Hydromechanical
2. Hydromechanical/Electronic
3. Full Authority Digital Engine (or Electronics) Control (FADEC)

The hydromechanical/electronic fuel control is a hybrid of the two types of fuel control, but can function solely as a hydromechanical control. In the dual mode, inputs and outputs are electronic, and fuel flow is set by servo motors. The third type, FADEC, uses electronic sensors for its inputs and controls fuel flow with electronic outputs. The FADEC-type control gives the electronic controller (computer) complete control. The computing section of the FADEC system depends completely on sensor inputs to the electronic engine control (EEC) to meter the fuel flow. The fuel metering device meters the fuel using only outputs from the EEC. Most turbine fuel controls are quickly going to the FADEC type of control. This electronically controlled fuel control is very accurate in scheduling fuel by sensing many of the engine parameters.

Regardless of the type, all fuel controls accomplish the same function. That function is to schedule the fuel flow to match the power required by the pilot. Some sense more engine variables than others. The fuel control can sense many different inputs, such as power lever position, engine rpm for each spool, compressor inlet pressure and temperature, burner pressure, compressor discharge pressure, and many more parameters as needed by the specific engine. These variables affect the amount of thrust that an engine produces for a given fuel flow. By sensing these parameters, the fuel control has a clear picture of what is happening in the engine and can adjust fuel flow as needed. Each type of turbine engine has its own specific needs for fuel delivery and control.

### HYDROMECHANICAL FUEL CONTROLS

Hydromechanical fuel controls were used and are still used on many engines, but their use is becoming limited, giving way to electronic based controls. Fuel controls have two sections, computing and metering, to provide the correct fuel flow for the engine. A pure hydromechanical fuel control has no electronic interface assisting in computing or metering the fuel flow. It also is generally driven by the gas generator gear train of the engine to sense engine speed. Other mechanical engine parameters that are sensed are compressor discharge pressure, burner pressure, exhaust temperature, and inlet air temperature and pressure. Once the computing section determines the correct amount of fuel flow, the metering section through cams and servo valves delivers the fuel to the engine fuel system.

Actual operating procedures for a hydromechanical fuel control is very complicated and still the fuel metering is not as accurate as with an electronic type of interface or control. Electronic controls can receive more inputs with greater accuracy than hydromechanical controls. Early electronic controls used a hydromechanical control with an electronic system added on the system to fine tune the metering of the fuel. This arrangement

also used the hydromechanical system as a backup if the electronic system failed. (Figure 11-1)

### HYDROMECHANICAL/ELECTRONIC FUEL CONTROL

The addition of the electronic control to the basic hydromechanical fuel control was the next step in the development of turbine engine fuel controls. Generally, this type of system used a remotely located EEC to adjust the fuel flow. A description of a typical system is explained in the following information.

The basic function of the engine fuel system is to pressurize the fuel, meter fuel flow, and deliver atomized fuel to the combustion section of the engine. Fuel flow is controlled by a hydromechanical fuel control assembly, which contains a fuel shutoff section and a fuel metering section.

This fuel control unit is sometimes mounted on the vane fuel pump assembly. It provides the power lever connection and the fuel shutoff function. The unit provides mechanical overspeed protection for the gas generator spool during normal (automatic mode) engine operation. In automatic mode, the EEC is in

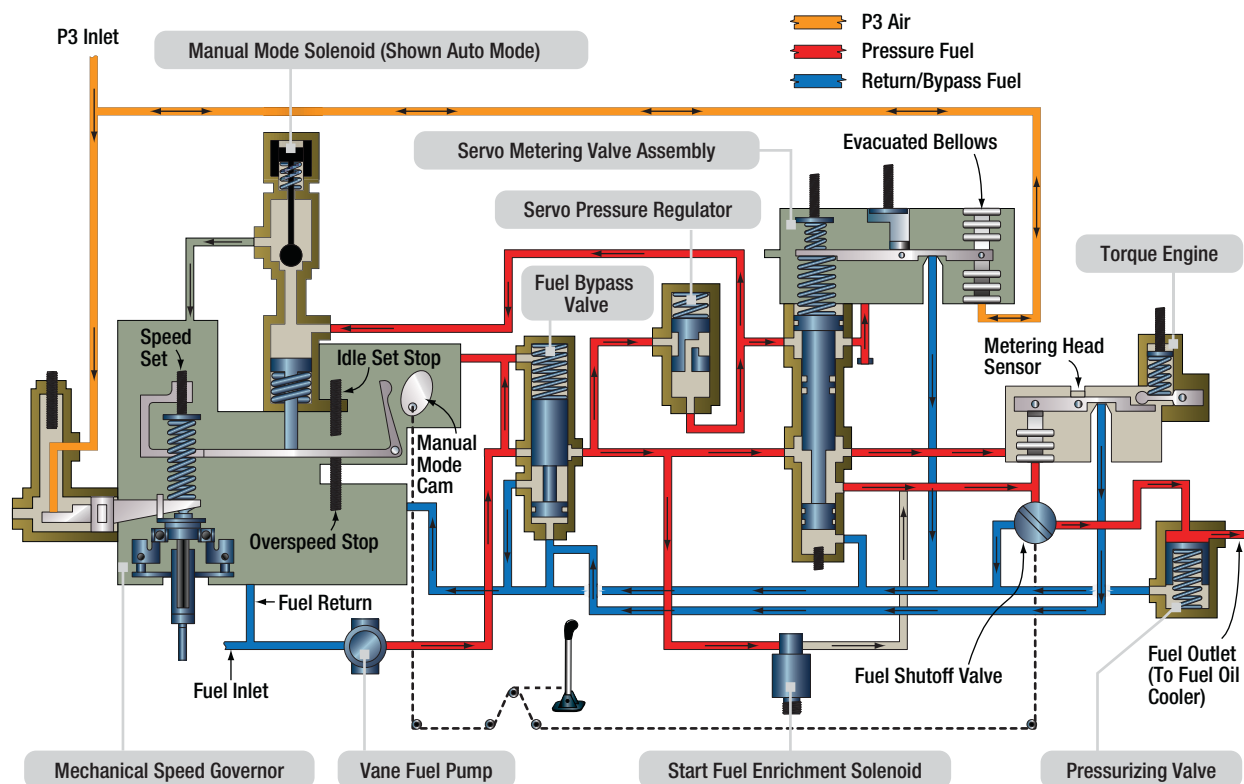

Figure 11-1. Fuel control assembly schematic hydromechanical/electronic.

control of metering the fuel. In manual mode, the hydromechanical control takes over.

During normal engine operation, a remotely mounted electronic fuel control unit (EFCU) (same as an EEC) performs the functions of thrust setting, speed governing, acceleration, and deceleration; limited through EFCU outputs to the fuel control assembly in response to power lever inputs. In the event of electrical or EFCU failure, or at the option of the pilot, the fuel control assembly functions in manual mode to allow engine operation at reduced power under control of the hydromechanical portion of the controller only.

The total engine fuel and control system consists of the following components and provides the functions as indicated:

1. The vane fuel pump assembly is a fixed displacement fuel pump that provides high pressure fuel to the engine fuel control system. (*Figure 11-2*)
2. The filter bypass valve in the fuel pump allows fuel to bypass the fuel filter when the pressure drop across the fuel filter is excessive. An integral differential pressure indicator visually flags an excessive differential pressure condition before bypassing occurs by extending a pin from the fuel filter bowl. Fuel pump discharge flow in excess of that required by the fuel control assembly is returned from the control to the pump interstage.
3. The hydromechanical fuel control assembly provides the fuel metering function of the EFCU.

Fuel is supplied to the fuel control through a 200-micron inlet filter screen and is metered to the engine by the servo-operated metering valve. It is a fuel flow/compressor discharge pressure (Wf/P3) ratio device that positions the metering valve in response to engine compressor discharge pressure (P3). Fuel pressure differential across the servo valve is maintained by the servo-operated bypass valve in response to commands from the EFCU. (*Figure 11-1*)

The manual mode solenoid valve is energized in the automatic mode. The automatic mode restricts operation of the mechanical speed governor. It is restricted to a single overspeed governor setting above the speed range controlled electronically. De-energizing the manual mode valve enables the mechanical speed governor to function as an all speed governor in response to power



Figure 11-2. Fuel pump and filter.

lever angle (PLA). The fuel control system includes a low power sensitive torque motor which may be activated to increase or decrease fuel flow in the automatic mode (EFCU mode). The torque motor provides an interface to an electronic control unit that senses various engine and ambient parameters and activates the torque motor to meter fuel flow accordingly. This torque motor provides electromechanical conversion of an electrical signal from the EFCU. The torque motor current is zero in the manual mode, which establishes a fixed Wf/P3 ratio.

This fixed Wf/P3 ratio is such that the engine operates surge free and is capable of producing a minimum of 90 percent thrust up to 30 000 feet for this example system. All speed governing of the high-pressure spool (gas generator) is achieved by the flyweight governor. The flyweight governor modulates a pneumatic servo, consistent with the speed set point as determined by the power lever angle (PLA) setting. The pneumatic servo accomplishes Wf/P3 ratio modulation to govern the gas generator speed by bleeding down the P3 acting on the metering valve servo. The P3 limiter valve bleeds down the P3 pressure acting in the metering valve servo when engine structural limits are encountered in either control mode. The start fuel enrichment solenoid valve provides additional fuel flow in parallel with the metering valve when required for engine cold starting or altitude restarts. The valve is energized by the EFCU when enrichment is required. It is always de-energized in the manual mode to prevent high altitude sub-idle operation.

Located downstream of the metering valve are the manual shutoff and pressurizing valves. The shutoff valve is a rotary unit connected to the power lever. It allows the pilot to direct fuel to the engine manually.

The pressurizing valve acts as a discharge restrictor to the hydromechanical control. It functions to maintain minimum operating pressures throughout the control. The pressurizing valve also provides a positive leak-tight fuel shutoff to the engine fuel nozzles when the manual valve is closed.

4. The flow divider and drain valve assembly proportions fuel to the engine primary and secondary fuel nozzles. It drains the nozzles and manifolds at engine shutdown. It also incorporates an integral solenoid for modifying the fuel flow for cold-starting conditions.

During an engine start, the flow divider directs all flow through the primary nozzles. After start, as the engine fuel demand increases, the flow divider valve opens to allow the secondary nozzles to function. During all steady-state engine operation, both primary and secondary nozzles are flowing fuel. A 74-micron, self-bypassing screen is located under the fuel inlet fitting and provides last chance filtration of the fuel prior to the fuel nozzles.

5. The fuel manifold assembly is a matched set consisting of both primary and secondary manifolds and the fuel nozzle assemblies.

Twelve fuel nozzles direct primary and secondary fuel through the nozzles causing the fuel to swirl and form a finely atomized spray. The manifold assembly provides fuel routing and atomizing to ensure proper combustion.

The EEC system consists of the hydromechanical fuel control, EFCU, and aircraft mounted power lever angle potentiometer. Aircraft generated control signals include inlet pressure, airstream differential pressure, and inlet temperature plus pilot selection of either manual or auto mode for the EFCU operation. Engine generated control signals include fan spool speed, gas generator spool speed, inner turbine temperature, fan discharge temperature, and compressor discharge pressure. Aircraft and engine generated control signals are directed to the EFCU where these signals are interpreted. The PLA potentiometer is aircraft mounted in the throttle quadrant. The PLA potentiometer transmits an electrical signal to the EFCU, which represents engine thrust demand in relation to throttle position. If the EFCU determines a power change is

required, it commands the torque motor to modulate differential pressure at the head sensor. This change in differential pressure causes the metering valve to move, varying fuel flow to the engine as required. The EFCU also receives a pilot initiated signal (by power lever position) representing engine thrust demand. The EFCU is programmed to recognize predetermined engine operating limits and to compute output signals such that these operating limits are not exceeded.

The EFCU is remotely located and airframe mounted. An interface between the EFCU and aircraft/engine is provided through the branched wiring harness assembly. (*Figure 11-3*)

## FADEC FUEL CONTROL SYSTEMS

A full authority digital electronic control (FADEC) has been developed to control fuel flow on most new turbine engine models. A true FADEC system has no hydromechanical fuel control backup system. The system uses electronic sensors that feed engine parameter information into the EEC. The EEC gathers the needed information to determine the amount of fuel flow and transmits it to a fuel metering valve. The fuel metering valve simply reacts to the commands from the EEC. The EEC is the computing section of the fuel delivery system and the metering valve meters the fuel flow. FADEC systems are used on many turbine engines from APUs to the largest propulsion engines.

## FADEC FOR AN AUXILIARY POWER UNIT

The first example system is an APU engine that uses the aircraft fuel system to supply fuel to the fuel control. An electric boost pump may be used to supply fuel under pressure to the control. The fuel usually passes through an aircraft shutoff valve that is tied to the fire detecting/ extinguishing system. An aircraft furnished in-line fuel filter may also be used. Fuel entering the fuel control unit first passes through a 10-micron filter. If the filter becomes contaminated, the resulting pressure drop opens the filter bypass valve and unfiltered fuel then is supplied to the APU. Shown in *Figure 11-4* is a pump with an inlet pressure access plug so that a fuel pressure gauge might be installed for troubleshooting purposes. Fuel then enters a positive displacement, gear-type pump. Upon discharge from the pump, the fuel passes through a 70-micron screen. The screen is installed at this point to filter any wear debris that might



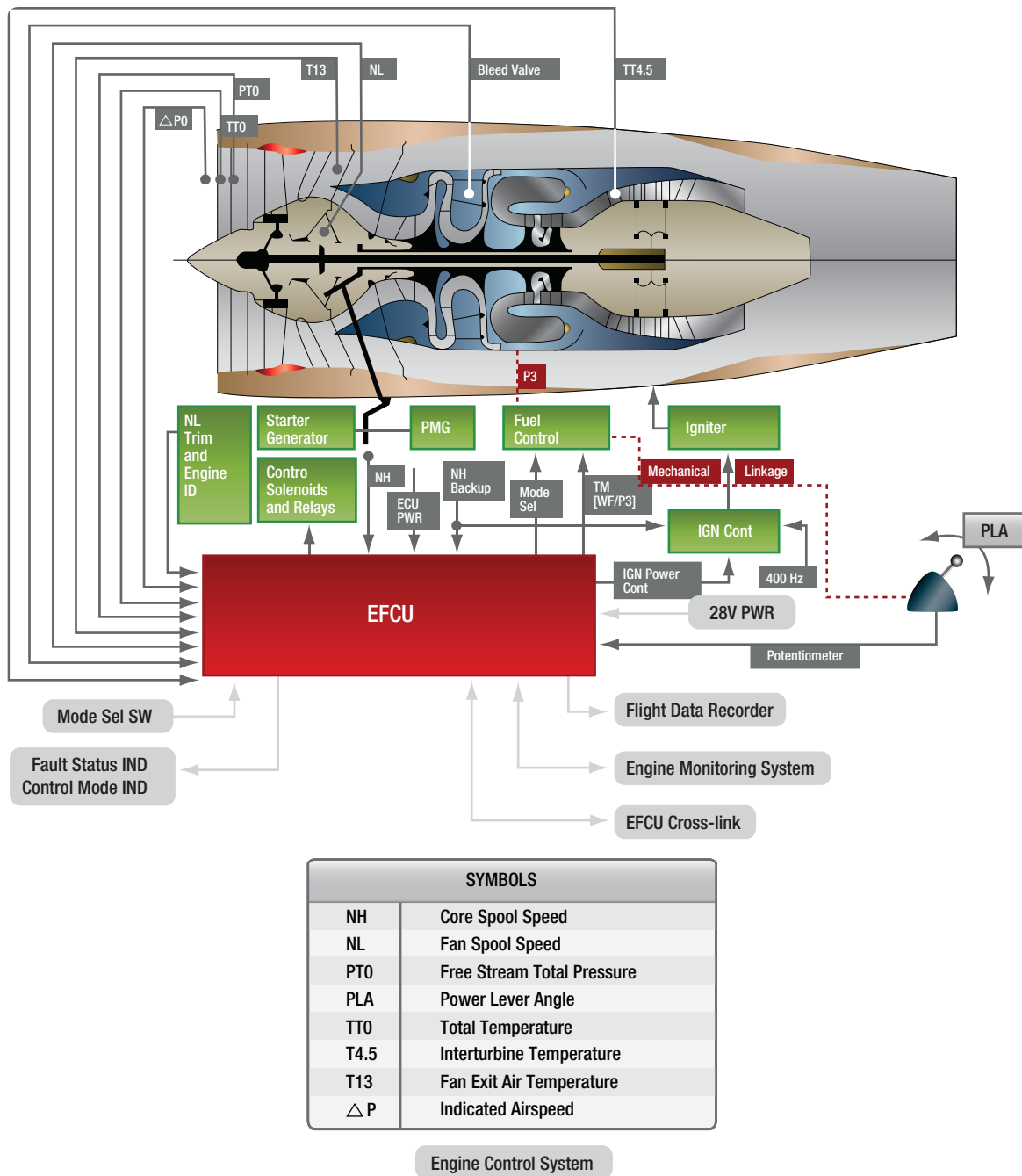

Figure 11-3. Engine control system.

be discharged from the pump element. From the screen, fuel branches to the metering valve, differential pressure valve, and the ultimate relief valve. Also shown at this point is a pump discharge pressure access plug, another point where a pressure gauge might be installed.

The differential pressure valve maintains a constant pressure drop across the metering valve by bypassing fuel to the pump inlet so that metered flow is proportional to metering valve area. The metering valve area is modulated by the torque motor, which receives variable

current from the ECU. The ultimate relief valve opens to bypass excess fuel back to the pump inlet whenever system pressure exceeds a predetermined pressure. This occurs during each shutdown since all flow is stopped by the shutoff valve and the differential pressure valve, is unable to bypass full pump capacity. Fuel flows from the metering valve out of the fuel control unit (FCU), through the solenoid shutoff valve and on to the atomizer. Initial flow is through the primary nozzle tip only. The flow divider opens at higher pressure and adds flow through the secondary path.

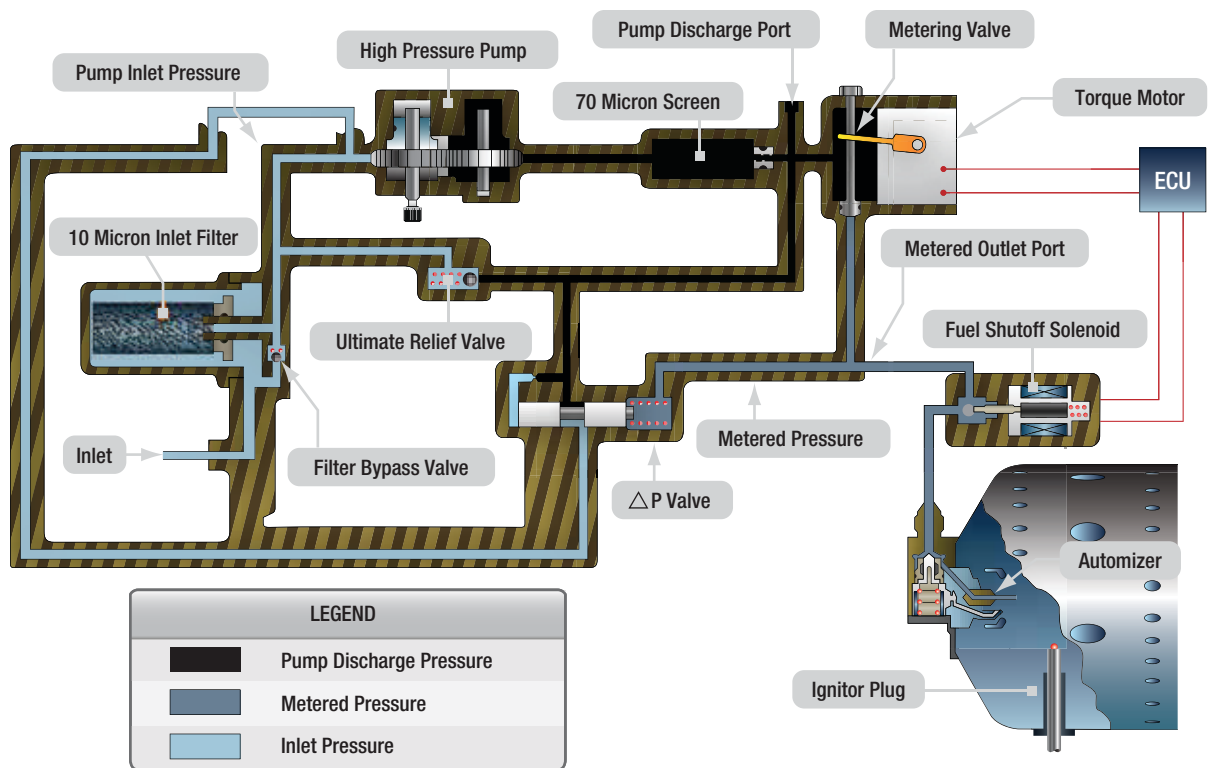

Figure 11-4. APU fuel system schematic.

## FADEC FUEL CONTROL PROPULSION ENGINE

Many large high-bypass turbofan engines use the FADEC type of fuel control system. The EEC is the primary component of the FADEC engine fuel control system. The EEC is a computer that controls the operation of the engine. The EEC housing contains two electronic channels (two separate computers) that are physically separated internally and are naturally cooled by convection. The EEC is generally placed in an area of the engine nacelle that is cool during engine operation. It attaches to the lower-left fan case with shock mounts. (*Figure 11-5*)

The EEC computer uses data it receives from many engine sensors and airplane systems to control the engine operation. It receives electronic signals from the flight deck to set engine power or thrust. The throttle lever angle resolver supplies the EEC with a signal in proportion to the thrust lever position.

Power for the EEC comes from the aircraft electrical system or the permanent magnet alternator (PMA). When the engine is running, the (PMA) supplies power to the EEC directly. The EEC is a two channel computer that controls every aspect of engine operation. Each channel, which is an independent computer, can completely control the operation of the engine.

The processor does all of the control calculations and supplies all the data for the control signals for the torque motors and solenoids. The cross-talk logic compares data from channels A and B and uses the cross-talk logic to find which EEC channel is the best to control the output driver for a torque motor or solenoid bank. The primary channel controls all of the output drivers. If the cross-talk logic finds that the other channel is better for control of a specific bank, the EEC changes control of that one bank to the other channel. The EEC has output driver banks that supply the control signals to engine components. The EEC has both volatile and nonvolatile memory to store performance and maintenance data.

The EEC can control the engine thrust in two modes which can be selected by use of a mode selection switch. In the normal mode, engine thrust is set through engine pressure ratio (EPR); in the alternate mode, thrust is set by N1. When the fuel control switch is moved from run to cutoff, the EEC resets. During this reset, all fault data is recorded in the nonvolatile memory. The EEC controls the metering valve in the fuel metering unit to supply fuel flow for combustion. (*Figure 11-6*)

The fuel metering unit (FMU), is mounted on the front face of the gearbox and is attached to the front of the fuel pump. (*Figure 11-7*)

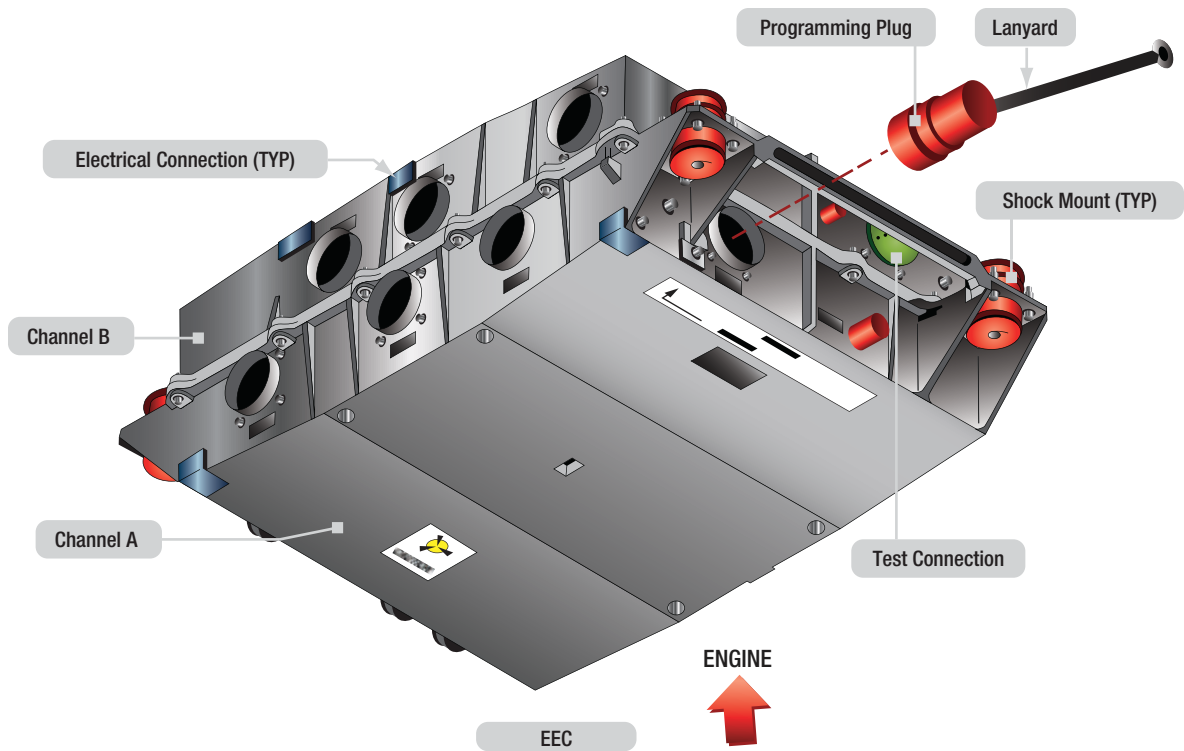

Figure 11-5. EEC and programming plug.

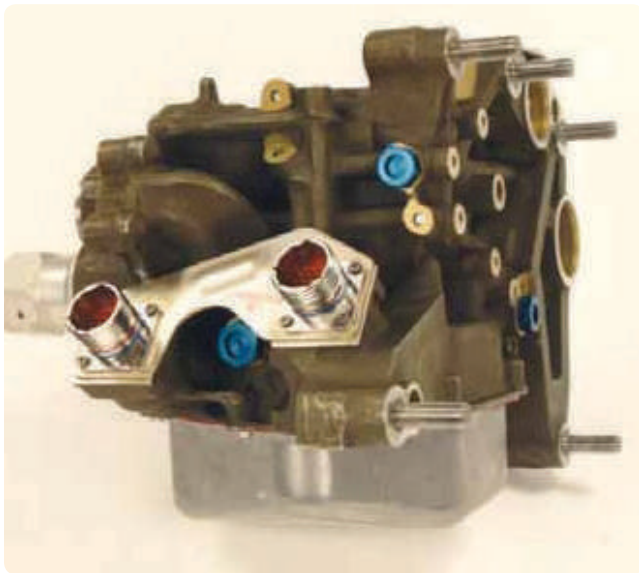

Figure 11-6. Fuel metering unit.



Figure 11-7. Fuel pump.

The EEC also sends a signal to the minimum pressure and shutoff valve in the fuel metering unit to start or stop fuel flow. The EEC receives position feedback for several engine components by using rotary differential transformer, linear variable differential transformer, and thermocouples. These sensors feed engine parameter information from several systems back to the EEC. The fuel control run cutoff switch controls the high pressure fuel shut off valve that allows or cuts off fuel

flow. The fuel temperature sensor thermocouple attaches to the fuel outlet line on the rear of the fuel/oil cooler and sends this information to the EEC. The EEC uses a torque motor driver to control the position of the metering valve in the fuel metering unit. The EEC uses solenoid drivers to control the other functions of the FMU. The EEC also controls several other subsystems of the engine, as shown in **Figure 11-8**, through torque motors and solenoids, such as fuel and air oil coolers, bleed valves, variable stator vanes, turbine cooling air valves, and the turbine case cooling system.

Each channel of the EEC has seven electrical connections, three on each side and one on the bottom. Both channels

share the inputs of the two connections on the top of the EEC. These are the programming plug and test connector. The programming plug selects the proper software in the EEC for the thrust rating of the engine. The plug attaches to the engine fan case with a lanyard. When removing the EEC, the plug remains with the engine. Each channel of the EEC has three pneumatic connections on the bottom of the EEC. Transducers inside the EEC supply the related and opposite EEC channel with a signal in proportion to the pressure.

The pressures that are read by the EEC are ambient pressure, burner pressure, LPC exit pressure, and fan inlet pressure. Each channel has its own wire color that connects the EEC to its sensors. Channel A wiring is blue and channel B sensor signals are green. The non-EEC circuit wire is gray while the thermocouple signals are yellow. This color coding helps simplify which sensors are used with each channel.

## FUEL SYSTEM OPERATION

The fuel pump receives fuel from the airplane fuel system. The low pressure boost stage of the pump pressurizes the fuel and sends it to the fuel/oil cooler (FOC). The fuel flows from the FOC, through the fuel pump filter element, and then to the high pressure main stage of the pump. The high pressure main stage increases the fuel pressure and sends it to the fuel metering unit (FMU). It also supplies servo fuel to the servo fuel heater and engine components. Fuel for combustion (metered fuel) goes through the fuel flow transmitter to the distribution valve. (Figure 11-9) The fuel distribution valve supplies metered fuel to the fuel supply manifolds. (Figure 11-10)

The fuel injectors get the metered fuel from the fuel supply manifolds and spray the fuel into the engine for combustion. (Figure 11-11) The fuel pump housing contains a disposable fuel filter element. The fuel filter differential pressure switch supplies a signal to the EEC that indicates an almost clogged filter condition. Unfiltered fuel can then bypass the filter element if the element becomes clogged.

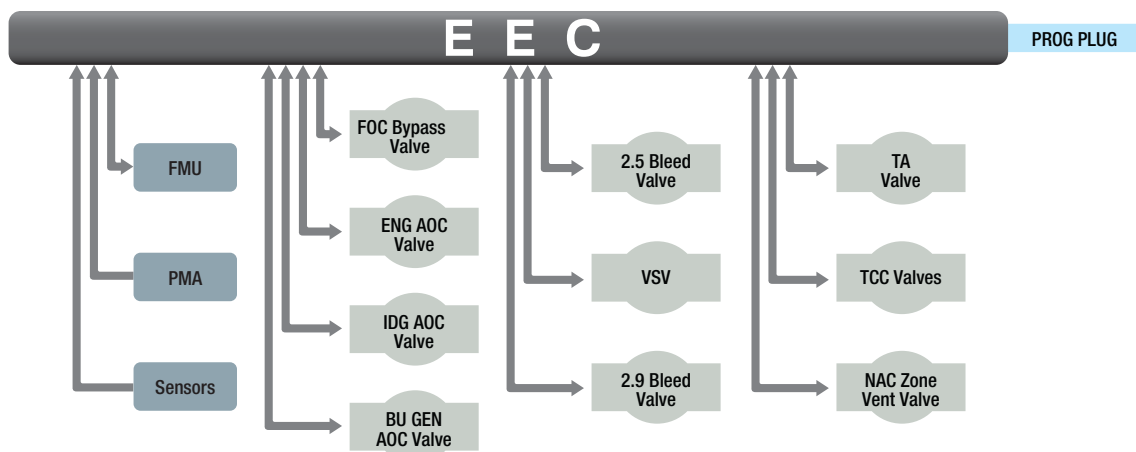

Figure 11-8. Systems controlled by EEC.

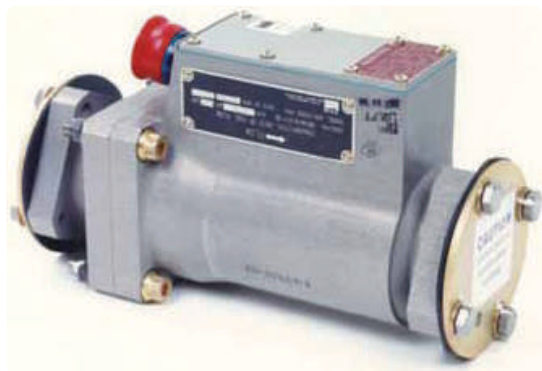

Figure 11-9. Fuel flow transmitter.



Figure 11-10. Fuel distribution valve.



Figure 11-11. Fuel manifolds.

## ENGINE FUEL SYSTEM COMPONENTS

### MAIN FUEL PUMPS (ENGINE DRIVEN)

Main fuel pumps deliver a continuous supply of fuel at the proper pressure and at all times during operation of the aircraft engine. The engine-driven fuel pump must be capable of delivering the maximum needed flow at appropriate pressure to obtain satisfactory nozzle spray and accurate fuel regulation. These engine driven fuel pumps may be divided into two distinct system categories:

1. Constant displacement
2. Non-constant displacement

Their use depends on where in the engine fuel system they are used. Generally, a non-positive displacement (centrifugal pump) is used at the inlet of the engine-driven pump to provide positive flow to the second stage of the pump. The output of a centrifugal pump can be varied as needed and is sometimes referred to as a boost stage of the engine-driven pump.

The second or main stage of the engine-driven fuel pump for turbine engines is generally a positive displacement type of pump. The term "positive displacement" means that the gear supplies a fixed quantity of fuel to the engine for every revolution of the pump gears. Gear-type pumps have approximately straight line flow characteristics, whereas fuel requirements fluctuate with flight or ambient air conditions. Hence, a pump of adequate capacity at all engine operating conditions has excess capacity over most of the range of operation. This is the characteristic that requires the use of a pressure relief valve for bypassing excess fuel back to the inlet. A typical two-stage turbine engine driven pump is illustrated in *Figure 11-12*.

The impeller, which is driven at a greater speed than the high pressure elements, increases the fuel pressure depending upon engine speed.

The fuel is discharged from the boost element (impeller) to the two high-pressure gear elements. A relief valve is incorporated in the discharge port of the pump. This valve opens at a predetermined pressure and is capable of bypassing the total fuel flow. This allows fuel in excess of that required for engine operation at the time to be recirculated. The bypass fuel is routed to the inlet side of the second stage pump. Fuel flows from the pump to the fuel metering unit or fuel control. The fuel control is often attached to the fuel pump. The fuel pump is also lubricated by the fuel passing through the pump, and it should never be turned without fuel flow supplied to the inlet of the pump. As the engine coasts down at shutdown, the fuel pump should be provided with fuel until it comes to a stop.



Figure 11-12. High pressure fuel pump of a M-601 turboprop engine manufactured by Jihostroj Technology.

## FUEL HEATER

Gas turbine engine fuel systems are very susceptible to the formation of ice in the fuel filters. When the fuel in the aircraft fuel tanks cools to 32 °F or below, residual water in the fuel tends to freeze, forming ice crystals. When these ice crystals in the fuel become trapped in the filter, they block fuel flow to the engine, which causes a very serious problem. To prevent this problem, the fuel is kept at a temperature above freezing. Warmer fuel also can improve combustion, so some means of regulating the fuel temperature is needed.

One method of regulating fuel temperature is to use a fuel heater which operates as a heat exchanger to warm the fuel. The heater can use engine bleed air or engine lubricating oil as a source of heat. The bleed air type is called an air-to-liquid exchanger and the oil type is known as a liquid-to-liquid heat exchanger. The function of a fuel heater is to protect the engine fuel system from ice formation. However, should ice form in the filter, the heater can also be used to thaw ice on the fuel screen to allow fuel to flow freely again. On most installations, the fuel filter is fitted with a pressure-drop warning switch, which illuminates a warning light on the cockpit instrument panel. If ice begins to collect on the filter surface, the pressure across the filter slowly decreases. When the pressure reaches a predetermined value, the warning light alerts the flight deck personnel.

Fuel deicing systems are designed to be used intermittently. The control of the system may be manual, by a switch in the cockpit, or automatic, using a thermostatic sensing element in the fuel heater to open or close the air or oil shutoff valve. A fuel heater system is shown in *Figure 11-13*. In a FADEC system, the computer controls the fuel temperature by sensing the fuel temperature and heating it as needed.

## FUEL FILTERS

A low-pressure filter is installed between the supply tanks and the engine fuel system to protect the engine-driven fuel pump and various control devices. An additional high-pressure fuel filter is installed between the fuel pump and the fuel control to protect the fuel control from contaminants that could come from the low pressure pump.

The three most common types of filters in use are the micron filter, the wafer screen filter, and the plain screen mesh filter. The individual use of each of these filters is dictated by the filtering treatment required at a particular location. The micron filter has the greatest filtering action of any present day filter type and, as the name implies, is rated in microns. (*Figure 11-14*) (A micron is one thousandth of 1 millimeter.) The porous cellulose material frequently used in construction of the filter cartridges is capable of removing foreign matter

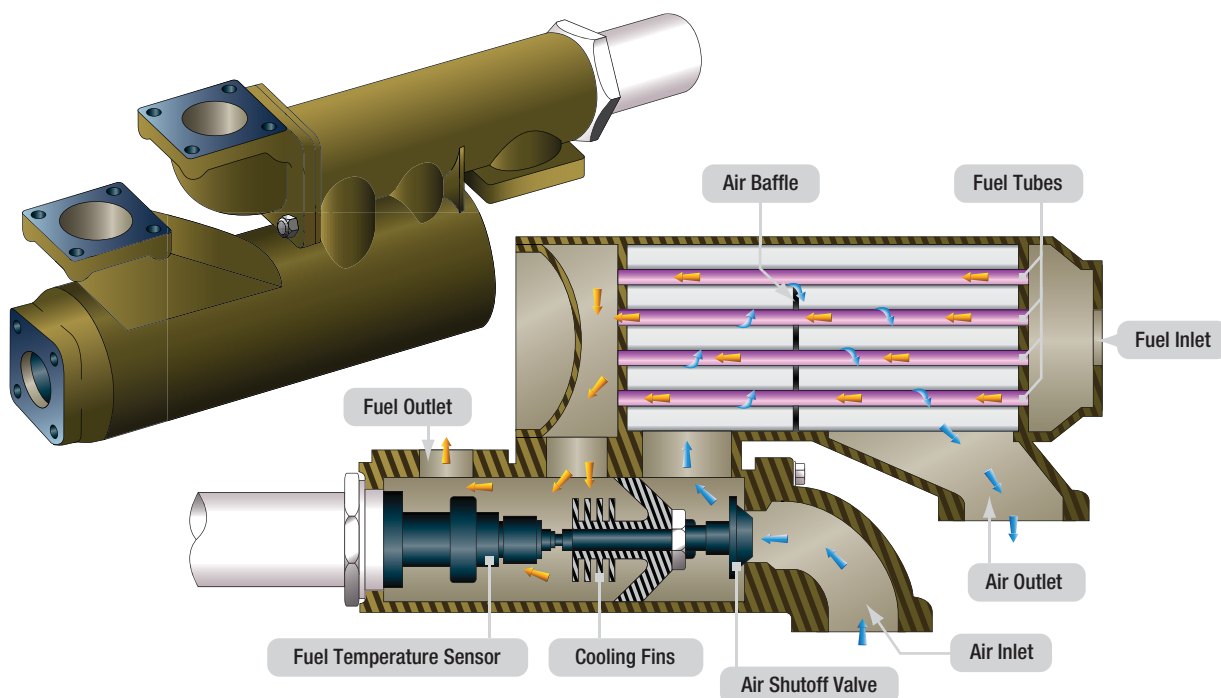

Figure 11-13. Fuel heater.

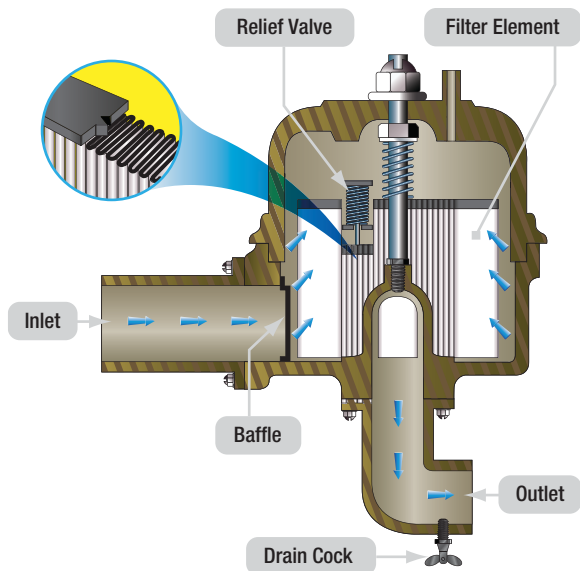

Figure 11-14. Aircraft fuel filter.

measuring from 10–25 microns. The minute openings make this type of filter susceptible to clogging; therefore, a bypass valve is a necessary safety factor.

Since the micron filter does such a thorough job of removing foreign matter, it is especially valuable between the fuel tank and engine. The cellulose material also absorbs water, preventing it from passing through the pumps. If water does seep through the filter, which happens occasionally when filter elements become saturated with water, the water can and does quickly damage the working elements of the fuel pump and control units, since these elements depend solely on the fuel for their lubrication. To reduce water damage

to pumps and control units, periodic servicing and replacement of filter elements is imperative. Daily draining of fuel tank sumps and low-pressure filters eliminates much filter trouble and undue maintenance of pumps and fuel control units.

The most widely used filters are the 200-mesh and the 35-mesh micron filters. They are used in fuel pumps, fuel controls, and between the fuel pump and fuel control where removal of micronic particles is needed. These filters, usually made of fine-mesh steel wire, are a series of layers of wire. The wafer screen type of filter has a replaceable element, which is made of layers of screen disks of bronze, brass, steel, or similar material. (Figure 11-15) This type of filter is capable of removing micronic particles. It also has the strength to withstand high pressure.

## FUEL SPRAY NOZZLES AND FUEL MANIFOLDS

Although fuel spray nozzles are an integral part of the fuel system, their design is closely related to the type of combustion chamber in which they are installed. The fuel nozzles inject fuel into the combustion area in a highly atomized, precisely patterned spray so that burning is completed evenly, in the shortest possible time, and in the smallest possible space. It is very important that the fuel be evenly distributed and well centered in the flame area within the liners. This is to preclude the formation of any hot spots in the combustion chambers and to prevent the flame burning through the liner.

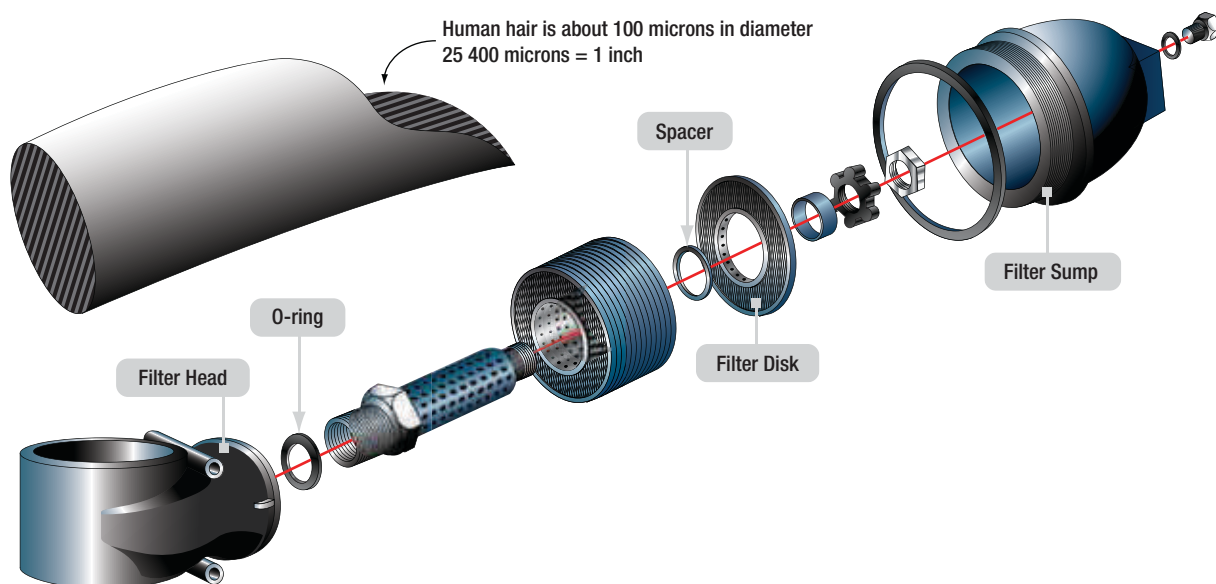

Figure 11-15. Wafer screen filter.

Fuel nozzle types vary considerably between engines, although for the most part fuel is sprayed into the combustion area under pressure through small orifices in the nozzles. The two types of fuel nozzles generally used are the simplex and the duplex configurations. The duplex nozzle usually requires a dual manifold and a pressurizing valve or flow divider for dividing primary and secondary (main) fuel flow, but the simplex nozzle requires only a single manifold for proper fuel delivery.

The fuel nozzles can be constructed to be installed in various ways. The two methods used quite frequently are:

1. External mounting wherein a mounting pad is provided for attachment of the nozzles to the case or the inlet air elbow, with the nozzle near the dome; or
2. Internal mounting at the liner dome, in which the chamber cover must be removed for replacement or maintenance of the nozzle.

The nozzles used in a specific engine should be matched so that they flow equal amounts of fuel. Even fuel distribution is important to efficient combustion in the burner section. The fuel nozzle must present a fine spray with the correct pattern and optimum atomization.

### SIMPLEX FUEL NOZZLE

The simplex fuel nozzle was the first nozzle type used in turbine engines and was replaced in most installations with the duplex nozzle, which gave better atomization at starting and idling speeds. The simplex nozzle is still being used in several installations. (*Figure 11-16*) Each of the simplex nozzles consists of a nozzle tip, an insert, and a strainer made up of fine-mesh screen and a support.

### DUPLEX FUEL NOZZLE

The duplex fuel nozzle is widely used in present day gas turbine engines. As mentioned previously, its use requires a flow divider, but at the same time it offers a desirable spray pattern for combustion over a wide range of operating pressures. (*Figure 11-17*) A nozzle typical of this type is illustrated in *Figure 11-18*.

### AIRBLAST NOZZLES

Airblast nozzles are used to provide improved mixing of the fuel and airflow to provide an optimum spray for combustion. Squirrel vanes are used to mix the air and fuel at the nozzle opening. By using a



Figure 11-16. Simplex airblast nozzle cutaway.

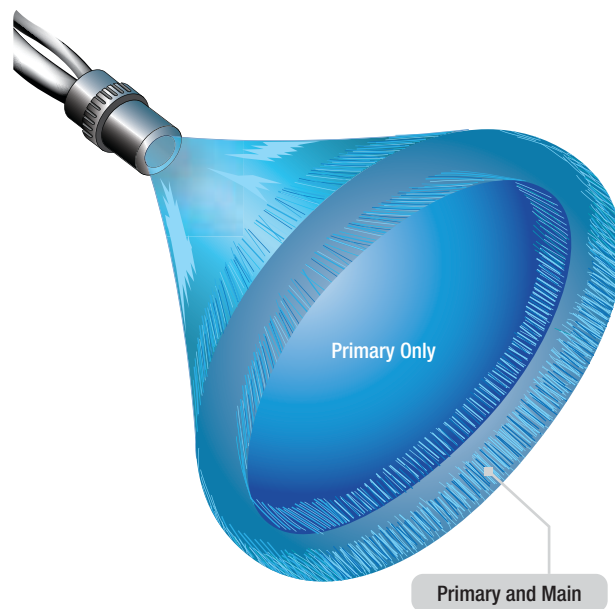

Figure 11-17. Duplex nozzle spray pattern.

proportion of the primary combustion airflow in the fuel spray, locally rich fuel concentrations can be reduced. This type of fuel nozzle can be either simplex or duplex, depending upon the engine. This nozzle type can operate at lower working pressures than other nozzles which allows for lighter pumps. This airblast nozzle also helps in reducing the tendency of the nozzle to carbon up which can disturb the flow pattern.



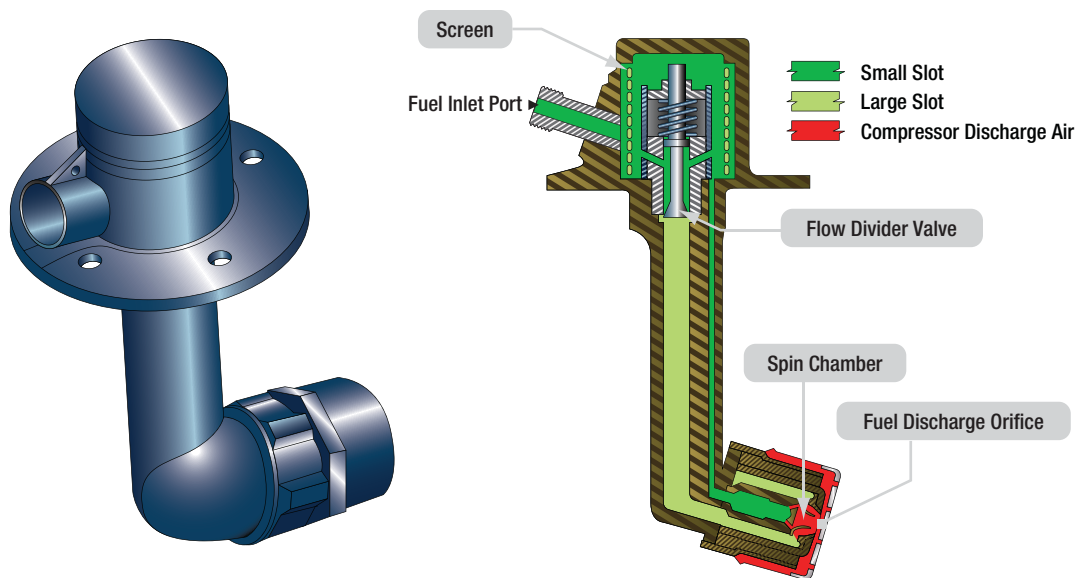

Figure 11-18. Duplex fuel nozzle.

### FLOW DIVIDER

A flow divider creates primary and secondary fuel supplies that are discharged through separate manifolds, providing two separate fuel flows. (Figure 11-19) Metered fuel from the fuel control enters the inlet of the flow divider and passes through an orifice and then on to the primary nozzles. A passage in the flow divider directs fuel flow from both sides of the orifice to a chamber. This chamber contains differential pressure bellows, a viscosity compensated restrictor (VCR), and a surge dampener. During engine start, fuel pressure is applied to the inlet port and across the VCR, surge dampener, and on to the primary side of the nozzles. Fuel is also applied under pressure to the outside of the flow divider bellows and through the surge dampener to the inside of the flow divider bellows. This unequal pressure causes the flow divider valve to remain closed.

When fuel flow increases, the differential pressure on the bellows also increases. At a predetermined pressure, the bellows compresses, allowing the flow divider valve to open. This action starts fuel flow to the secondary manifold, which increases the fuel flow to the engine. This fuel flows out of the secondary opening in the nozzles.

### FUEL PRESSURIZING AND DUMP VALVES

The fuel pressurizing valve is usually required on engines incorporating duplex fuel nozzles to divide the flow into primary and secondary manifolds. At the fuel flows required for starting and altitude idling, all



Figure 11-19. Flow divider.

the fuel passes through the primary line. As the fuel flow increases, the valve begins to open the main line until at maximum flow the secondary line is passing approximately 90 percent of the fuel.

Fuel pressurizing valves usually trap fuel forward of the manifold, giving a positive cutoff. This cutoff prevents fuel from dribbling into the manifold and through the fuel nozzles, limiting afterfires and carbonization of the fuel nozzles. Carbonization occurs because combustion chamber temperatures are lowered and the fuel is not completely burned.

A flow divider performs essentially the same function as a pressurizing valve. It is used, as the name implies, to divide flow to the duplex fuel nozzles. It is not unusual for units performing identical functions to have different nomenclature between engine manufacturers.

## COMBUSTION DRAIN VALVES

The drain valves are units used for draining fuel from the various components of the engine where accumulated fuel is most likely to present operating problems. The possibility of combustion chamber accumulation with the resultant fire hazard is one problem. A residual problem is the deposit of lead and/or gum, after evaporation, in such places as fuel manifolds and fuel nozzles.

In some instances, the fuel manifolds are drained by an individual unit known as a drip or dump valve. This type of valve may operate by pressure differential, or it may be solenoid operated. The combustion chamber drain valve drains fuel that accumulates in the combustion chamber after each shutdown and fuel that may have accumulated during a false start. If the combustion chambers are the can type, fuel drains by gravity down through the flame tubes or interconnector tubes until it gathers in the lower chambers which are fitted with drain lines to the drain valve. If the combustion chamber is of the basket or annular type, the fuel merely drains through the air holes in the liner and accumulates in a trap in the bottom of the chamber housing which is connected to the drain line.

After the fuel accumulates in the bottom of the combustion chamber or drain lines, the drain valve allows the fuel to be drained whenever pressure within the manifold or the burner(s) has been reduced to near atmospheric pressure. A small spring holds the valve off its seat until pressure in the combustion chamber during operation overcomes the spring and closes the valve. The valve is closed during engine operation. It is imperative that this valve be in good working condition to drain accumulated fuel after each shutdown. Otherwise, a hot start during the next starting attempt or an afterfire after shutdown is likely to occur.

## FUEL QUANTITY INDICATING UNITS

Fuel quantity units vary from one installation to the next. A fuel counter or indicator, mounted on the instrument panel, is electrically connected to a flowmeter installed in the fuel line to the engine.

The fuel counter, or totalizer, is used to keep record of fuel use. When the aircraft is serviced with fuel, the counter is manually set to the total number of pounds of fuel in all tanks. As fuel passes through the measuring element of the flowmeter, it sends electrical impulses to the fuel counter. These impulses actuate the fuel counter mechanism so that the number of pounds passing to the engine is subtracted from the original reading. Thus, the fuel counter continually shows the total quantity of fuel, in pounds, remaining in the aircraft. However, there are certain conditions that cause the fuel counter indication to be inaccurate. Any jettisoned fuel is indicated on the fuel counter as fuel still available for use. Any fuel that leaks from a tank or a fuel line upstream of the flowmeter is not counted.



*Question:* 11-1

What two controllable variables affect the selection of thrust on a turboprop aircraft?

*Question:* 11-5

The minute openings of turbine engine fuel filters make it susceptible to clogging; therefore, a \_\_\_\_\_ is incorporated as a safety factor.

*Question:* 11-2

FADEC stand for \_\_\_\_\_.

*Question:* 11-6

To prevent hot starts or an after fire after engine shutdown, a \_\_\_\_\_ is located in the combustion section of a turbine engine.

*Question:* 11-3

A \_\_\_\_\_ supplies a signal to the EEC that indicates an almost clogged filter condition.

*Question:* 11-7

Fuel heaters are required to warm fuel above \_\_\_\_\_ degrees for the for primary purpose of \_\_\_\_\_?

*Question:* 11-4

The main fuel pump on a turbine engine is \_\_\_\_\_ driven.

*Question:* 11-8

Duplex fuel nozzles are preferable to the older simplex type because the provide a superior \_\_\_\_\_?

## ANSWERS

*Answer:* 11-1

fuel flow.  
propeller blade angle.

*Answer:* 11-5

bypass valve.

*Answer:* 11-2

Full Authority Digital Electronic Control.

*Answer:* 11-6

drain valve.

*Answer:* 11-3

fuel filter differential pressure switch.

*Answer:* 11-7

32 degrees °F (0 degrees °C); ice prevention of water in the fuel.

*Answer:* 11-4

engine.

*Answer:* 11-8

Spray pattern and atomization.



# GAS TURBINE ENGINE

## AIR SYSTEMS

### SUB-MODULE 12

PART-66 SYLLABUS LEVELS

CERTIFICATION CATEGORY →

A1	B1
1	2

#### Sub-Module 12 AIR SYSTEMS

##### Knowledge Requirements

#### 15.12 - Air Systems

Operation of engine air distribution and anti-ice control systems, including internal cooling, sealing and external air services.

#### Level 1

A familiarization with the principal elements of the subject.

##### Objectives:

- (a) The applicant should be familiar with the basic elements of the subject.
- (b) The applicant should be able to give a simple description of the whole subject, using common words and examples.
- (c) The applicant should be able to use typical terms.

#### Level 2

A general knowledge of the theoretical and practical aspects of the subject and an ability to apply that knowledge.

##### Objectives:

- (a) The applicant should be able to understand the theoretical fundamentals of the subject.
- (b) The applicant should be able to give a general description of the subject using, as appropriate, typical examples.
- (c) The applicant should be able to use mathematical formula in conjunction with physical laws describing the subject.
- (d) The applicant should be able to read and understand sketches, drawings and schematics describing the subject.
- (e) The applicant should be able to apply his knowledge in a practical manner using detailed procedures.

---

## AIR SYSTEMS

### TURBINE ENGINE COOLING

The intense heat generated when fuel and air are burned necessitates that some means of cooling be provided for all internal combustion engines. Reciprocating engines are cooled either by passing air over fins attached to the cylinders or by passing a liquid coolant through jackets that surround the cylinders. The cooling problem is made easier because combustion occurs only during every fourth stroke of a four stroke-cycle engine.

The burning process in a gas turbine engine is continuous, and nearly all of the cooling air must be passed through the inside of the engine. If only enough air were admitted to the engine to provide an ideal air/fuel ratio of 15:1, internal temperatures would increase to more than 4 000 °F. In practice, a large amount of air in excess of the ideal ratio is admitted to the engine. The large surplus of air cools the hot sections of the engine to acceptable temperatures ranging from 1 500° to 2 100 °F.

Because of the effect of cooling, the temperatures of the outside of the case are considerably less than those encountered within the engine. The hottest area occurs in and around the turbines. Although the gases have begun to cool a little at this point, the conductivity of the metal in the case carries the heat directly to the outside skin.

Secondary air passing through the engine cools the combustion-chamber liners. The liners are constructed to induce a thin, fast-moving film of air over both the inner and outer surfaces of the liner. Can-annular-type burners frequently are provided with a center tube to lead cooling air into the center of the burner to promote high combustion efficiency and rapid dilution of the hot combustion gases while minimizing pressure losses. In all types of gas turbines, large amounts of relatively cool air join and mix with the burned gases aft of the burners to cool the hot gases just before they enter the turbines.

The exhaust turbine bearing is the most critical lubricating point in a gas turbine engine because of the high temperature normally present. In some engines, air cooling is used in addition to oil cooling the bearing, which supports the turbine. Secondary air flow for cooling is provide by bleeding air from the early stages of the compressor. It is used to cool turbine disk, vanes, and blades as well as the exhaust bearing.

Additionally, some turbine wheels may have bleed air flowing over the turbine disk, which reduces heat radiation to the bearing surface.

Cooling-air inlets are frequently provided around the exterior of the engine to permit the entrance of air to cool the turbine case, the bearings, and the turbine nozzle. Internal air is bled from the engine compressor section and is vented to the bearings and other parts of the engine. Air vented into or from the engine is ejected into the exhaust stream. When located on the side of the engine, the case is cooled by outside air flowing around it. The engine exterior and the engine nacelle are cooled by passing fan air around the engine and the nacelle. The engine compartment frequently is divided into two sections.

The forward section is referred to as the cold section and the aft section (turbine) is referred to as the hot section. Case drains drain most potential leaks overboard to prevent fluids from building up in the nacelle.

### ACCESSORY ZONE COOLING

Turbine powerplants can be divided into primary zones that are isolated from each other by fireproof bulkheads and seals. The zones are the fan case compartment, intermediate compressor case compartment, and the core engine compartment. (*Figure 12-1*)

Calibrated airflows are supplied to the zones to keep the temperatures around the engine at levels that are acceptable. The airflow provides for proper ventilation to prevent a buildup of any harmful vapors.

*Zone 1* is around the fan case that contains the accessory case and the electronic engine control (EEC). This area is vented by using ram air through an inlet in the nose cowl and is exhausted through a louvered vent in the right fan cowling. If the pressure exceeds a certain limit, a pressure relief door opens and relieves the pressure.

*Zone 2* is cooled by fan air from the upper part of the fan duct and is exhausted at the lower end back into the fan air stream. This area has both fuel and oil lines, so removing any unwanted vapors would be important.

*Zone 3* is the area around the high-pressure compressor to the turbine cases. This zone also contains fuel and oil

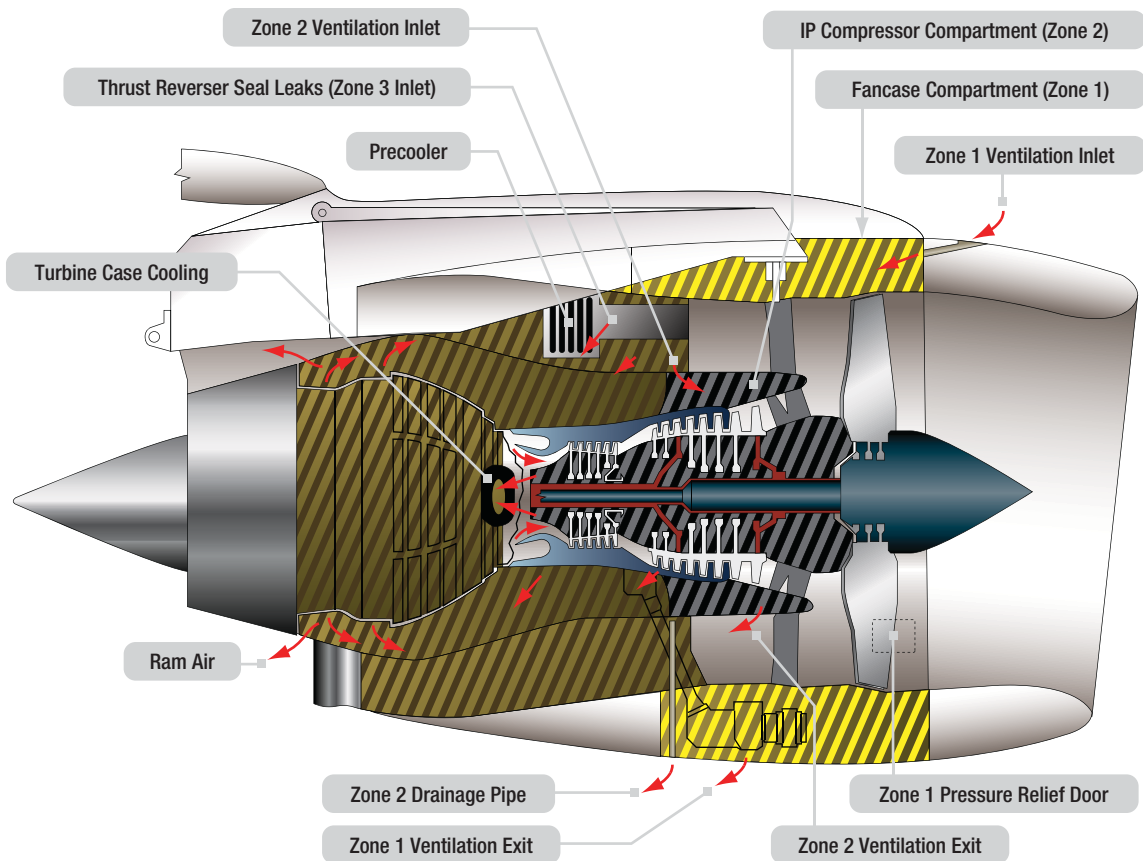

Figure 12-1. Accessory zone cooling.

lines and other accessories. Air enters from the exhaust of the precooler and other areas and is exhausted from the zone through the aft edge of the thrust reverser inner wall and the turbine exhaust sleeve.

A secondary function of the compressor is to supply air for various purposes on the aircraft. Bleed air can be taken from any of the various pressure stages of the compressor. The exact location of the bleed ports is dependent on the pressure or temperature required for a particular job. The ports are small openings in the compressor case adjacent to the particular stage from which the air is to be bled. Varying degrees of pressure are available by tapping into the appropriate stage. Air is often bled from the final or highest pressure stage since, at this point, pressure and air temperature are at a maximum. At times it may be necessary to cool this high-pressure air. If it is used for cabin pressurization or other purposes to which excess heat would be uncomfortable or detrimental, the air is sent through an air conditioning unit before it enters the cabin.

Bleed air is utilized in a wide variety of ways. Some engine bleed air external air services include:

1. Cabin pressurization, heating, and cooling;
2. Deicing and anti-icing equipment;
3. Pneumatic starting of engines; and
4. Auxiliary drive units (ADU).

**ANTI-ICE CONTROL SYSTEMS**

An anti-ice control system is a particularly important use for bleed air. The engine and airframe both require anti-icing. Electrical and chemical anti-ice systems are common and well-suited for small aircraft. However, the size of transport category aircraft make these methods impractical. Bleed air routed through a shutoff valve controlled from the flight deck is ducted to areas of the aircraft prone to icing. The warm air flowing just behind surfaces such as the engine inlet and wing leading edges provides enough heat to prevent ice from forming. A thorough discussion of anti-icing systems is found in Module 11 of this textbook series.





**Question:** 12-1

The air that passes through a turbine engine to cool the combustion chamber liner is known as \_\_\_\_\_ air.

**Question:** 12-3

Name three uses of compressor bleed air on a turbine powered aircraft.

**Question:** 12-2

A secondary function of a turbine engine compressor is to supply \_\_\_\_\_ air for various purposes on the aircraft.

**Question:** 12-4

How is bleed-air pressure regulated to suit the needs of its various uses?

## ANSWERS

*Answer:* 12-1  
secondary.

*Answer:* 12-2  
bleed.

*Answer:* 12-3  
Cabin pressurization, heating, and cooling.  
Deicing and anti icing equipment.  
Pneumatic starting of engines.  
Auxiliary drive units.

*Answer:* 12-4  
By selecting the stage of the compressor from where it  
is drawn.



# GAS TURBINE ENGINE

## STARTING AND IGNITION SYSTEMS

### SUB-MODULE 13

PART-66 SYLLABUS LEVELS

CERTIFICATION CATEGORY →

A1	B1
1	2

STARTING AND IGNITION SYSTEMS

#### Sub-Module 13 STARTING AND IGNITION SYSTEMS

Knowledge Requirements

##### 15.13 - Starting and Ignition Systems

- Operation of engine start systems and components;
- Ignition systems and components;
- Maintenance safety requirements.

#### Level 1

A familiarization with the principal elements of the subject.

##### Objectives:

- (a) The applicant should be familiar with the basic elements of the subject.
- (b) The applicant should be able to give a simple description of the whole subject, using common words and examples.
- (c) The applicant should be able to use typical terms.

#### Level 2

A general knowledge of the theoretical and practical aspects of the subject and an ability to apply that knowledge.

##### Objectives:

- (a) The applicant should be able to understand the theoretical fundamentals of the subject.
- (b) The applicant should be able to give a general description of the subject using, as appropriate, typical examples.
- (c) The applicant should be able to use mathematical formula in conjunction with physical laws describing the subject.
- (d) The applicant should be able to read and understand sketches, drawings and schematics describing the subject.
- (e) The applicant should be able to apply his knowledge in a practical manner using detailed procedures.

## STARTING SYSTEMS

### GAS TURBINE ENGINE STARTERS

Gas turbine engines are started by rotating the high-pressure compressor. To start a gas turbine engine, it is necessary to accelerate the compressor to provide sufficient air to support combustion in the combustion section, or burners. Once ignition and fuel has been introduced and the light-off has occurred, the starter must continue to assist the engine until the engine reaches a self-sustaining speed. The torque supplied by the starter must be in excess of the torque required to overcome compressor inertia and the friction loads of the engine's compressor.

*Figure 13-1* illustrates a typical starting sequence for a gas turbine engine, regardless of the type of starter employed. As soon as the starter has accelerated the compressor sufficiently to establish airflow through the engine, the ignition is turned on followed by the fuel.

The exact sequence of the starting procedure is important since there must be sufficient airflow through the engine to support combustion before the fuel-air mixture is ignited. At low engine cranking speeds, the fuel flow rate is not sufficient to enable the engine to accelerate; for this reason, the starter continues to crank the engine until after self-accelerating speed has been attained. If assistance from the starter were cut off below the self-accelerating speed, the engine would either fail to accelerate to idle speed or might even decelerate because it could not produce sufficient energy to sustain rotation or to accelerate during the initial phase of the starting cycle. The starter must continue to assist the engine considerably above the self-accelerating speed to avoid a delay in the starting cycle, which would result in a hot or hung false start or a combination of both. At the proper points in the sequence, the starter and ignition are automatically cut off. The basic types of starters that are in current use for gas turbine engines are direct current (DC) electric motor, starter/generators, and the air turbine type of starters.

Many types of turbine starters have included several different methods for turning the engine for starting. Several methods have been used but most of these have given way to electric or air turbine starters. An air impingement starting system, which is sometimes used on small engines, consists of jets of compressed air piped

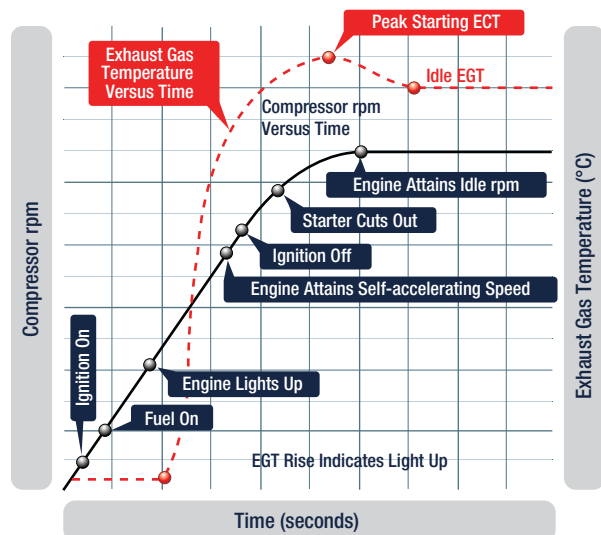

Figure 13-1. Typical gas turbine engine starting sequence.

to the inside of the compressor or turbine case so that the jet air blast is directed onto the compressor or turbine rotor blades, causing them to rotate.

### CARTRIDGE PNEUMATIC STARTERS

A typical cartridge/pneumatic turbine engine starter may be operated as an ordinary air turbine starter from a ground operated air supply or an engine cross-bleed source. It may also be operated as a cartridge starter. (*Figure 13-2*) To accomplish a cartridge start, a cartridge is first placed in the breech cap. The breech is then closed on the breech chamber by means of the breech handle and then rotated a partial turn to engage the lugs between the two breech sections. The cartridge is ignited by applying voltage through the connector at the end of the breech handle. Upon ignition, the cartridge begins to generate gas.

The gas is forced out of the breech to the hot gas nozzles that are directed toward the buckets on the turbine rotor, and rotation is produced via the overboard exhaust collector. Before reaching the nozzle, the hot gas passes an outlet leading to the relief valve. This valve directs hot gas to the turbine, bypassing the hot gas nozzle, as the pressure rises above the preset maximum. Thus, the pressure of the gas within the hot gas circuit is maintained at the optimum level.

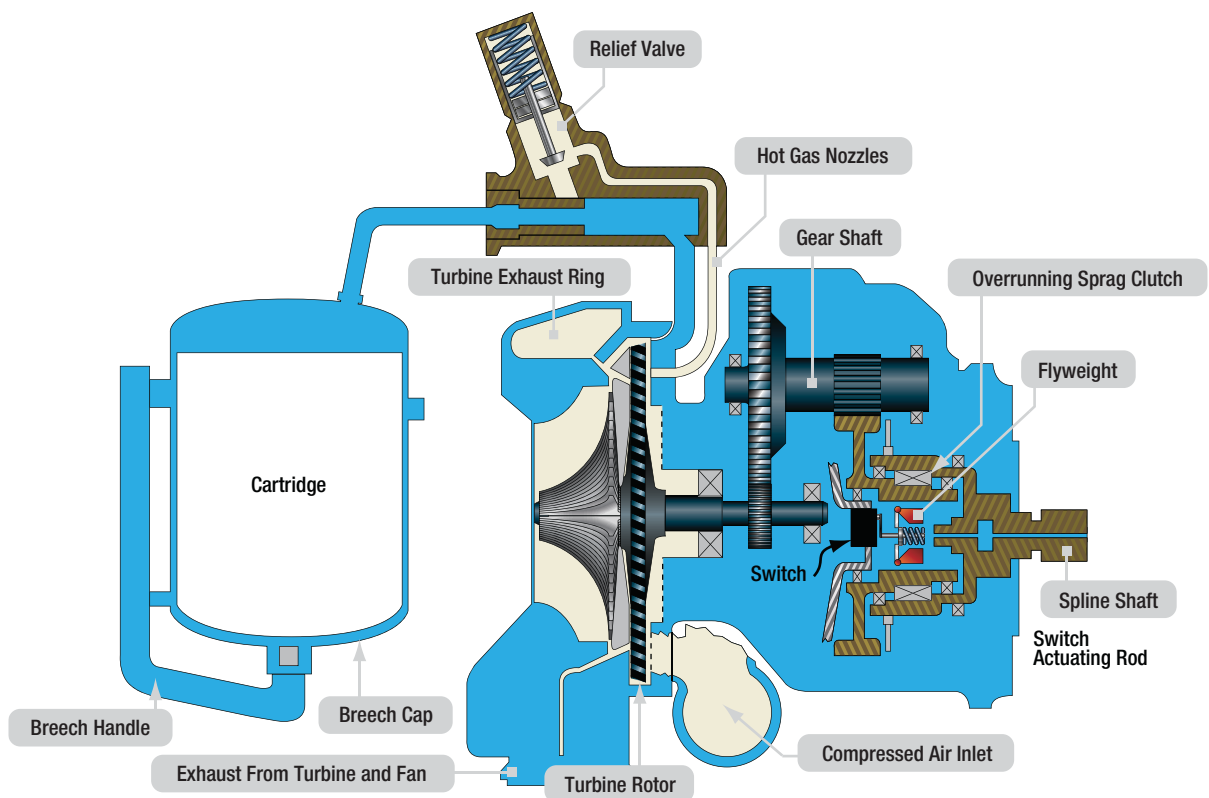

Figure 13-2. Cartridge/pneumatic starter schematic.

The fuel/air combustion starter was used to start gas turbine engines by using the combustion energy of jet A fuel and compressed air. The starter consists of a turbine-driven power unit and auxiliary fuel, air, and ignition systems. Operation of this type starter is, in most installations, fully automatic; actuation of a single switch causes the starter to fire and accelerate the engine from rest to starter cutoff speed.

Hydraulic pumps and motors have also been used for some smaller engines. Many of these systems are not often used on modern commercial aircraft because of the high power demands required to turn the large turbofan engines during the starting cycle on transport aircraft.

### ELECTRIC STARTING SYSTEMS AND STARTER GENERATOR STARTING SYSTEMS

Electric starting systems for gas turbine aircraft are of two general types: direct cranking electrical systems and starter generator systems. Direct cranking electric starting systems are used mostly on small turbine engines, such as Auxiliary Power Units (APUs), and some small turboshaft engines. Many gas turbine aircraft are equipped with starter/generator systems. Starter/generator starting systems are also similar to direct cranking electrical systems except that after

functioning as a starter, they contain a second series of windings that allow it to switch to a generator after the engine has reached a self-sustaining speed. This saves weight and space on the engine.

The starter/generator is permanently engaged with the engine shaft through the necessary drive gears, while the direct cranking starter must employ some means of disengaging the starter from the shaft after the engine has started. The starter/generator unit is basically a shunt generator with an additional heavy series winding. (*Figure 13-3*) This series winding is electrically connected to produce a strong field and a resulting high torque for starting. Starter/generator units are desirable from an economical standpoint, since one unit performs the functions of both starter and generator. Additionally, the total weight of starting system components is reduced and fewer spare parts are required.

The starter generator internal circuit has four field windings: a series field (C field), a shunt field, a compensating field, and an interpole or commutating winding. (*Figure 13-4*) During starting, the C field, compensating, and commutating windings are used. The unit is similar to a direct cranking starter since all of the windings used during starting are in series with

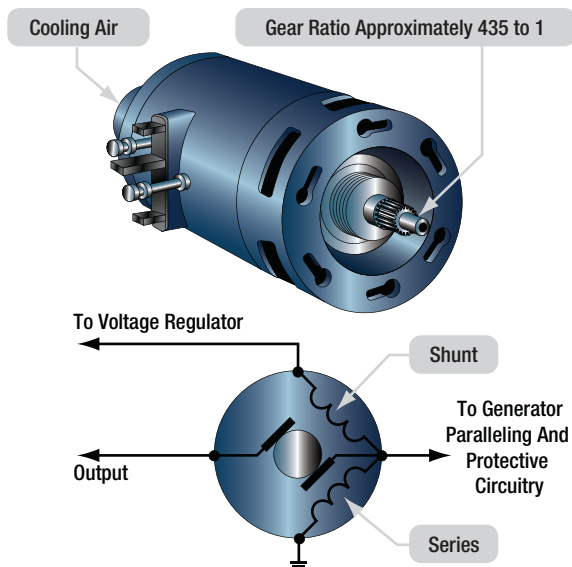

Figure 13-3. Typical starter generator.

the source. While acting as a starter, the unit makes no practical use of its shunt field. A source of 24 volts and 1 500 peak amperes is usually required for starting.

When operating as a generator, the shunt, compensating, and commutating windings are used. The C field is used only for starting purposes. The shunt field is connected in the conventional voltage control circuit for the generator. Compensating and commutating or interpole windings provide almost sparkless commutation from no load to full load. **Figure 13-5** illustrates the external circuit of a starter generator with an undercurrent controller. This unit controls the starter/generator when it is used as a starter. Its purpose is to assure positive action of the starter and to keep it operating until the engine is rotating fast enough to sustain combustion. The control block of the undercurrent controller contains two relays. One is the motor relay that controls the input to the starter. The other, the undercurrent relay, controls the operation of the motor relay.

The sequence of operation for the starting system is discussed in the following paragraphs. (**Figure 13-5**) To start an engine equipped with an undercurrent relay, it is first necessary to close the engine master switch. This completes the circuit from the aircraft's bus to the start switch, to the fuel valves, and to the throttle relay. Energizing the throttle relay starts the fuel pumps, and completing the fuel valve circuit gives the necessary fuel pressure for starting the engine. As the battery and start switch is turned on, three relays close: the motor relay, ignition relay, and battery cutout relay. The motor relay

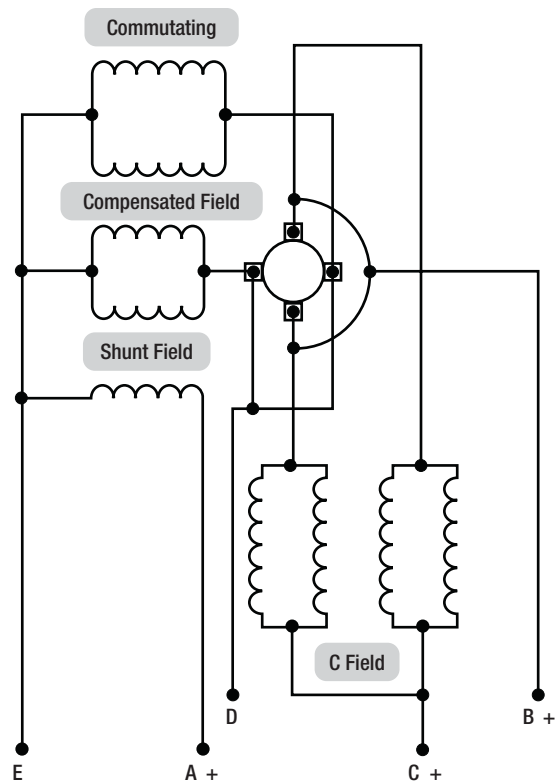

Figure 13-4. Starter generator internal circuit.

closes the circuit from the power source to the starter motor. The ignition relay closes the circuit to the ignition units. The battery cutout relay disconnects the battery.

Opening the battery circuit is necessary because the heavy drain of the starter motor would damage the battery. Closing the motor relay allows a very high current to flow to the motor. Since this current flows through the coil of the undercurrent relay, it closes. Closing the undercurrent relay completes a circuit from the positive bus to the motor relay coil, ignition relay coil, and battery cutout relay coil. The start switch is allowed to return to its normal off position, and all units continue to operate.

As the motor builds up speed, the current draw of the motor begins to decrease. As it decreases to less than 200 amps, the undercurrent relay opens. This action breaks the circuit from the positive bus to the coils of the motor, ignition, and battery cutout relays. The de-energizing of these relay coils halts the start operation. After these procedures are completed, the engine should be operating efficiently and ignition should be self-sustaining. If, however, the engine fails to reach sufficient speed to halt the starter operation, the stop switch may be used to break the circuit from the positive bus to the main contacts of the undercurrent relay.

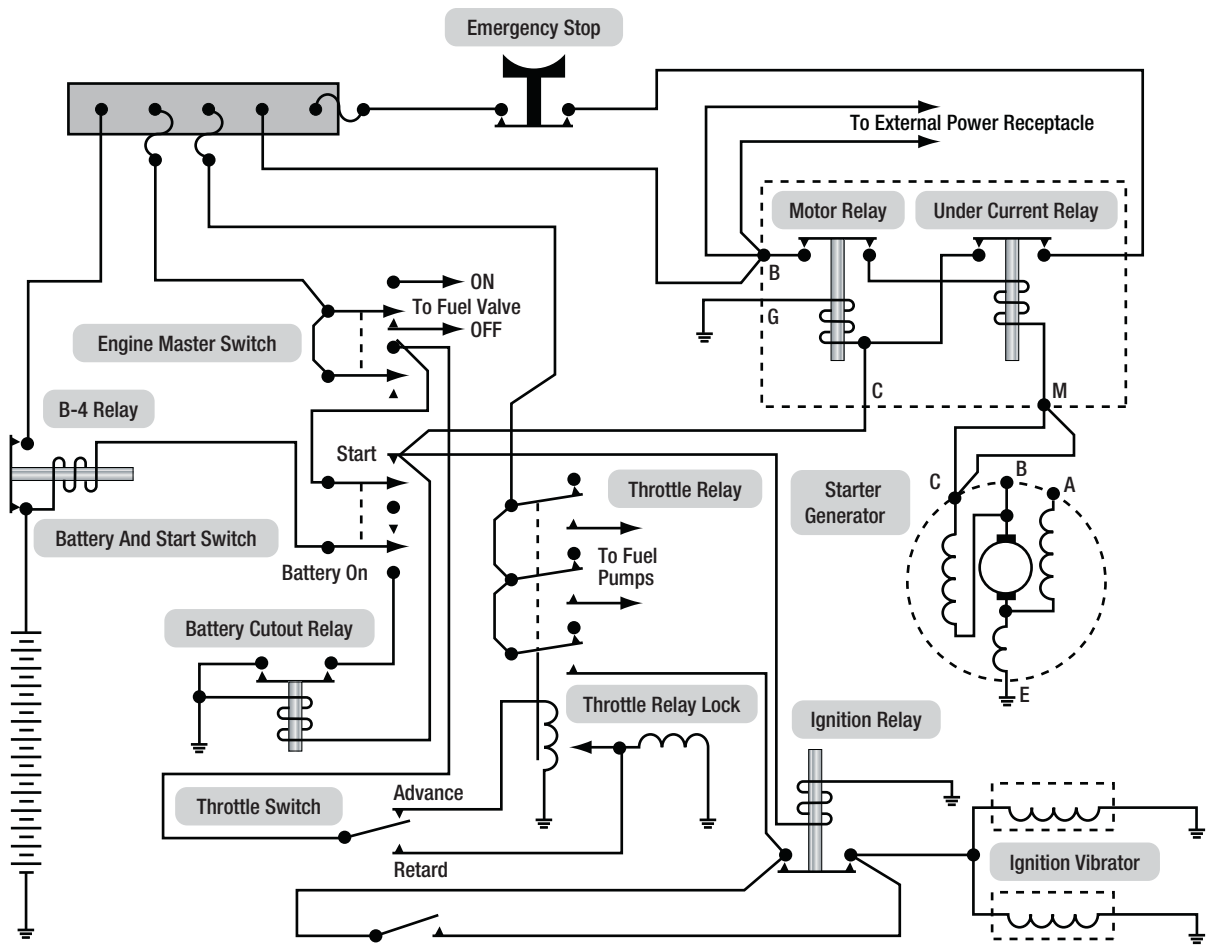

Figure 13-5. Starter generator circuit.

### TROUBLESHOOTING A STARTER GENERATOR STARTING SYSTEM

The procedures listed in *Figure 13-6* are typical of those used to repair malfunctions in a starter generator starting system similar to the system described in this section. These procedures are presented as a guide only. The appropriate manufacturer's instructions and approved maintenance directives should always be consulted for the aircraft involved.

### AIR TURBINE STARTERS

Air turbine starters are designed to provide high starting torque from a small, lightweight source. The typical air turbine starter weighs from one-fourth to one-half as much as an electric starter capable of starting the same engine. It is capable of developing considerable more torque than the electric starter.

The typical air turbine starter consists of an axial flow turbine that turns a drive coupling through a reduction gear train and a starter clutch mechanism. The air to operate an air turbine starter is supplied from either a

ground-operated air cart, the APU, or a cross-bleed start from an engine already operating. (*Figure 13-7*) Only one source of around 30–50 pounds per square inch (psi) is used at a time to start the engines. The pressure in the ducts must be high enough to provide for a complete start with a normal limit minimum of about 30 psi. When starting engines with an air turbine starter, always check the duct pressure prior to the start attempt.

*Figure 13-8* is a cutaway view of an air turbine starter. The starter is operated by introducing air of sufficient volume and pressure into the starter inlet. The air passes into the starter turbine housing where it is directed against the rotor blades by the nozzle vanes causing the turbine rotor to turn. As the rotor turns, it drives the reduction gear train and clutch arrangement, which includes the rotor pinion, planet gears and carrier, sprag clutch assembly, output shaft assembly, and drive coupling. The sprag clutch assembly engages automatically as soon as the rotor starts to turn, but disengages as soon as the drive coupling turns more rapidly than the rotor side. When the starter reaches



Starter Generator Starting System Troubleshooting Procedures		
Probable Cause	Isolation Procedure	Remedy
<b>Engine Does Not Rotate During Start Attempt</b>		
<ul style="list-style-type: none"> <li>• Low supply voltage to the starter</li> <li>• Power switch is defective</li> <li>• Ignition switch in throttle quadrant</li> <li>• Start-lockout relay is defective</li> <li>• Battery series relay is defective</li> <li>• Starter relay is defective</li> <li>• Defective starter</li> <li>• Start lock-in relay defective</li> <li>• Starter drive shaft in component drive gearbox is sheared</li> </ul>	<ul style="list-style-type: none"> <li>• Check voltage of the battery or external power source.</li> <li>• Check switch for continuity.</li> <li>• Check switch for continuity.</li> <li>• Check position of generator control switch.</li> <li>• With start circuit energized, check for 48 volts DC across series relay coil.</li> <li>• With start circuit energized, check for 48 volts DC across starter relay coil.</li> <li>• With start circuit energized, check for proper voltage at the starter.</li> <li>• With start circuit energized, check for 28 volts DC across the relay coil.</li> <li>• Listen for sounds of starter rotation during an attempted start. If the starter rotates but the engine does not, the drive shaft is sheared.</li> </ul>	<ul style="list-style-type: none"> <li>• Adjust voltage of the external power source or charge batteries.</li> <li>• Replace switch.</li> <li>• Replace switch.</li> <li>• Place switch in OFF position.</li> <li>• Replace relay if no voltage is present.</li> <li>• Replace relay if no voltage is present.</li> <li>• Replace the starter if voltage is present.</li> <li>• Replace relay if voltage is not present.</li> <li>• Replace the engine.</li> </ul>
<b>Engine Starts But Does Not Accelerate To Idle</b>		
<ul style="list-style-type: none"> <li>• Insufficient starter voltage</li> </ul>	<ul style="list-style-type: none"> <li>• Check starter terminal voltage.</li> </ul>	<ul style="list-style-type: none"> <li>• Use larger capacity ground power unit or charge batteries</li> </ul>
<b>Engine Fails To Start When Throttle Is Placed In Idle</b>		
<ul style="list-style-type: none"> <li>• Defective ignition system</li> </ul>	<ul style="list-style-type: none"> <li>• Turn on system and listen for spark-igniter operation.</li> </ul>	<ul style="list-style-type: none"> <li>• Clean or replace spark igniters, or replace exciters or leads to igniters.</li> </ul>

Figure 13-6. Starter generator starting system troubleshooting procedures.

this overrun speed, the action of the sprag clutch allows the gear train to coast to a halt. The output shaft assembly and drive coupling continue to turn as long as the engine is running. A rotor switch actuator, mounted in the turbine rotor hub, is set to open the turbine switch when the starter reaches cutout speed. Opening the turbine switch interrupts an electrical signal to the start valve. This closes the valve and shuts off the air supply to the starter.

The turbine housing contains the rotor, the rotor switch actuator, and the nozzle components that direct the inlet air against the rotor blades. The turbine housing incorporates a rotor containment ring designed to dissipate the energy of blade fragments and direct their discharge at low energy through the exhaust duct in the event of rotor failure due to excessive turbine over speed. The transmission housing contains the reduction gears, the clutch components, and the drive coupling. The transmission housing also provides a reservoir for the lubricating oil. (Figure 13-9) Normal maintenance for air turbine starters includes checking the oil level, inspecting

the magnetic chip detector for metal particles, and checking for leaks. Oil can be added to the transmission housing sump through a port in the starter. This port is closed by a vent plug containing a ball valve that allows the sump to be vented to the atmosphere during normal flight. The housing also incorporates a sight plug in the transmission drain opening. A magnetic drain plug attracts any ferrous particles that may be in the oil. The starter uses turbine oil, the same as the engine, but this oil does not circulate through the engine.

The ring gear housing, which is internal, contains the rotor assembly. The switch housing contains the turbine switch and bracket assembly. To facilitate starter installation and removal, a mounting adapter is bolted to the mounting pad on the engine. Quick-detach clamps join the starter to the mounting adapter and inlet duct. (Figure 13-9) Thus, the starter is easily removed for maintenance or overhaul by disconnecting the electrical line, loosening the clamps, and carefully disengaging the drive coupling from the engine starter drive as the starter is withdrawn.

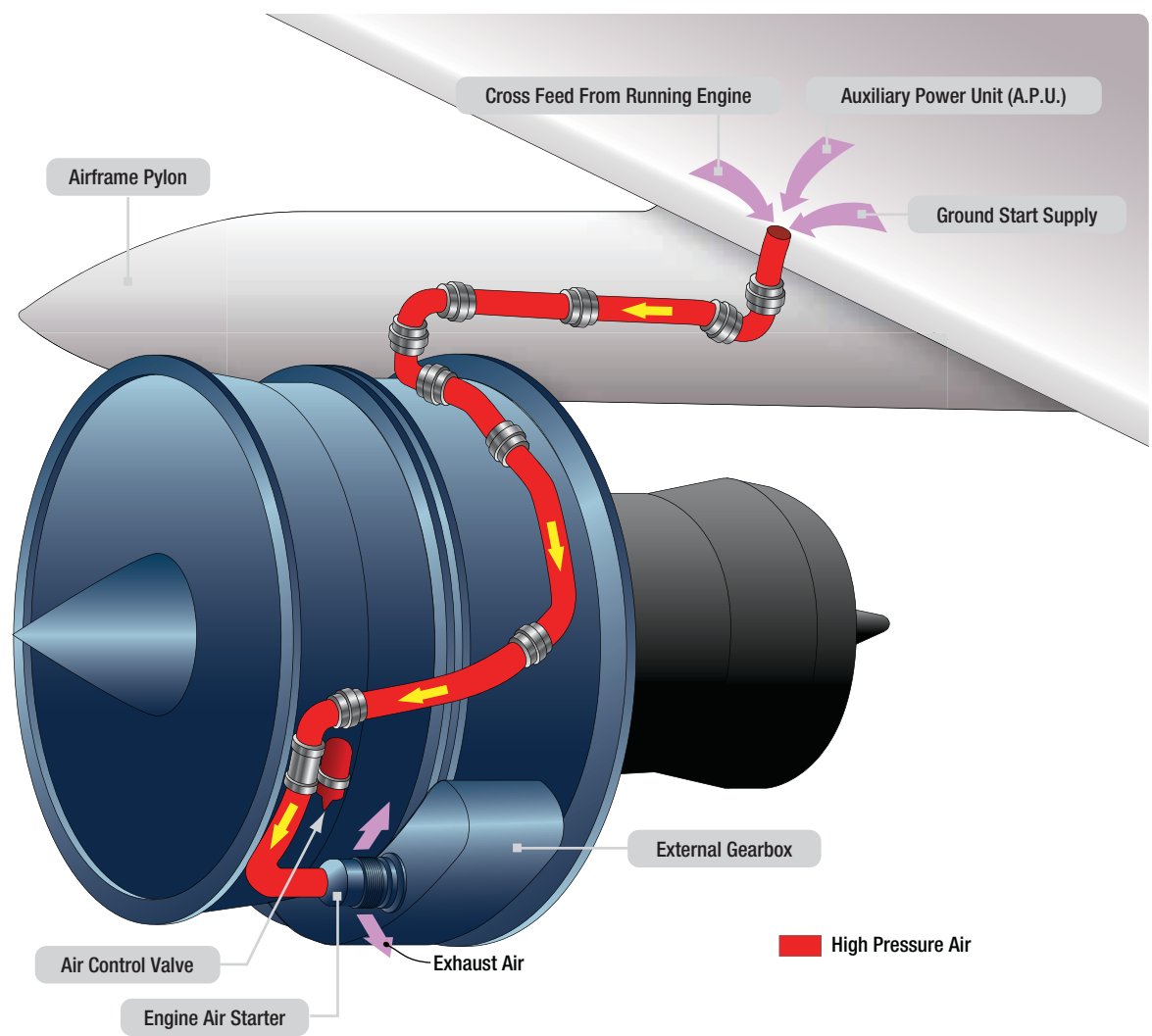

Figure 13-7. Air turbine starters are supplied by ground cart, APU, or another operating onboard engine.

The air path is directed through a combination pressure regulating and shutoff valves, or a bleed valve that controls all duct pressure flowing to the starter inlet ducting. This valve gauge is used to check the oil quantity. A magnetic drain regulates the pressure of the operating air and shuts off the air supply to the engine when selected off. Downstream from the bleed valve is the start valve, which is used to control air flow into the starter. (Figure 13-10)

The pressure-regulating and shutoff valve consists of two subassemblies: pressure-regulating valve and pressure regulating valve control. (Figure 13-11) The regulating valve assembly consists of a valve housing containing a butterfly type valve. (Figure 13-11)

The shaft of the butterfly valve is connected through a cam arrangement to a servo piston. When the piston is actuated, its motion on the cam causes rotation of the

butterfly valve. The slope of the cam track is designed to provide small initial travel and high initial torque when the starter is actuated. The cam track slope also provides more stable action by increasing the opening time of the valve.

The control assembly is mounted on the regulating valve housing and consists of a control housing in which a solenoid is used to stop the action of the control crank in the off position. The control crank links a pilot valve that meters pressure to the servo piston, with the bellows connected by an air line to the pressure-sensing port on the starter.

Turning on the starter switch energizes the regulating valve solenoid. The solenoid retracts and allows the control crank to rotate to the open position. The control crank is rotated by the control rod spring moving the control rod against the closed end of the bellows. Since

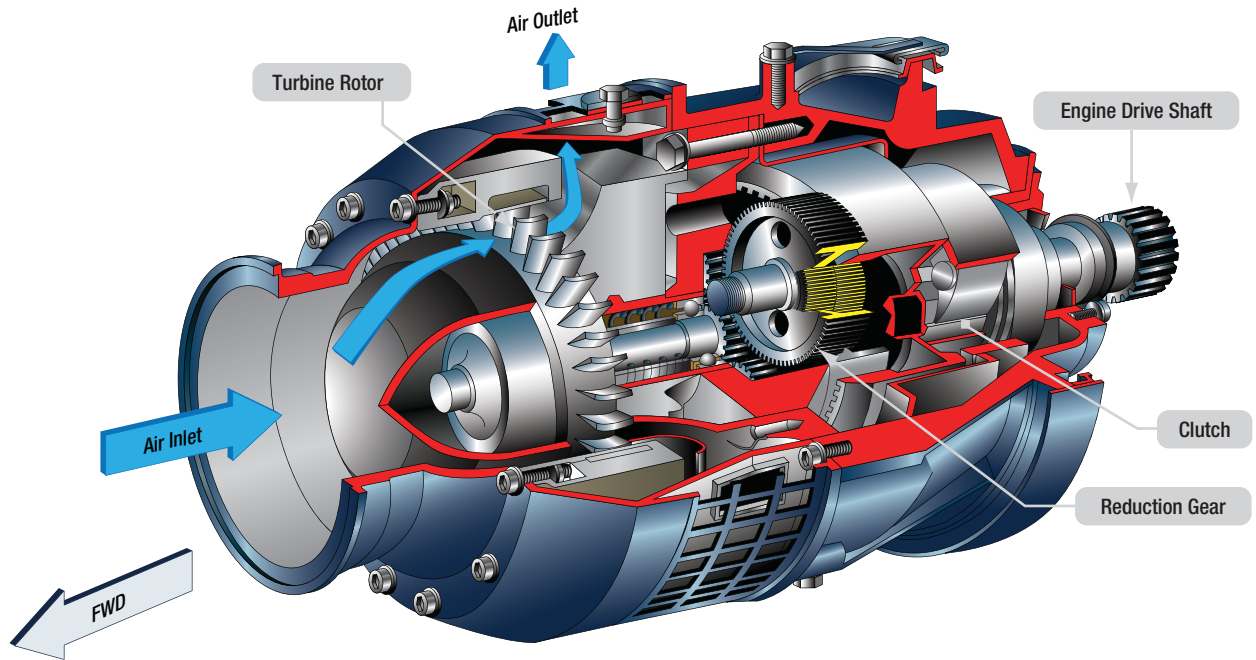

Figure 13-8. Cutaway view of an air turbine starter.

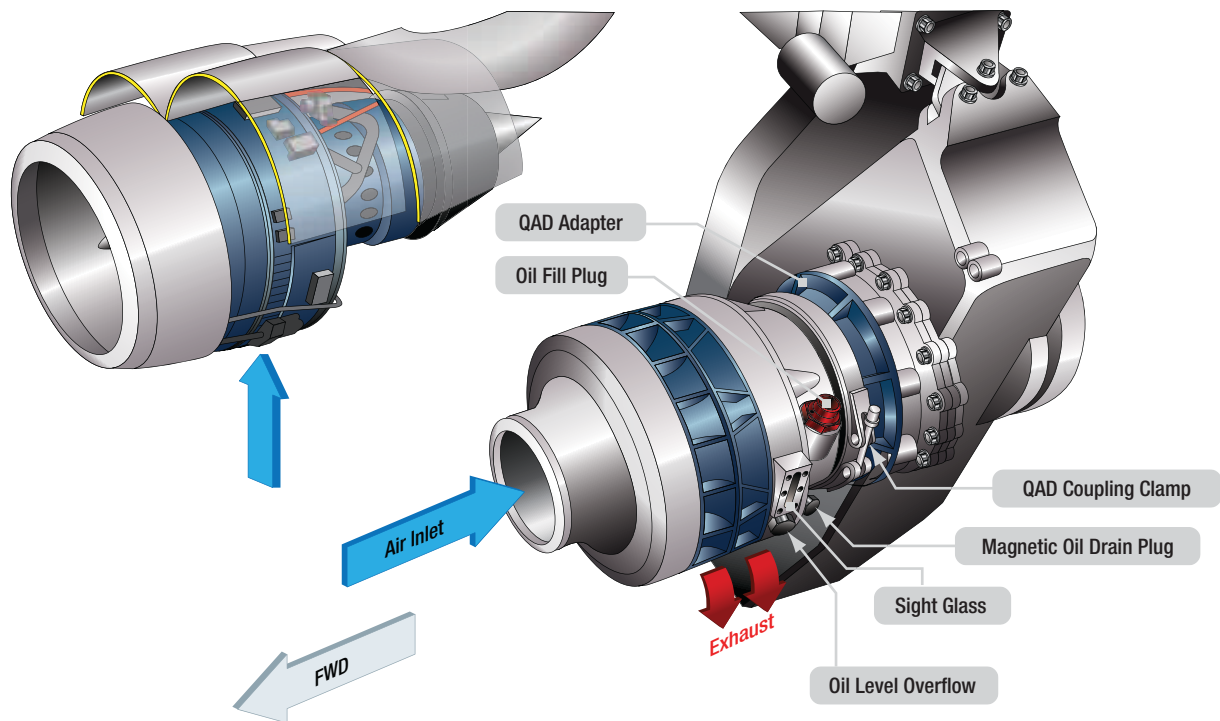

Figure 13-9. Air turbine starter.

the regulating valve is closed and downstream pressure is negligible, the bellows can be fully extended by the bellows spring.

As the control crank rotates to the open position, it causes the pilot valve rod to open the pilot valve, allowing upstream air, which is supplied through a suitable filter and a restriction in the housing, to flow into the servo

piston chamber. The drain side of the pilot valve, which bleeds the servo chamber to the atmosphere, is now closed by the pilot valve rod and the servo piston moves inboard. This linear motion of the servo piston is translated to rotary motion of the valve shaft by the rotating cam, thus opening the regulating valve. As the valve opens, downstream pressure increases. This pressure is bled back to the bellows through the



Figure 13-10. Start valve.

pressure-sensing line and compresses the bellows. This action moves the control rod, thereby turning the control crank, and moving the pilot valve rod gradually away from the servo chamber to vent to the atmosphere. When downstream (regulated) pressure reaches a preset value, the amount of air flowing into the servo through the restriction equals the amount of air being bled to the atmosphere through the servo bleed. The system is then in a state of equilibrium.

When the bleed valve and the start valve are open, the regulated air passing through the inlet housing of the starter impinges on the turbine causing it to turn. As the turbine turns, the gear train is activated and the inboard

clutch gear, which is threaded onto a helical screw, moves forward as it rotates; its jaw teeth engage those of the outboard clutch gear to drive the output shaft of the starter. The clutch is an overrunning type to facilitate positive engagement and minimize chatter. When starter cut-out speed is reached, the start valve is closed. When the air to the starter is terminated, the outboard clutch gear, driven by the engine, begins to turn faster than the inboard clutch gear; the inboard clutch gear, actuated by the return spring, disengages the outboard clutch gear allowing the rotor to coast to a halt. The outboard clutch shaft continues to turn with the engine.

**AIR TURBINE TROUBLESHOOTING GUIDE**

The troubleshooting procedures listed in *Figure 13-12* are applicable to air turbine starting systems equipped with a combination pressure-regulating and shutoff valve. These procedures should be used as a guide only, and are not intended to replace the manufacturer's instructions.

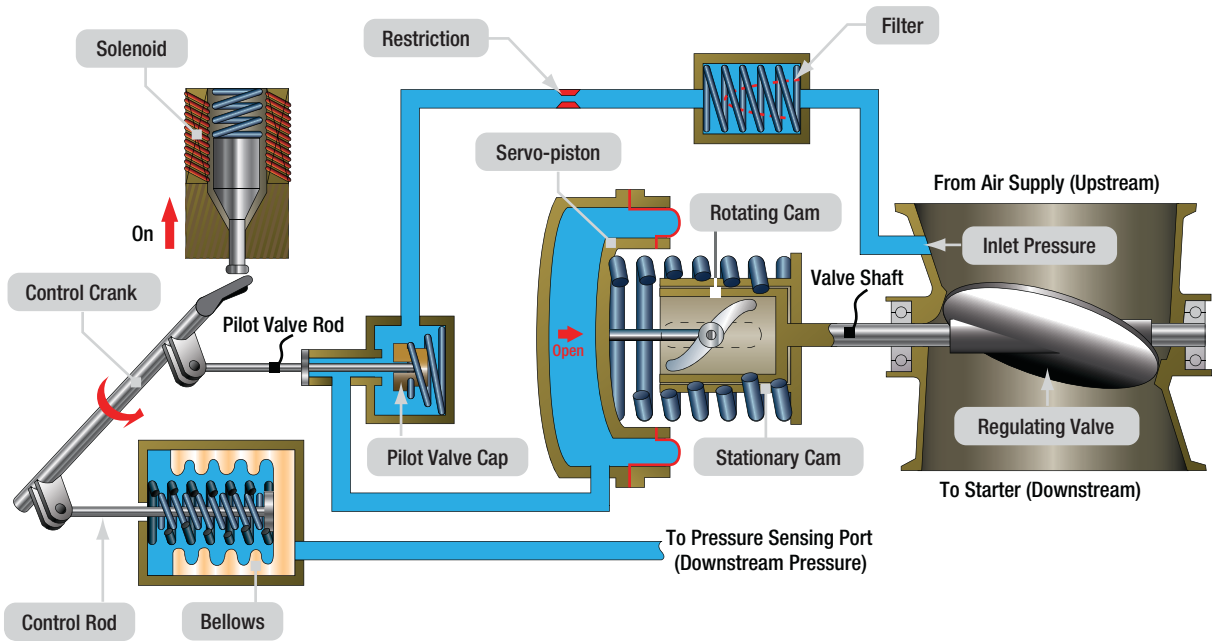

Figure 13-11. Pressure-regulating and shutoff valve in ON position.

Air Turbine Starter System Troubleshooting Procedures		
Trouble	Probable Cause	Remedy
<ul style="list-style-type: none"> <li>Starter does not operate (no rotation).</li> </ul>	<ul style="list-style-type: none"> <li>No air supply</li> <li>Electrical open in cutout switch</li> <li>Sheared starter drive coupling</li> <li>Internal starter discrepancy</li> </ul>	<ul style="list-style-type: none"> <li>Check air supply.</li> <li>Check switch continuity. If no continuity, remove starter and adjust or replace switch.</li> <li>Remove starter and replace drive coupling.</li> <li>Remove and replace starter.</li> </ul>
<ul style="list-style-type: none"> <li>Starter will not accelerate to normal cutoff speed.</li> </ul>	<ul style="list-style-type: none"> <li>Low starter air supply</li> <li>Starter cutout switch set improperly</li> <li>Valve pressure regulated too low</li> <li>Internal starter malfunction</li> </ul>	<ul style="list-style-type: none"> <li>Check air source pressure.</li> <li>Adjust rotor switch actuator.</li> <li>Replace valve.</li> <li>Remove and replace starter.</li> </ul>
<ul style="list-style-type: none"> <li>Starter will not cut off.</li> </ul>	<ul style="list-style-type: none"> <li>Low air supply</li> <li>Rotor switch actuator set too high</li> <li>Starter cutout switch shorted</li> </ul>	<ul style="list-style-type: none"> <li>Check air supply.</li> <li>Adjust switch actuator assembly.</li> <li>Replace switch and bracket assembly.</li> </ul>
<ul style="list-style-type: none"> <li>External oil leakage.</li> </ul>	<ul style="list-style-type: none"> <li>Oil level too high</li> <li>Loose vent, oil filler, or magnetic plugs</li> <li>Loose clamp band assembly</li> </ul>	<ul style="list-style-type: none"> <li>Drain oil and re-service properly.</li> <li>Tighten magnetic plug to proper torque.</li> <li>Tighten vent and oil filler plugs as necessary and lock wire. Tighten clamp band assembly to higher torque.</li> </ul>
<ul style="list-style-type: none"> <li>Starter runs, but engine does not turn over.</li> </ul>	<ul style="list-style-type: none"> <li>Sheared drive coupling</li> </ul>	<ul style="list-style-type: none"> <li>Remove starter and replace the drive coupling. If couplings persist in breaking in unusually short periods of time, remove and replace starter.</li> </ul>
<ul style="list-style-type: none"> <li>Starter inlet will not line up with supply ducting.</li> </ul>	<ul style="list-style-type: none"> <li>Improper installation of starter on engine, or improper indexing of turbine housing on starter</li> </ul>	<ul style="list-style-type: none"> <li>Check installation and/or indexing for conformance with manufacturer's installation instructions and the proper index position of the turbine housing specified for the aircraft.</li> </ul>
<ul style="list-style-type: none"> <li>Metallic particles on magnetic drain plug.</li> </ul>	<ul style="list-style-type: none"> <li>Small fuzzy particles indicate normal wear</li> <li>Particles coarser than fuzzy (chips, slivers, etc.) indicate internal difficulty</li> </ul>	<ul style="list-style-type: none"> <li>No remedial action required.</li> <li>Remove and replace starter.</li> </ul>
<ul style="list-style-type: none"> <li>Broken nozzle vanes.</li> </ul>	<ul style="list-style-type: none"> <li>Large foreign particles in air supply</li> </ul>	<ul style="list-style-type: none"> <li>Remove and replace starter and check air supply filter</li> </ul>
<ul style="list-style-type: none"> <li>Oil leakage from vent plug assembly.</li> </ul>	<ul style="list-style-type: none"> <li>Improper starter installation position</li> </ul>	<ul style="list-style-type: none"> <li>Check installed position for levelness of oil plugs and correct as required in accordance with manufacturer's installation instructions.</li> </ul>
<ul style="list-style-type: none"> <li>Oil leakage at drive coupling.</li> </ul>	<ul style="list-style-type: none"> <li>Leaking rear seal assembly</li> </ul>	<ul style="list-style-type: none"> <li>Remove and replace starter.</li> </ul>

Figure 13-12. Air turbine starter system troubleshooting procedures.

## TURBINE ENGINE IGNITION SYSTEMS

Since turbine ignition systems are operated mostly for a brief period during the engine-starting cycle, they are as a rule more trouble-free than the typical reciprocating engine ignition system. The turbine engine ignition system does not need to be timed to spark during an exact point in the operational cycle. It is used to ignite the fuel in the combustor and then it is switched off. Other modes of turbine ignition system operation, such as continuous ignition that is used at a lower voltage and energy level, are used for certain flight conditions.

Continuous ignition is used in case the engine were to flame out. This ignition could relight the fuel and keep

the engine from stopping. Examples of critical flight modes that use continuous ignition are takeoff, landing, and some abnormal and emergency situations.

Most gas turbine engines are equipped with a high-energy, capacitor-type ignition system and are air cooled by fan airflow. Fan air is ducted to the exciter box, and then flows around the igniter lead and surrounds the igniter before flowing back into the nacelle area. Cooling is important when continuous ignition is used for some extended period of time. Gas turbine engines may be equipped with an electronic-type ignition system, which is a variation of the simpler capacitor type system.

The typical turbine engine is equipped with a capacitor-type, or capacitor discharge, ignition system consisting of two identical independent ignition units operating from a common low-voltage (DC) electrical power source: the aircraft battery, 115AC, or its permanent magnet generator. The generator is turned directly by the engine through the accessory gear box and produces power any time the engine is turning. The fuel in turbine engines can be ignited readily in ideal atmospheric conditions, but since they often operate in the low temperatures of high altitudes, it is imperative that the system be capable of supplying a high heat intensity spark. Thus, a high-voltage is supplied to arc across a wide igniter spark gap, providing the ignition system with a high degree of reliability under widely varying conditions of altitude, atmospheric pressure, temperature, fuel vaporization, and input voltage.

A typical ignition system includes two exciter units, two transformers, two intermediate ignition leads, and two high tension leads. Thus, as a safety factor, the ignition system is actually a dual system designed to fire two igniter plugs. (*Figure 13-13*)

*Figure 13-14* is a functional schematic diagram of a typical capacitor-type turbine ignition system. A 24-volt DC input voltage is supplied to the input receptacle of the exciter unit. Before the electrical energy reaches the exciter unit, it passes through a filter that prevents noise voltage from being induced into the aircraft electrical system. The low-voltage input power operates a DC motor that drives one multilobe cam and one single-lobe cam. At the same time, input power is supplied to a set of breaker points that are actuated by the multilobe cam.

From the breaker points, a rapidly interrupted current is delivered to an auto transformer. When the breaker closes, the flow of current through the primary winding of the transformer establishes a magnetic field. When the breaker opens, the flow of current stops, and the collapse of the field induces a voltage in the secondary of the transformer. This voltage causes a pulse of current to flow into the storage capacitor through the rectifier, which limits the flow to a single direction. With repeated pulses, the storage capacitor assumes a charge, up to a maximum of approximately 4 joules. (Note: 1 joule per second equals 1 watt.) The storage capacitor is connected to the spark igniter through the triggering transformer and a contactor, normally open.

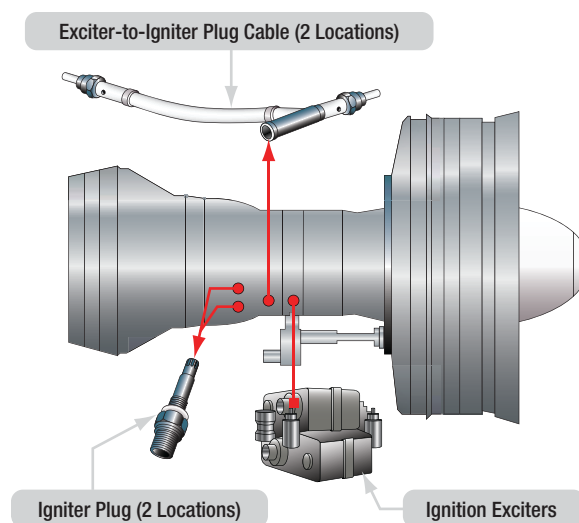

Figure 13-13. Turbine ignition system components.

When the charge on the capacitor has built up, the contactor is closed by the mechanical action of the single-lobe cam. A portion of the charge flows through the primary of the triggering transformer and the capacitor connected with it. This current induces a high-voltage in the secondary, which ionizes the gap at the spark igniter.

When the spark igniter is made conductive, the storage capacitor discharges the remainder of its accumulated energy along with the charge from the capacitor in series with the primary of the triggering transformer. The spark rate at the spark igniter varies in proportion to the voltage of the DC power supply that affects the rpm of the motor. However, since both cams are geared to the same shaft, the storage capacitor always accumulates its store of energy from the same number of pulses before discharge. The employment of the high-frequency triggering transformer, with a low reactance secondary winding, holds the time duration of the discharge to a minimum. This concentration of maximum energy in minimum time achieves an optimum spark for ignition purposes, capable of blasting carbon deposits and vaporizing globules of fuel.

All high-voltage in the triggering circuits is completely isolated from the primary circuits. The complete exciter is hermetically sealed, protecting all components from adverse operating conditions, eliminating the possibility of flashover at altitude due to pressure change. This also ensures shielding against leakage of high-frequency voltage interfering with the radio reception of the aircraft.

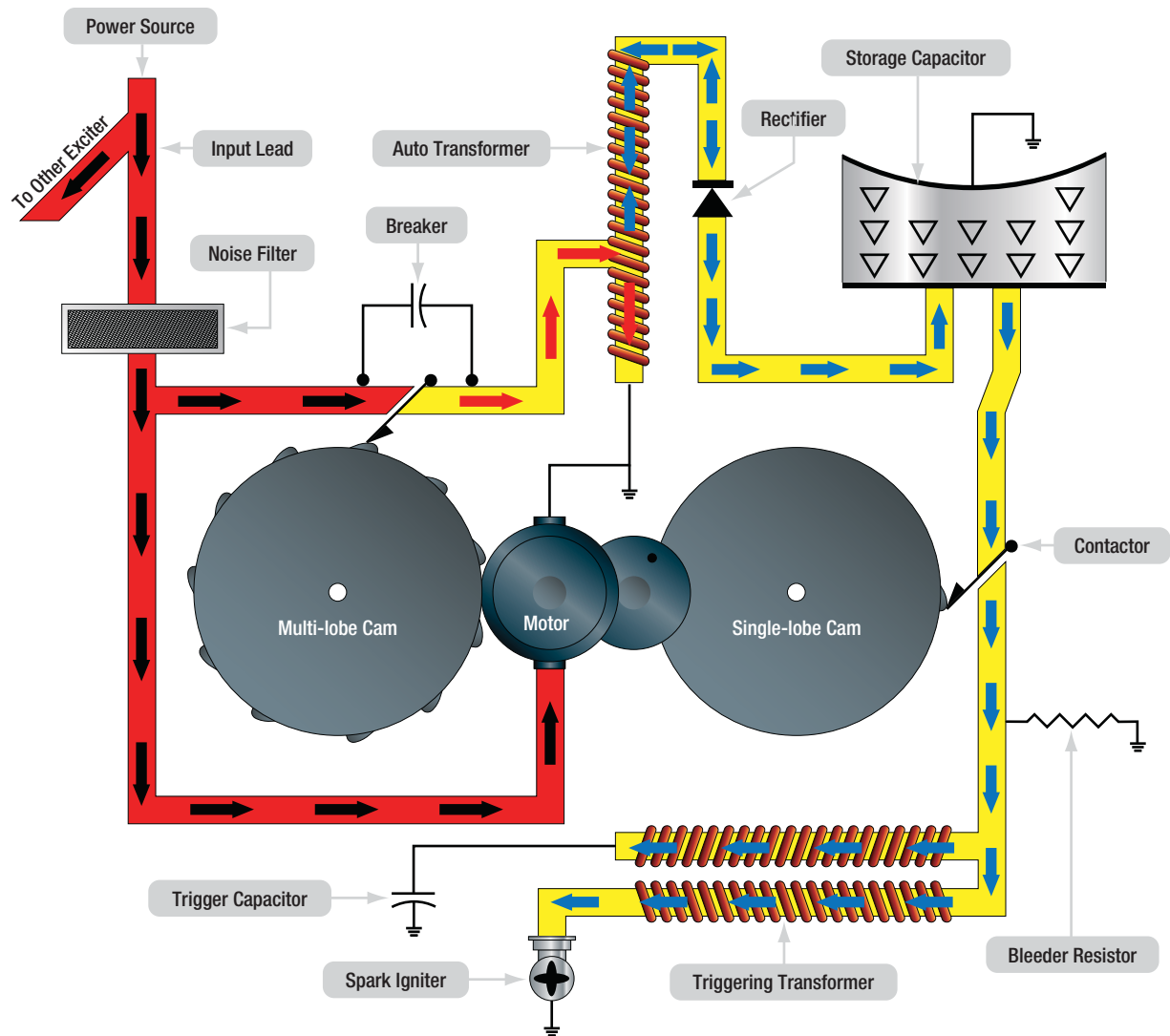

Figure 13-14. Capacitor-type ignition system schematic.

### IGNITION SYSTEM MAINTENANCE SAFETY

It is absolutely necessary to use caution and follow all manufacturer's instructions when working with turbine engine ignition systems. Residual high voltage and current in the ignition exciter can be present and injury or death may occur if it is released into the human body. The most likely way for an accidental discharge to occur is by touching the igniter. To perform igniter maintenance, standard procedure calls for disconnection of the igniter lead coupling nuts at the exciter end first. Insulated tools must be used and coupling nuts or connectors should not be touched with bare hands. Again, follow all manufacturer's procedures whenever working on a turbine engine ignition system.

### CAPACITOR DISCHARGE EXCITER UNIT

This capacitor-type system provides ignition for turbine engines. Like other turbine ignition systems, it is

required only for starting the engine; once combustion has begun, the flame is continuous. (Figure 13-15)

The energy is stored in capacitors. Each discharge circuit incorporates two storage capacitors; both are located in the exciter unit. The voltage across these capacitors is stepped up by transformer units. At the instant of igniter plug firing, the resistance of the gap is lowered sufficiently to permit the larger capacitor to discharge across the gap. The discharge of the second capacitor is of low-voltage, but of very high energy. The result is a spark of great heat intensity, capable of not only igniting abnormal fuel mixtures but also burning away any foreign deposits on the plug electrodes.

The exciter is a dual unit that produces sparks at each of the two igniter plugs. A continuous series of sparks is produced until the engine starts. The power is then

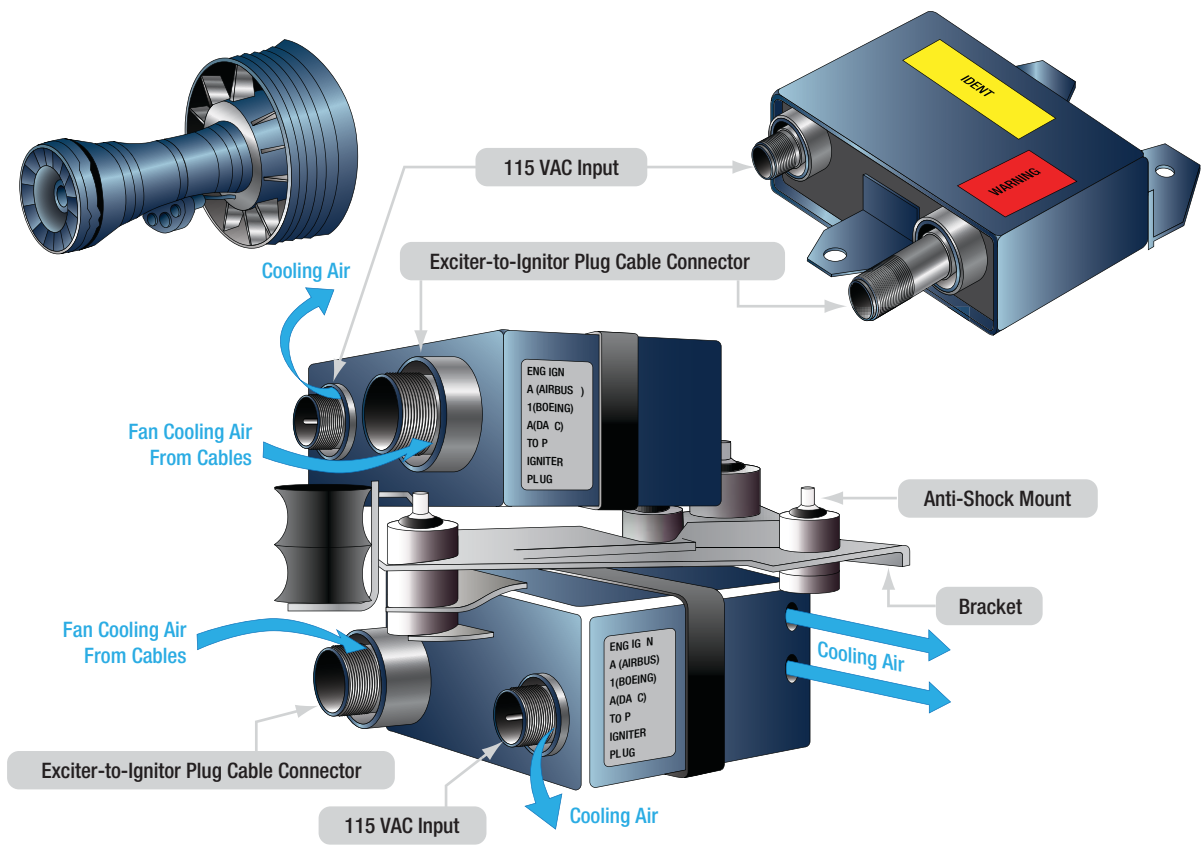

Figure 13-15. Fan air-cooled exciter.

cut off, and the plugs do not fire while the engine is operating other than on continuous ignition for certain flight conditions. This is why the exciters are air cooled to prevent overheating during long use of continuous ignition.

### IGNITER PLUGS

The igniter plug of a turbine engine ignition system differs considerably from the spark plug of a reciprocating engine ignition system. (Figure 13-16) Its electrode must be capable of withstanding a current of much higher energy than the electrode of a conventional spark plug. This high energy current can quickly cause electrode erosion, but the short periods of operation minimize this aspect of igniter maintenance. The electrode gap of the typical igniter plug is designed much larger than that of a spark plug since the operating pressures are much lower and the spark can arc more easily than in a spark plug. Finally, electrode fouling, common to the spark plug, is minimized by the heat of the high-intensity spark.

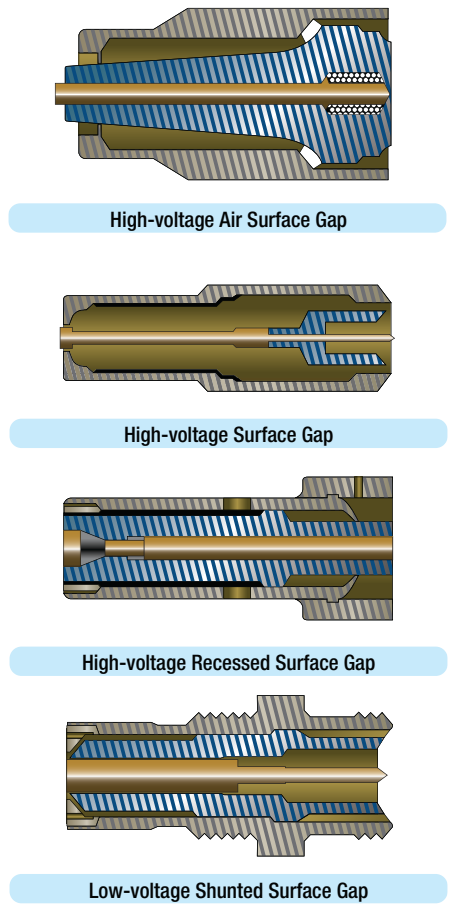

Figure 13-16. Igniter plugs.



*Figure 13-17* is a cutaway illustration of a typical annular-gap igniter plug, sometimes referred to as a long reach igniter because it projects slightly into the combustion chamber liner to produce a more effective spark.

Another type of igniter plug, the constrained-gap plug, is used in some types of turbine engines. (*Figure 13-18*) It operates at a much cooler temperature because it does not project into the combustion-chamber liner. This is possible because the spark does not remain close to the plug, but arcs beyond the face of the combustion chamber liner.

### TURBINE IGNITION SYSTEM INSPECTION AND MAINTENANCE

Maintenance of the typical turbine engine ignition system consists primarily of inspection, test, troubleshooting, removal, and installation.

### INSPECTION

Inspection of the ignition system normally includes the following:

- Ignition lead terminal inspection; ceramic terminal should be free of arcing, carbon tracking and cracks.
- The grommet seal should be free of flashover and carbon tracking. (*Figure 13-19*)
- The wire insulation should remain flexible with no evidence of arcing through the insulation.
- Inspect the complete system for security of component mounting, shorts or high-voltage arcing, and loose connections.

### CHECK SYSTEM OPERATION

The igniter can be checked by listening for a snapping noise as the engine begins to turn, driven by the starter. The igniter can also be checked by removing it and activating the start cycle, noting the spark across the igniter. CAUTION: The high energy level and voltage associated with turbine ignition systems can cause

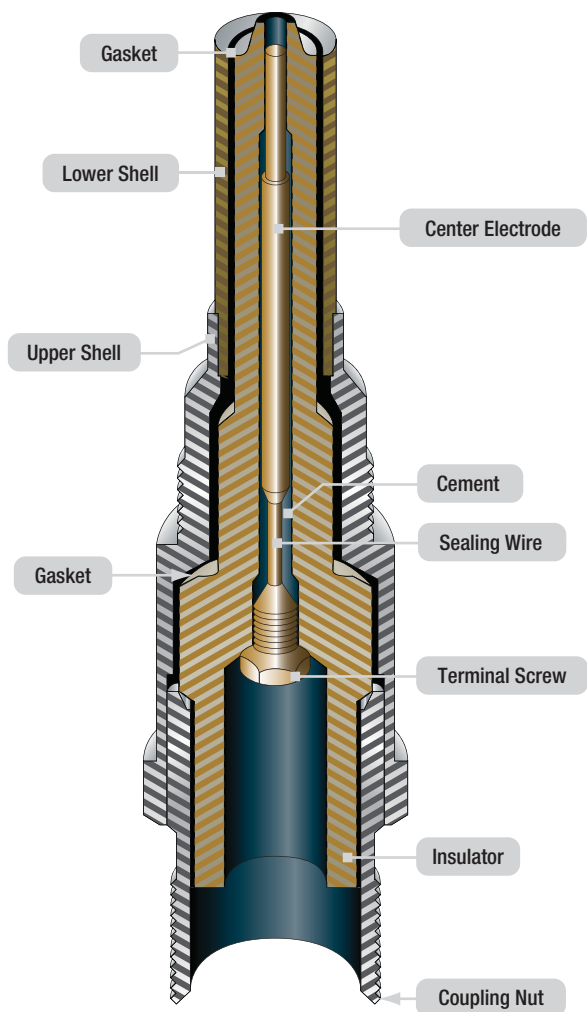

Figure 13-17. Typical annular gap igniter plug.

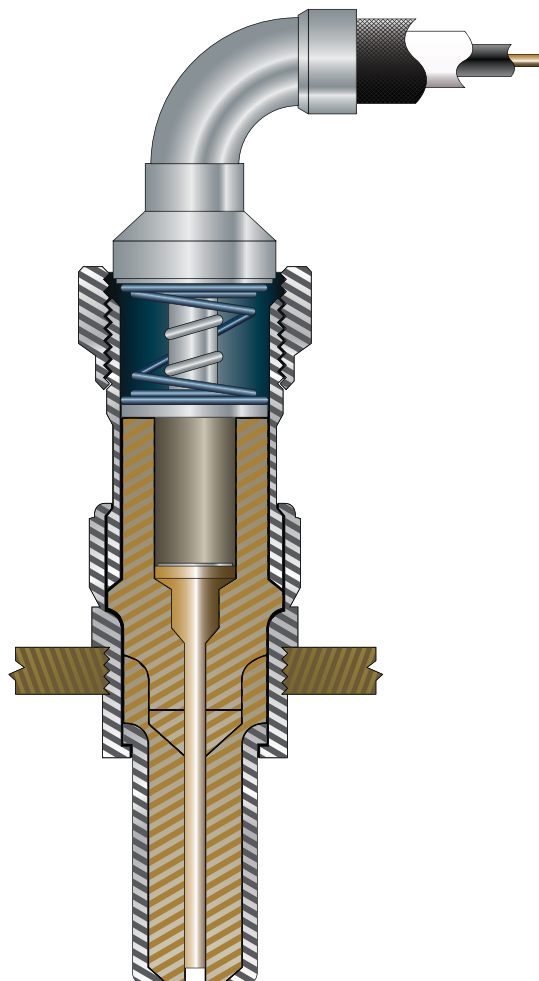

Figure 13-18. Constrained gap igniter plug.

injury or death to personnel coming into contact with the activated system.

## REPAIR

Tighten and secure as required and replace faulty components and wiring. Secure, tighten, and safety as required.

## REMOVAL, MAINTENANCE AND INSTALLATION OF IGNITION SYSTEM COMPONENTS

The following instructions are typical procedures suggested by many gas turbine manufacturers. These instructions are applicable to the engine ignition components. Always consult the applicable manufacturer's instructions before performing any ignition system maintenance.

### IGNITION SYSTEM LEADS

1. Remove clamps securing ignition leads to engine.
2. Remove safety wire and disconnect electrical connectors from exciter units.
3. Remove safety wire and disconnect lead from igniter plug.
4. Discharge any electrical charge stored in the system by grounding and remove ignition leads from engine.
5. Clean leads with approved dry cleaning solvent.
6. Inspect connectors for damaged threads, corrosion, cracked insulators, and bent or broken connector pins.
7. Inspect leads for worn or burned areas, deep cuts, fraying, and general deterioration.
8. Perform continuity check of ignition leads.
9. Reinstall leads, reversing the removal procedure.

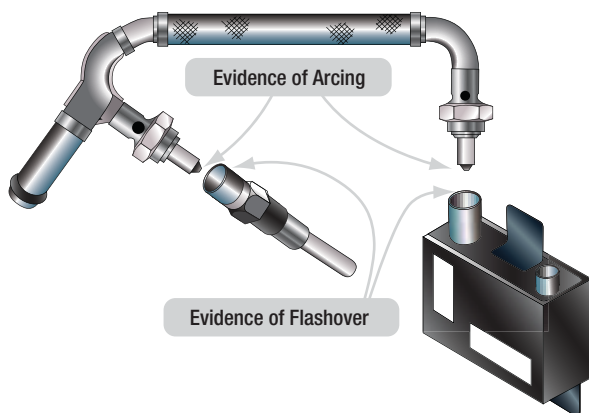

Figure 13-19. Flashover inspection.

## IGNITER PLUGS

1. Disconnect ignition leads from igniter plugs. A good procedure to perform before disconnecting the ignition lead is to disconnect the low-voltage primary lead from the ignition exciter unit and wait at least one minute to permit the stored energy to dissipate before disconnecting the high-voltage cable from the igniter.
2. Remove igniter plugs from mounts.
3. Inspect igniter plug gap surface material. Before inspection, remove residue from the shell exterior using a dry cloth. Do not remove any deposits or residue from the firing end of the low-voltage igniters. High-voltage igniters can have the firing end cleaned to aid in inspection. (Figure 13-20)
4. Inspect for fretting of igniter plug shank.
5. Replace an igniter plug whose surface is granular, chipped, or otherwise damaged.
6. Replace dirty or carbonized igniter plugs.
7. Install igniter plugs in mounting pads.
8. Check for proper clearance between chamber liner and igniter plug.
9. Tighten igniter plugs to manufacturer's specified torque.
10. Safety wire igniter plugs.

Gap Description	Typical Firing End Configuration	Clean Firing End
High-voltage Air Surface Gap		Yes
High-voltage Surface Gap		Yes
High-voltage Recessed Surface Gap		Yes
Low-voltage Shunted Surface Gap		No

Figure 13-20. Firing end cleaning.



**Question:** 13-1

On a turbine engine, once ignition and fuel has been introduced and light-off has occurred, the starter must continue to assist the engine until the engine reaches \_\_\_\_\_ speed.

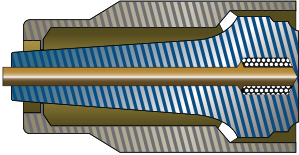
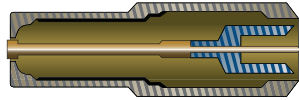
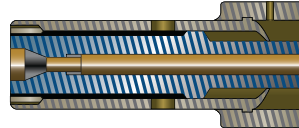
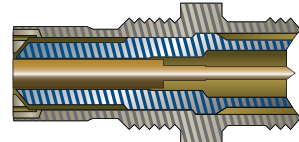
**Question:** 13-5

Most gas turbine engines are equipped with a high energy, \_\_\_\_\_ ignition system and are air cooled by fan airflow.

**Question:** 13-2

\_\_\_\_\_ starting systems are used mostly on small turbine engines, such as Auxiliary Power Units (APUs), and some small turboshaft engines.

**Question:** 13-6

The igniter plug of a turbine engine ignition system carries \_\_\_\_\_ current than a spark plug of a reciprocating engine ignition system.

**Question:** 13-3

The typical air turbine starter consists of an axial flow turbine that turns a drive coupling through a \_\_\_\_\_ and a starter clutch mechanism.

**Question:** 13-7

The turbine engine igniter can be checked by listening for \_\_\_\_\_ as the engine begins to turn, driven by the starter.

**Question:** 13-4

Bleed air is delivered to the air starter turbine rotor through the \_\_\_\_\_.

**Question:** 13-7

For safety purposes when inspecting ignitor plugs, what should be done before disconnecting the ignition lead from the plug?

## ANSWERS

*Answer:* 13-1  
self sustaining.

*Answer:* 13-5  
capacitor-type.

*Answer:* 13-2  
Direct cranking electric.

*Answer:* 13-6  
more.

*Answer:* 13-3  
reduction gear train.

*Answer:* 13-7  
a snapping noise.

*Answer:* 13-4  
start valve.

*Answer:* 13-8  
Disconnect the low voltage lead from the exciter unit.



PART-66 SYLLABUS LEVELS  
 CERTIFICATION CATEGORY → A1 B1

**Sub-Module 14**  
**ENGINE INDICATION SYSTEMS**  
 Knowledge Requirements

*15.14 - Engine Indication Systems*

- Exhaust Gas Temperature/Interstage Turbine Temperature;
- Engine Thrust Indication: Engine Pressure Ratio, engine turbine discharge pressure or jet pipe pressure systems;
- Oil pressure and temperature;
- Fuel pressure and flow;
- Engine speed;
- Vibration measurement and indication;
- Torque;
- Power.

CERTIFICATION CATEGORY →	A1	B1
	1	2

ENGINE INDICATION SYSTEMS

**Level 1**  
 A familiarization with the principal elements of the subject.

*Objectives:*

- (a) The applicant should be familiar with the basic elements of the subject.
- (b) The applicant should be able to give a simple description of the whole subject, using common words and examples.
- (c) The applicant should be able to use typical terms.

**Level 2**  
 A general knowledge of the theoretical and practical aspects of the subject and an ability to apply that knowledge.

*Objectives:*

- (a) The applicant should be able to understand the theoretical fundamentals of the subject.
- (b) The applicant should be able to give a general description of the subject using, as appropriate, typical examples.
- (c) The applicant should be able to use mathematical formula in conjunction with physical laws describing the subject.
- (d) The applicant should be able to read and understand sketches, drawings and schematics describing the subject.
- (e) The applicant should be able to apply his knowledge in a practical manner using detailed procedures.

# ENGINE INDICATING SYSTEMS

## EXHAUST GAS TEMPERATURE INDICATOR (EGT)

Exhaust gas temperature (EGT), turbine inlet temperature, (TIT), turbine gas temperature (TGT), interstage turbine temperature (ITT), and turbine outlet temperature (TOT) are all relative temperatures used to monitor the temperature of the exhaust gases entering the first stage turbine inlet guide vanes. Even though these temperatures are taken at different locations on the engine (each engine having one location), they are all relative to the temperature of the gases entering the first stage turbine inlet guide vanes.

Temperature is an engine operating limit and is used to monitor the mechanical integrity of the turbines, as well as to check engine operating conditions. Actually, the temperature of the gases entering the first stage turbine inlet guide vanes is the important consideration, since it is the most critical of all the engine variables. However, it is impractical to measure turbine inlet temperature in most engines, especially large engines. Consequently, temperature thermocouples are inserted at the turbine discharge, where the temperature provides a relative indication of that at the inlet. Although the temperature at this point is much lower than at the inlet, it provides surveillance over the engine's internal operating conditions. Several thermocouples are usually used, that are spaced at intervals around the perimeter of the engine exhaust duct near the turbine exit. The EGT indicator in the flight deck shows the average temperature measured by the individual thermocouples. (Figure 14-1)



Figure 14-1. A typical analog exhaust gas temperature gauge

Several thermocouples are used to measure EGT, TIT, or any of the other temperature parameters mentioned. They are spaced at intervals around the perimeter of the engine turbine casing or exhaust duct. The tiny thermocouple voltages are typically amplified and used to energize a servomotor that drives the indicator pointer. (Figure 14-2) Gearing a digital drum indication off of the pointer motion is common.

The EGT indicator shown is a hermetically sealed unit. The instrument's scale ranges from 0 °C to 1 200 °C, with a vernier dial in the upper right-hand corner and a power off warning flag located in the lower portion of the dial.

A TIT indicating system provides a visual indication at the instrument panel of the temperature of gases entering the turbine. Numerous thermocouples can be

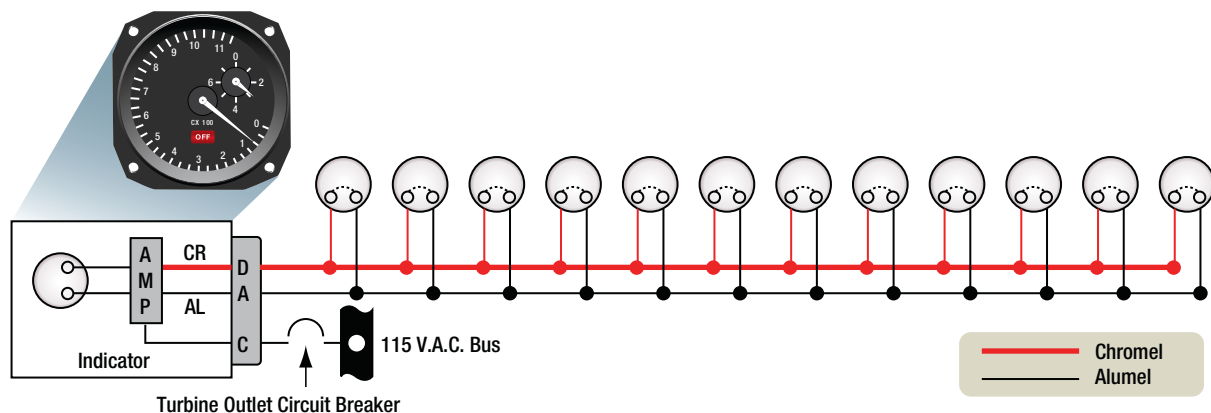

Figure 14-2. A typical exhaust gas temperature thermocouple system.

used with the average voltage representing the TIT. Dual thermocouples exist containing two electrically independent junctions within a single probe. One set of these thermocouples is paralleled to transmit signals to the cockpit indicator. The other set of parallel thermocouples provides temperature signals to engine monitoring and control systems. Each circuit is electrically independent, providing dual system reliability.

A schematic for the turbine inlet temperature system for one engine of a four-engine turbine aircraft is shown in *Figure 14-3*. Circuits for the other three engines are identical to this system. The indicator contains a bridge circuit, a chopper circuit, a two-phase motor to drive the pointer, and a feedback potentiometer. Also included are a voltage reference circuit, an amplifier, a power-off flag, a power supply, and an over temperature warning light. Output of the amplifier energizes the variable field of the two-phase motor that positions the indicator main pointer and a digital indicator. The

motor also drives the feedback potentiometer to provide a humming signal to stop the drive motor when the correct pointer position, relative to the temperature signal, has been reached. The voltage reference circuit provides a closely regulated reference voltage in the bridge circuit to preclude error from input voltage variation to the indicator power supply.

An over-temperature warning light in the indicator illuminates when the TIT reaches a predetermined limit. An external test switch is usually installed so that over temperature warning lights for all the engines can be tested at the same time. When the test switch is operated, an over-temperature signal is simulated in each indicator temperature control bridge circuit.

Digital cockpit instrumentation systems need not employ resistance-type indicators and adjusted servo-driven thermocouple gauges to provide the pilot with temperature information. Sensor resistance and voltage

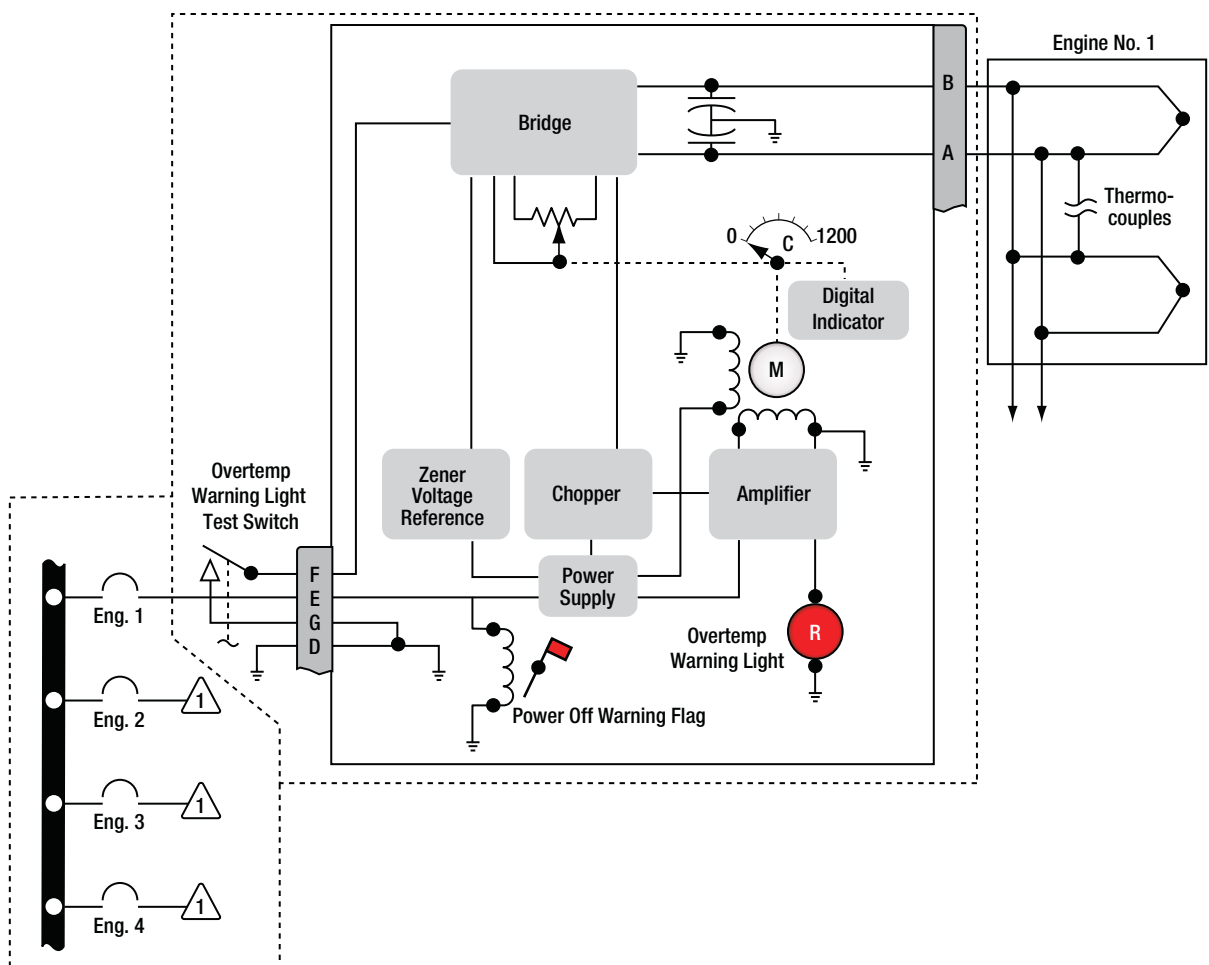
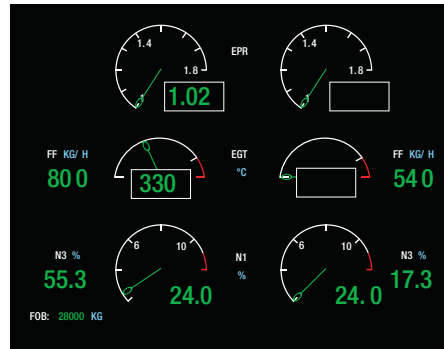

Figure 14-3. A typical analog turbine inlet temperature indicating system.





A. An analog EPR gauge from a turbine engine.



B. A digital EPR indication and other turbine engine parameters on a cockpit digital display screen.

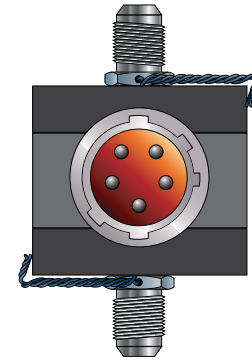

C. Engine pressure ratio transducer.

Figure 14-4. Typical EPR indications and a ratio transducer.

values are input to the appropriate computer, where they are adjusted, processed, monitored, and output for display on cockpit display panels. They are also sent for use by other computers requiring temperature information for the control and monitoring of various integrated systems.

## ENGINE PRESSURE RATIO (EPR) INDICATOR

Turbine engines have a pressure indicator that relates the power being developed by the engine. It is called the engine pressure ratio (EPR) indicator or EPR gauge. This gauge compares the engine turbine discharge pressure to the pressure of the ram air at the inlet of the engine and is considered a measure of the thrust being developed. With adjustments for temperature, altitude, and other factors, the EPR gauge presents an indication of the thrust being developed by the engine. Since the EPR gauge compares two pressures, it is a differential pressure gauge. It is a remote-sensing instrument that receives its input from an engine pressure ratio transmitter or, in digital instrument systems displays, from a computer. The pressure ratio transmitter contains the bellows arrangement that compares the two pressures and converts the ratio into an electric signal used by the gauge for indication. (Figure 14-4) EPR is used to set power for takeoff on many types of aircraft. It is instrumented by total pressure pickups in the engine inlet (Pt2) and in the turbine exhaust (Pt7).

## TORQUEMETER (TURBOPROP ENGINES)

Less than 15 percent of the thrust produced by a turboprop engine is from propulsive force derived from the jet thrust exiting the exhaust. Engine pressure ratio

is not used as an indicator of the power produced by a turboprop engine. Turboprops are usually fitted with a torque meter that measures torque applied to a shaft turned by the gas generator and power turbines of the turbine engine. The torque meter can be operated by engine oil pressure metered through a valve that is controlled by a helical ring gear that moves in response to the applied torque. (Figure 14-5)

This gear moves against a piston that controls the opening of a valve, which controls the oil pressure flow. This action makes the oil pressure proportional to torque being applied at the propeller shaft. Generally, transducer is used to transfer the oil pressure into an electrical signal to be read by the flight deck instrument. The read out in the flight deck is normally in lb/ft of torque, or percent horsepower. The torque meter is very important as it is used to set power settings. This instrument must be calibrated at intervals to assure its accuracy.



Figure 14-5. A typical analog torque meter.

## TACHOMETER

Gas turbine engine speeds are measured by engine rpm. The rpm of each rotating spool (compressor section/turbine combination) is measured. Most turbofan engines have two or more spools that turn independently at different speeds. Tachometers are usually calibrated in percent rpm so that various types of engines can be operated on the same basis of comparison. (*Figure 14-6*) Also, turbine speeds are generally very high and the large numbers of rpm would make it confusing especially when operating different aircraft. Turbofan engines with two spools or separate shafts, high pressure and low pressure spools, are generally referred to as N1 and N2, with each having their own indicator. The main purpose of the tachometer is to be able to monitor rpm under normal conditions, during an engine start, and to indicate an overspeed condition, if one occurs.

Turbine engine tachometers are typically electric or probe-type. Manufacturer's instructions should be

consulted for details of each specific tachometer system. A popular electric tachometer system makes use of a small AC generator mounted to a reciprocating engine's gear case or the accessory drive section of a turbine engine. As the engine turns, so does the generator. The frequency output of the generator is directly proportional to the speed of the engine. It is connected via wires to a synchronous motor in the indicator that mirrors this output. A drag cup, or drag disk link, is used to drive the indicator as in a mechanical tachometer. (*Figure 14-7*) Two different types of generator units, distinguished by their type of mounting system, are shown in *Figure 14-8*.

Turbine engines tachometer probes for rpm indication provide a great advantage in that there are no moving parts in the system. They are sealed units that are mounted on a flange and protrude into the compressor section of the engine. A magnetic field is set up inside the probe that extends through pole pieces and out the end of the probe. A rotating gear wheel, which moves at the same speed as the engine compressor shaft, alters the magnetic field flux density as it moves past the pole pieces at close proximity. This generates voltage signals in coils inside the probe. The amplitude of the EMF signals vary directly with the speed of the engine. (*Figure 14-9*)



Figure 14-6. A typical analog RPM gauge.

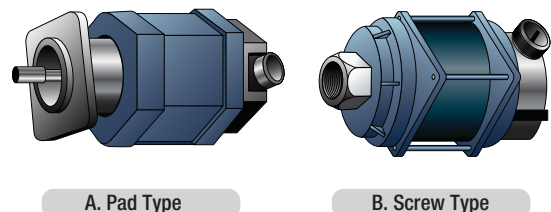

Figure 14-8. Different types of tach generators.

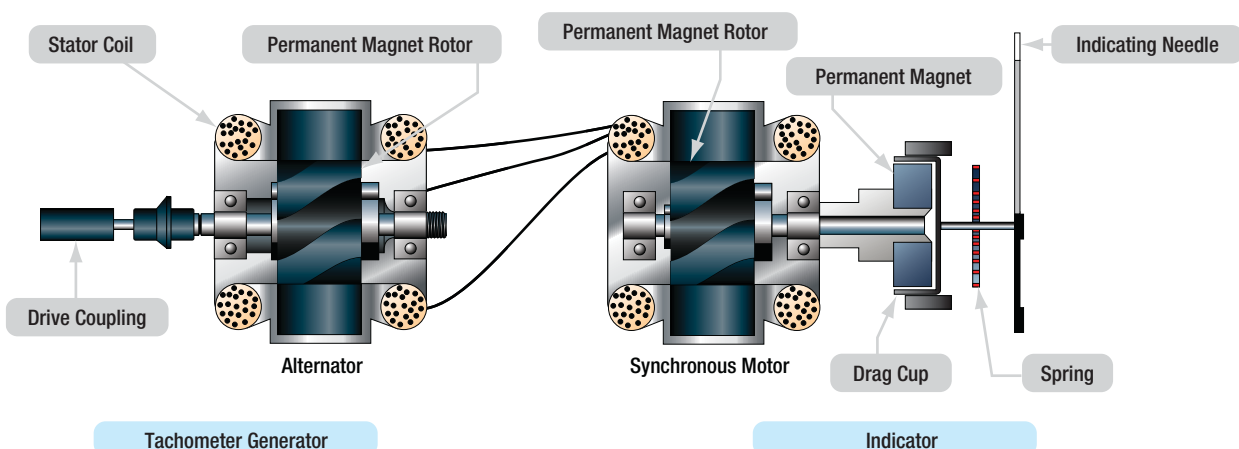

Figure 14-7. An electric tachometer system with synchronous motors and a drag cup indicator.

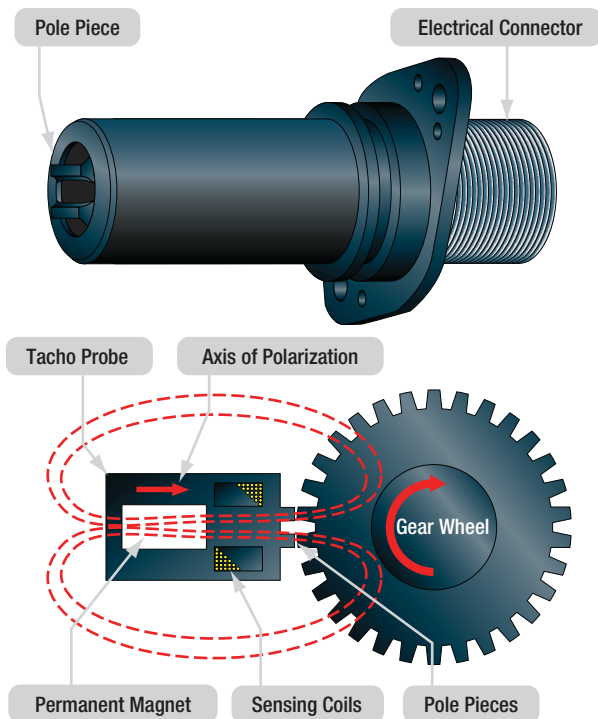

Figure 14-9. A tacho probe has no moving parts. The rate of magnetic flux field density change is directly related to the engine speed.

The tachometer probe's output signals need to be processed in a remotely located module. They may be amplified to drive a servo motor type indicator in the cockpit or conditioned for digital display. They may also be used as input for an automatic power control system or a flight data acquisition system.

## FUEL-FLOW INDICATOR

Fuel-flow instruments indicate the fuel flow in pounds per hour (lbs/hr) from the engine fuel control. Fuel flow in turbine aircraft is measured in lbs/hr instead of gallons, because the fuel weight is a major factor in the aerodynamics of large turbine aircraft. Fuel flow is of interest in monitoring fuel consumption and checking engine performance. (Figure 14-10)

In most turbine aircraft installations, the fuel flow indicating system consists of a transmitter and an indicator for each engine. The fuel flow transmitter is conveniently mounted in the engine's accessory section and measures the fuel flow between the engine-driven fuel pump and the fuel control device. The transmitter is an electrical device that contains a turbine that turns faster as the flow increases, which increases the electrical signal to the indicator. The fuel flow transmitter is connected electrically to the indicator located on the aircraft flight deck, or on the test cell operator's panel.

## ENGINE OIL PRESSURE INDICATOR

To guard against engine failure resulting from inadequate lubrication and cooling of the various engine parts, the oil supply to critical areas must be monitored. The oil pressure indicator usually shows the engine oil pump discharge pressure. (Figure 14-11)

## ENGINE OIL TEMPERATURE INDICATOR

The ability of the engine oil to lubricate and cool depends on the temperature of the oil, as well as the amount of oil supplied to the critical areas. An oil inlet temperature indicator frequently is provided to show the temperature of the oil as it enters the oil pressure pump. Oil inlet temperature is also an indication of proper operation of the engine oil cooler. (Figure 14-12)

## VIBRATION MONITORING

An engine vibration indication on a tubing engine aircraft is a secondary engine instrument parameter that indicates the amount of vibration measured on the engine low pressure rotor and/or the high pressure rotor. Vibration is displayed in non-dimensional units, and is used for condition monitoring, identification of the affected engine after foreign object ingestion, and detection of fan unbalance due to icing. The level of vibration will change with engine speed. Vibration monitors in general track rotor imbalance.

Modern engines equipped with vibration monitoring systems use piezo-electric sensors. A mass inside the sensor housing impinges on the piezo causing a current flow in proportion to the vibration. This can be amplified and displayed via an analog ammeter type gauge or digitalized for indication on an EICAS or ECAM display.



Figure 14-10. A typical analog fuel flow gauge.



Figure 14-11. A typical analog oil pressure gauge.

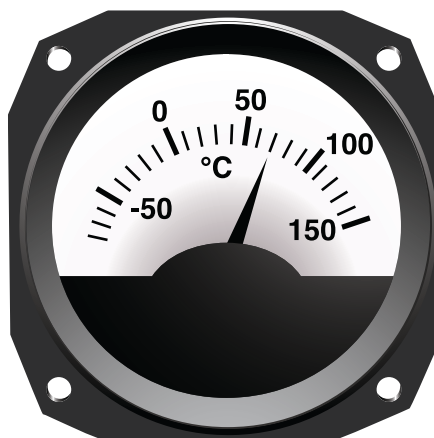

Figure 14-12. A typical analog oil temperature gauge.



**Question:** 14-1

EGT, TIT, TGT, ITT and TOT are all relative temperatures used to monitor the temperature of the exhaust gases entering \_\_\_\_\_.

**Question:** 14-5

Fuel flow is of interest in monitoring fuel \_\_\_\_\_ and checking engine performance.

**Question:** 14-2

Which turbine engine gauge is used to indicate the thrust developed?

**Question:** 14-6

Vibration monitors on turbine engines generally track \_\_\_\_\_ imbalance.

**Question:** 14-3

What does the RPM measurement indicate in a turbine engine?

**Question:** 14-7

What does N1 and N2 refer to in relation to engine rpm?

**Question:** 14-4

Turbine engines tachometer probes for rpm indication provide a great advantage in that there are \_\_\_\_\_ in the system.

**Question:** 14-8

What type of engine uses a torquemeter and what is actually measured?

## ANSWERS

*Answer:* 14-1

the first stage turbine inlet guide vanes.

*Answer:* 14-5

consumption.

*Answer:* 14-2

EPR (engine pressure ratio) gauge.

*Answer:* 14-6

rotor.

*Answer:* 14-3

The rotational speed of the spool.

*Answer:* 14-7

The rotational speeds of the low and high pressure compressor spools.

*Answer:* 14-4

no moving parts.

*Answer:* 14-8

Turboprop engines; oil pressure at a helical ring gear.



PART-66 SYLLABUS LEVELS  
 CERTIFICATION CATEGORY → A1 B1

**Sub-Module 15**  
**POWER AUGMENTATION SYSTEMS**

Knowledge Requirements

*15.15 - Power Augmentation Systems*

- Operation and applications;
- Water injection, water methanol;
- Afterburner systems.

CERTIFICATION CATEGORY →	A1	B1
	-	1

POWER AUGMENTATION SYSTEMS

**Level 1**  
 A familiarization with the principal elements of the subject.

*Objectives:*

- (a) The applicant should be familiar with the basic elements of the subject.
- (b) The applicant should be able to give a simple description of the whole subject, using common words and examples.
- (c) The applicant should be able to use typical terms.



## POWER AUGMENTATION SYSTEMS

### AFTER BURNING/THRUST AUGMENTATION

Some low-bypass turbofan engines are used in speed ranges above .8 Mach (military aircraft). These engines use augmenters or afterburners to increase thrust. By adding more fuel nozzles and a flame holder in the exhaust system extra fuel can be sprayed and burned which can give large increases in thrust for short amounts of time.

The terms after burning and thrust augmentation generally pertain to military engine applications. The terms are used to describe the same system. Normally, this is used to increase the thrust of the engine up to double the original thrust. The required additions to the exhaust nozzle for this system are a flame stabilizer, fuel manifold, flame holder, igniter, and a variable area exhaust nozzle. (*Figure 15-1*)

After the engine has reached full power under normal operation, the power lever can be advanced to activate the afterburner. This allows more fuel to flow into the

exhaust nozzle where it is ignited and burned. As energy and mass is added to the gas flow, the exhaust nozzle must open wider to allow greater flow. As the power lever is moved back out of the afterburner, the exhaust nozzle closes down again. Some low-bypass turbofan engines used in military aircraft use bypass (fan air) to flow into the exhaust nozzle. Just as in a ducted fan, this air is used in the afterburner. It contains more oxygen and assists combustion in the afterburner.

Since fuel is being burned in the exhaust nozzle, the heat buildup around the nozzle is a problem. A special type of liner is used around the nozzle to allow cooler air to circulate around the nozzle. This operates somewhat like a single burner can combustion chamber. Operation in the afterburner mode is somewhat limited by high fuel consumption, which can be almost double normal consumption.



Figure 15-1. A variable exhaust nozzle used to increase or decrease exhaust flow during after burn.

## WATER INJECTION SYSTEM

Before high bypass turbofan engines, some older types of engines used water injection to increase thrust for takeoff (wet). This is the maximum allowable thrust for takeoff. The rating is obtained by actuating the water-injection system and setting the computed wet thrust with the throttle, in terms of a predetermined turbine discharge pressure or engine pressure ratio for the prevailing ambient conditions. The rating is restricted to takeoff, is time-limited, and has an altitude limitation. Water injection is not used very much on turbine engines any more.

On warm days, thrust is reduced because of the decrease in air density. This can be compensated for by injecting water at the compressor inlet or diffuser case. This lowers the air temperature and increases air density. A microswitch in the fuel control is actuated by the control shaft when the power lever is moved toward the maximum power position.

A water injection speed reset servo resets the speed adjustment to a higher value during water injection. Without this adjustment, the fuel control would decrease rpm so that no additional thrust would be realized during water injection. The servo is a shuttle valve that is acted upon by water pressure during water injection. Movement of the servo displaces a lever on the cam-operated lever linkage to the speed governor speeder spring, increasing the force of the speeder spring and increasing the set speed. Because the resulting rpm is usually higher while water is flowing, increased thrust during water injection is ensured. If the water injection system is not armed in the cockpit or if there is no water available, nothing happens when the water injection switch in the fuel control unit is actuated. When water is available, a portion of it is directed to the water injection speed re-set servo.

Water injection systems are not normally used on high-bypass turbofan engines.

Note that some water injection systems use a water methanol mixture. The methanol acts as an anti-freeze for the water while it is in the storage reservoir. Methanol also burns in the engine combustion chamber thus contributing to the production of thrust.



**Question: 15-1**

A power augmentation system such as an afterburner is used to increase \_\_\_\_\_.

**Question: 15-3**

There are two principle problems related to afterburner systems; \_\_\_\_\_ and \_\_\_\_\_.

**Question: 15-2**

Reduced thrust on warm days can be increase by \_\_\_\_\_ which lowers air inlet temperature and, thus increases air density for better performance.

**Question: 15-4**

How is rpm maintained during a water injection cycle?

## ANSWERS

*Answer:* 15-1  
thrust.

*Answer:* 15-3  
Extreme heat in the exhaust ducts; very high fuel flow rates.

*Answer:* 15-2  
water injection.

*Answer:* 15-4  
Additional water pressure on a servo lever adjusts the speed governor to allow higher rpm.



PART-66 SYLLABUS LEVELS  
 CERTIFICATION CATEGORY → A1 B1

**Sub-Module 16**  
**TURBO-PROP ENGINES**

Knowledge Requirements

*15.16 - Turbo-prop Engines*

- Gas coupled/free turbine and gear coupled turbines;
- Reduction gears;
- Integrated engine and propeller controls;
- Overspeed safety devices.

CERTIFICATION CATEGORY →	A1	B1
	1	2

**Level 1**

A familiarization with the principal elements of the subject.

*Objectives:*

- (a) The applicant should be familiar with the basic elements of the subject.
- (b) The applicant should be able to give a simple description of the whole subject, using common words and examples.
- (c) The applicant should be able to use typical terms.

**Level 2**

A general knowledge of the theoretical and practical aspects of the subject and an ability to apply that knowledge.

*Objectives:*

- (a) The applicant should be able to understand the theoretical fundamentals of the subject.
- (b) The applicant should be able to give a general description of the subject using, as appropriate, typical examples.
- (c) The applicant should be able to use mathematical formula in conjunction with physical laws describing the subject.
- (d) The applicant should be able to read and understand sketches, drawings and schematics describing the subject.
- (e) The applicant should be able to apply his knowledge in a practical manner using detailed procedures.

TURBO-PROP ENGINES

## TURBOPROP ENGINES

The turboprop (turbo-propeller) engine is a combination of a gas turbine engine, reduction gear box, and a propeller. (*Figure 16-1*) Turboprops are basically gas turbine engines that have a compressor, combustion chamber(s), turbine, and an exhaust nozzle (gas generator), all of which operate in the same manner as any other gas turbine engine. However, the difference is that the turbine in the turboprop engine usually has extra stages to extract energy to drive the propeller.

### GEAR COUPLED / FIXED TURBINE AND FREE TURBINE

There are two types of multiple stage turbine configurations in turboprop engines: gear coupled, also known as fixed turbine and free turbine. In a gear coupled/fixed turbine engine, all turbine stages are connected to a single shaft. This shaft not only turns the engine compressor but also turns the propeller through a gear reduction gearbox. In a free turbine, the turbine stages are connected to two completely independent shafts. One shaft turns the engine compressor. The second shaft turns the propeller through a reduction gearbox. Although three turbines are typical, as many as five turbine stages have been used for driving the two rotor elements, propeller, and accessories.

Both of these configurations have been used successfully in turboprop engine design. An example of a fixed turbine engine is the Garrett TPE331 turboprop. (*Figure 16-2*)

An example of a free turbine turboprop engine is the popular Pratt and Whitney PT6 engine, the configuration of which is shown in *Figure 16-3*.

Turboprop engines are used for many single, twin, and commuter aircraft. (*Figure 16-4*) Smaller turboprop engines, such as the PT-6, are used on single and twin engine designs; the power ranges from 500 to 2 000 shaft horsepower.

Large commuter aircraft use turboprop engines, such as the P&W 150 and AE2100 that can deliver up to 5 000 shaft horsepower to power mid-sized to large turboprop aircraft. (*Figure 16-5*) The turboprop powerplant has proved to be an extremely efficient power source.

### TURBOPROP CONTROLS

The turboprop fuel control and the propeller governor are connected and operate in coordination with each other. The power lever directs a signal from the cockpit to the fuel control for a specific amount of power from the engine. The fuel control and the propeller governor together establish the correct combination of rpm, fuel flow, and propeller blade angle to create sufficient propeller thrust to provide the desired power.

The propeller control system is divided into two types of control: one for flight and one for ground operation. For flight, the propeller blade angle and fuel flow for any given power lever setting are governed automatically



Figure 16-1. A PT-6 turboprop engine.

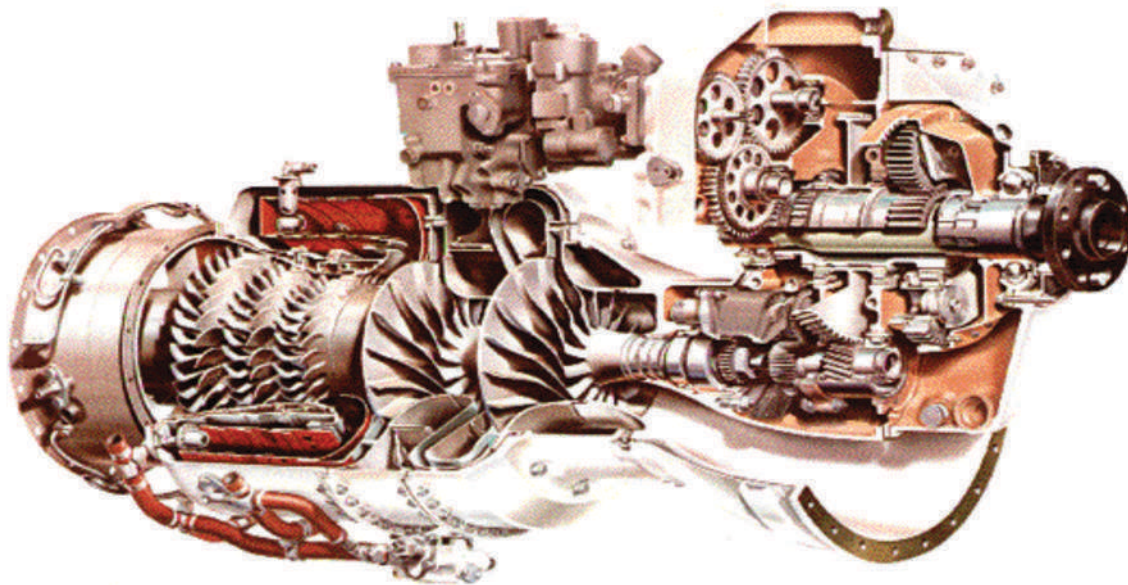

Figure 16-2. A cutaway drawing of a fixed turbine or gear coupled turboprop engine.

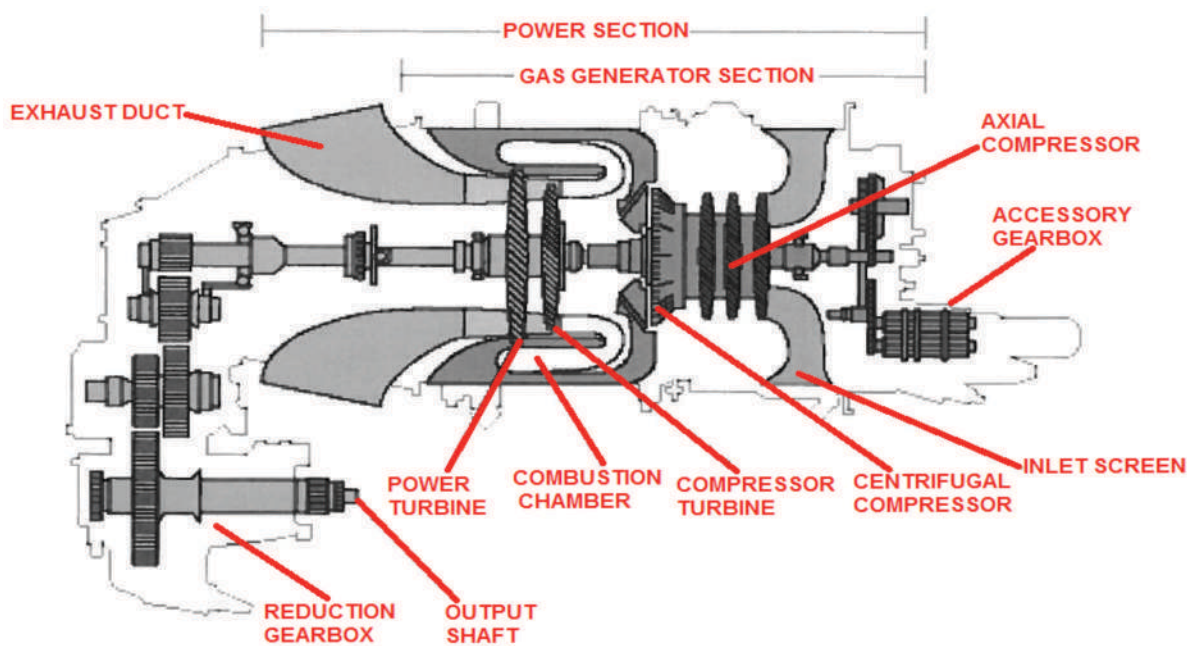

Figure 16-3. Diagram of a free turbine turboprop engine.

according to a predetermined schedule. Below the "flight idle" power lever position, the coordinated rpm blade angle schedule becomes incapable of handling the engine efficiently. Here, the ground handling range, referred to as the beta range, is encountered. In the beta range of the throttle quadrant, the propeller blade angle is not governed by the propeller governor, but is controlled by the power lever position. When the power lever is moved below the start position, the propeller pitch is reversed to provide reverse thrust for rapid deceleration of the aircraft after landing.

A characteristic of the turboprop is that changes in power are not related to engine speed, but to turbine inlet temperature. During flight, the propeller maintains a constant engine speed. This speed is known as the 100 percent rated speed of the engine, and it is the design speed at which most power and best overall efficiency can be obtained. Power changes are effected by changing the fuel flow. An increase in fuel flow causes an increase in turbine inlet temperature and a corresponding increase in energy available at the turbine. The turbine absorbs more energy and transmits it to the propeller in the form





Figure 16-4. Turboprop commuter.



Figure 16-6. Reduction gearbox.



Figure 16-5. Pratt & Whitney 150 turboprop engine.

of torque. The propeller, in order to absorb the increased torque, increases blade angle, thus maintaining constant engine rpm with added thrust.

## REDUCTION GEAR ASSEMBLY

The function of the reduction gear assembly is to reduce the high rpm from the engine to a propeller rpm that can be maintained without exceeding the maximum propeller tip speed (speed of sound). Most reduction gear assemblies use a planetary gear reduction. (Figure 16-6) Additional power takeoffs are available for propeller governor, oil pump, and other accessories. A propeller brake is often incorporated into the gearbox. The propeller brake is designed to prevent the propeller from windmilling when it is feathered in flight, and to decrease the time for the propeller to come to a complete stop after engine shutdown.

## TURBO-PROPELLER ASSEMBLY

The turbo-propeller provides an efficient and flexible means of using the power of the engine at any condition in flight (alpha range). (Figure 16-7) For ground handling and reversing (beta range), the propeller can be operated to provide either zero or negative thrust. The major subassemblies of the propeller assembly are the barrel, dome, low-pitch stop assembly, over speed governor, pitch control unit, auxiliary pump, feather and unfeather valves, torque motor, spinner, deice timer, beta feedback assembly, and propeller electronic control. Modern turboprop engines use dual Full Authority

Digital Engine Control (FADEC) to control both engine and propeller. The spinner assembly is a cone-shaped configuration that mounts on the propeller and encloses the dome and barrel to reduce drag.

The synchrophasing system is designed to maintain a preset angular relationship between the designated master propeller and the slave propellers. Propeller operation is controlled by a mechanical linkage from the cockpit-mounted power lever and the emergency engine shutdown handle (if the aircraft is provided with one) to the coordinator, which, in turn, is linked to the propeller control input lever. Newer designs use electronic throttle control that is linked to the FADEC controller.

Turbo-propeller control assemblies have a feathering system that feather the propeller when the engine is shut down in flight. The propeller can also be unfeathered during flight, if the engine needs to be started again. Propeller control systems for large turboprop engines differ from smaller engines because they are dual acting, which means that hydraulic pressure is used to increase and decrease propeller blade angle. (Figure 16-8)

## OVER SPEED SAFETY DEVICES

Over speed is the condition in which the actual engine speed is higher than the desired engine speed is set on the propeller control by the pilot. An over speed governor is a backup for the propeller governor and is mounted on the reduction gearbox. It has its own flyweights and pilot valve, and it releases oil from the propeller whenever the propeller RPM exceeds a preset limit above 100%. Releasing the oil shows the blades to move to a higher pitch angle, which reduces the RPM. The over speed governor is adjusted when installed and cannot be adjusted in flight-there are no cockpit controls for it.

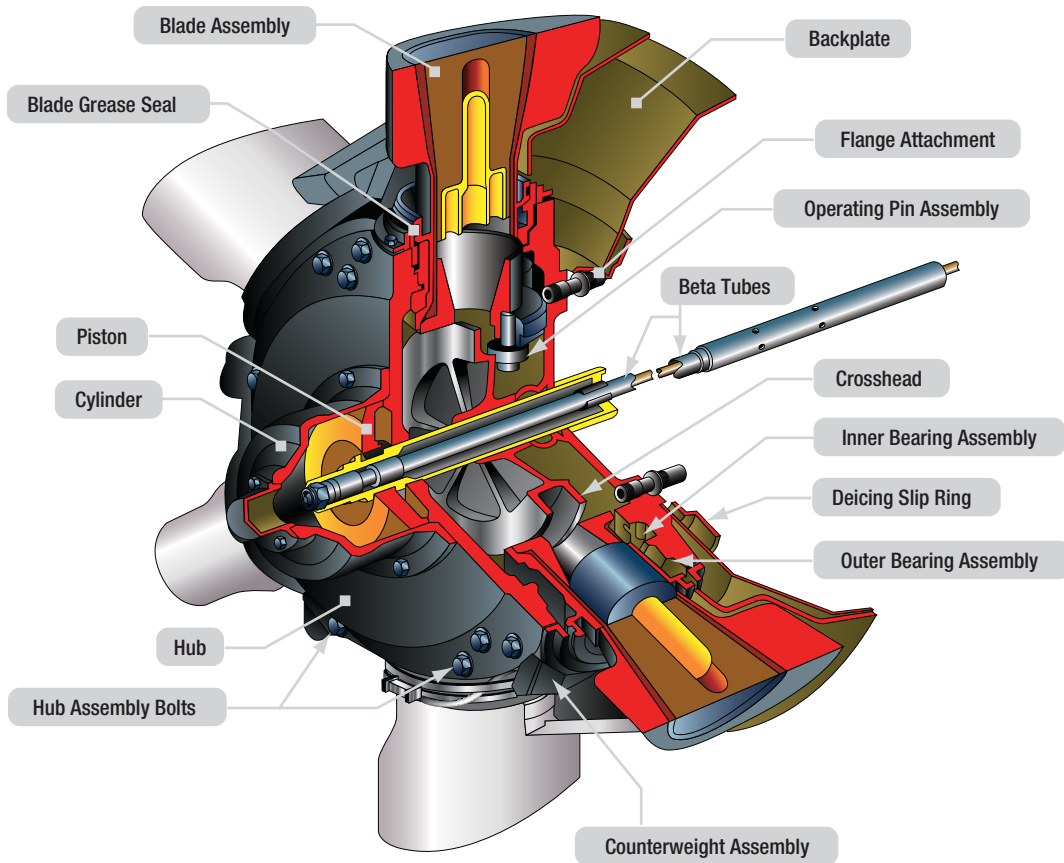

Figure 16-7. A turboprop propeller hub assembly.

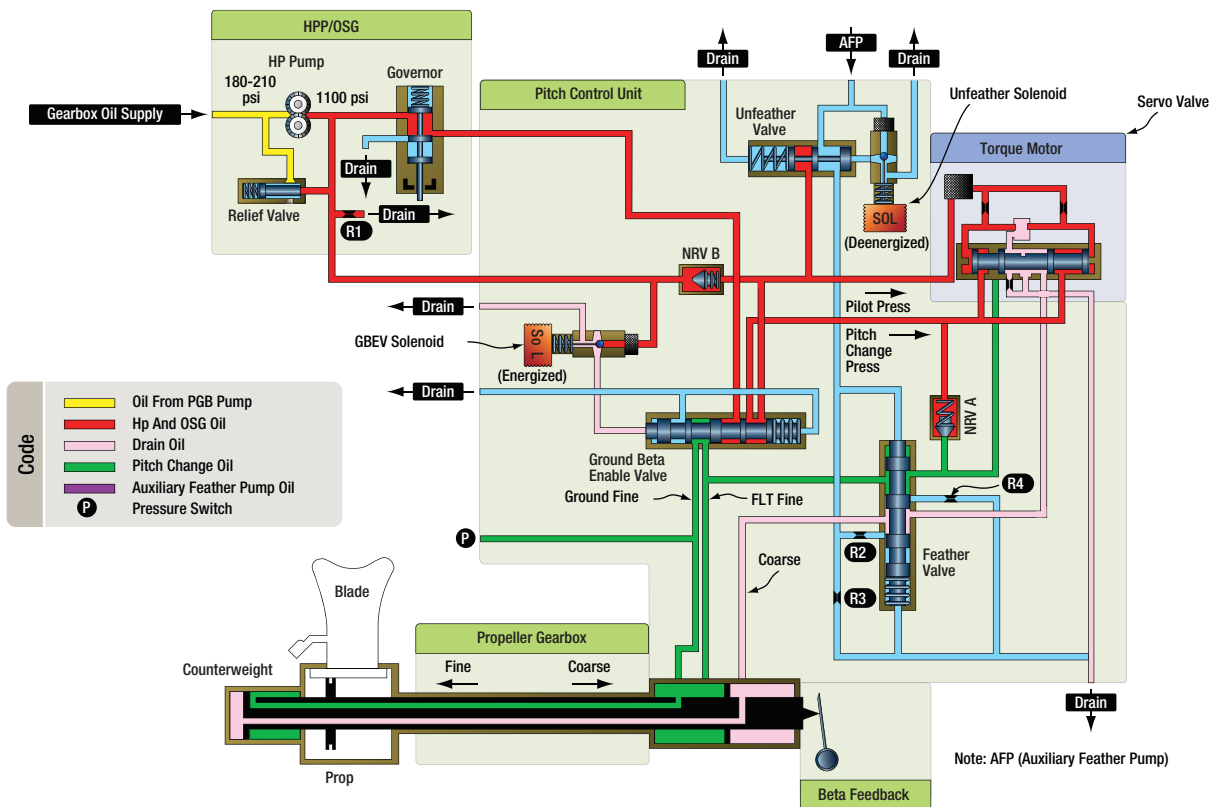

Figure 16-8. Propeller control system schematic.



*Question:* 16-1

A difference between a turbo prop engine and other gas turbine engines is that the turbine in the turboprop engine has \_\_\_\_\_ to extract energy to drive the propeller.

*Question:* 16-5

In a free turbine engine such as a P&W PT-6, what drives the propeller?

*Question:* 16-2

In the beta range of the throttle quadrant, the propeller blade angle is not governed by the propeller governor, but is controlled by the \_\_\_\_\_.

*Question:* 16-6

What two things are simultaneously controlled by the power lever in a Turboprop engine when in flight?

*Question:* 16-3

Turbo-propeller control assemblies have a feathering system that feather the propeller when \_\_\_\_\_.

*Question:* 16-7

What aspect of operation always remains constant on a turboprop engine when in flight?

*Question:* 16-4

An \_\_\_\_\_ is a backup for the propeller governor and is mounted on the reduction gearbox.

*Question:* 16-8

A propeller brake will only operate when the engine is in what operational condition?

## ANSWERS

*Answer:* 16-1  
extra stages.

*Answer:* 16-5  
Gas pressure developed by the turbine section.

*Answer:* 16-2  
power lever position.

*Answer:* 16-6  
Fuel flow and propeller blade angle.

*Answer:* 16-3  
the engine is shut down in flight.

*Answer:* 16-7  
Engine speed (rpm).

*Answer:* 16-4  
over speed governor.

*Answer:* 16-8  
When the engine is shut down (turned off).



PART-66 SYLLABUS **LEVELS**  
 CERTIFICATION CATEGORY → **A1** **B1**

**Sub-Module 17**  
**TURBO-SHAFT ENGINES**  
 Knowledge Requirements

*15.17 - Turbo-shaft Engines*

Arrangements, drive systems, reduction gearing, couplings, control systems.

CERTIFICATION CATEGORY →	A1	B1
	1	2

**Level 1**

A familiarization with the principal elements of the subject.

*Objectives:*

- (a) The applicant should be familiar with the basic elements of the subject.
- (b) The applicant should be able to give a simple description of the whole subject, using common words and examples.
- (c) The applicant should be able to use typical terms.

**Level 2**

A general knowledge of the theoretical and practical aspects of the subject and an ability to apply that knowledge.

*Objectives:*

- (a) The applicant should be able to understand the theoretical fundamentals of the subject.
- (b) The applicant should be able to give a general description of the subject using, as appropriate, typical examples.
- (c) The applicant should be able to use mathematical formula in conjunction with physical laws describing the subject.
- (d) The applicant should be able to read and understand sketches, drawings and schematics describing the subject.
- (e) The applicant should be able to apply his knowledge in a practical manner using detailed procedures.

TURBO-SHAFT ENGINES

---

## TURBOSHAFT ENGINES

A turboshaft engine is optimized to produce shaft power rather than jet thrust. In concept, turboshaft engines are very similar to turboprops, with a basic single engine design provided in both forms. Turboshaft engines come in many different styles, shapes, and horsepower ranges. (*Figure 17-1*) The output shaft may be coupled directly to the engine turbine, or the shaft may be driven by a turbine of its own (free turbine) located in the exhaust stream. As mentioned with the turboprop, the free turbine rotates independently. This principle is used extensively in current production of turboshaft engines. The turboshaft engine's output is measured in horsepower instead of thrust because the power output is a turning shaft.

A turboshaft engine may be made up of two major parts assemblies: the 'gas generator' and the 'power section'. The gas generator consists of the compressor, combustion chambers with ignitors and fuel nozzles, and one or more stages of turbine. The power section consists of additional stages of turbines, a gear reduction system, and the shaft output. The gas generator creates the hot expanding gases to drive the power section. Depending on the design, the engine accessories may be driven either by the gas generator or by the power section. (*Figure 17-2*)

Turboshaft engines are commonly used in applications that require a sustained high power output, high reliability, small size, and light weight. In aviation, these include helicopters and auxiliary power units (APUs). Basic arrangements are similar to turboprops except the drive systems are more elaborate. For example over-running clutches allow for autorotation in case of power loss. Additionally, twin helicopters drive a single transmission with clutches allowing for single engine operation if required.

### REDUCTION GEARING

About two thirds of the energy produced by a helicopter turboshaft engine is used to operate the gas generator. The remaining one third is extracted to drive the high ratio reduction gearbox which in a helicopter is called a transmission. Helicopter rotors tend to rotate at only 300–400 rpm. This is the reduction from approximately 35 000 rpm of the turbine shaft.

### COUPLINGS AND DRIVE SYSTEMS

Most turbine helicopters make use of a short shaft system to deliver power to the transmission. These short shafts vary in design, but all have some way to correct for misalignment and for movement of the transmission. Some of these shafts operate with no lubrication, while others require it. This lubrication is usually in the form of grease and is often hand packed.

The drive shaft consists of a shaft with two flexible couplings attached at each end. The shaft turns at high speed (6 000 to 30 000 rpm). Therefore, balance is important. The drive shaft itself must also be provided with flexibility for the deflection caused by the transmission movements, but will not carry any tension or compression loads because of the housing. The flexible coupling allows for small movements between the engine(s) and the transmission.

A freewheeling unit or over-running clutch is located somewhere between the engine and the main rotor shaft to allow for autorotation without the rotor driving the engine. A seizure of the engine could prevent the autorotation. A spray clutch is commonly used on the engine output shaft for this purpose.

### CONTROL SYSTEMS

Power control of helicopter engine is regulated via a hand throttle (twist grip) built into the side collective stick. The collective stick, when raised, will increase the angle of attack of all rotor blades at the same time. As this will increase drag, the rotor assembly will tend to slow. The fuel system increases engine power to match the load change at the main rotor through the use of a flyweight controlled free turbine governor. The governor modulates the flow of fuel to the combustion section of the engine.

On some turbine engine helicopters the twist grip arrangement has been eliminated in favor of a power lever for the free turbine. The N1 usually has three positions: ground idle, flight idle and full N1. The N1 system will speed up and slow down as a function of N2 so a steady rotor rpm may be maintained during all flight conditions.

Like fuel controls for turbojet and turbofan engines, the fuel control for a turbo-shaft engine receives a signal from the pilot for a given level of power. The control then takes certain variables into consideration. It adjusts the engine fuel flow to provide the desired power without exceeding the rpm and turbine inlet temperature limitations of the engine. The power plant is controlled between ground and flight idle by the throttle twist grip. Between flight idle power and maximum power, control is automatic by the free turbine governor.

Modern turboshaft helicopter engines have electronic engine controls (EEC) and FADEC controlled engines.

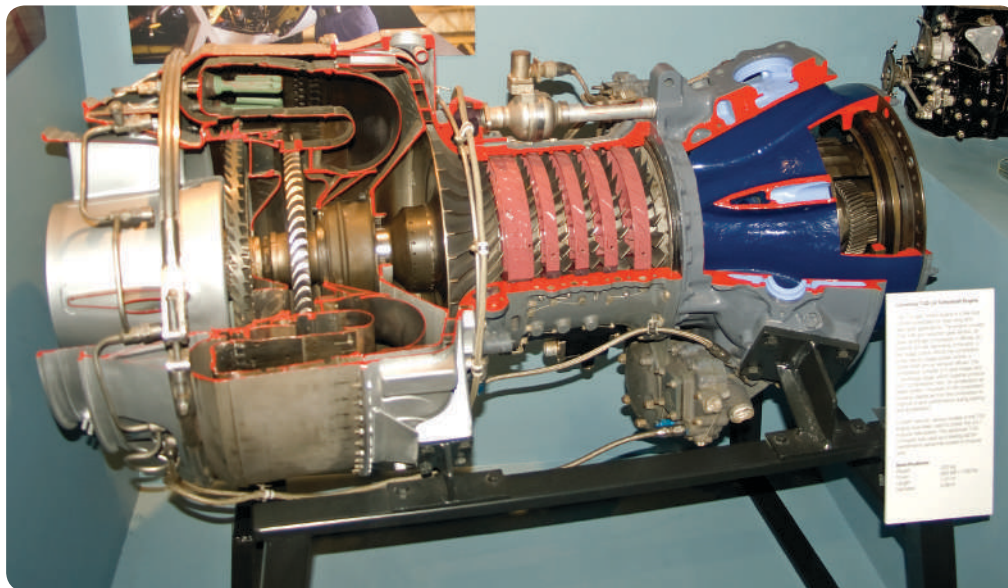

Figure 17-1. A cutaway of a Lycoming T-53-L9 turboshaft engine.

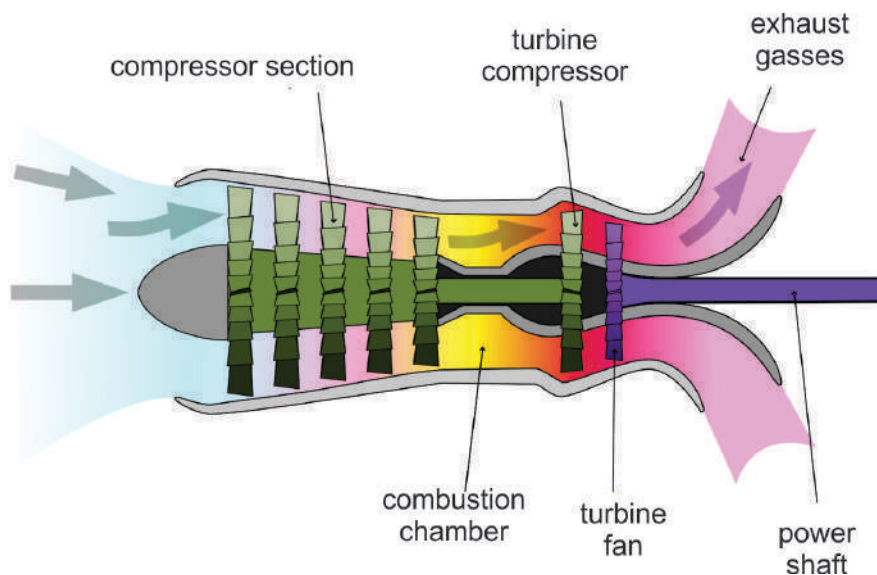

Figure 17-2. Schematic diagram showing the operation of a simplified turboshaft engine. The compressor spool is shown in green and the free/power spool is in purple.

TURBO-SHAFT ENGINES





**Question:** 17-1

On a turboshaft engine, the output shaft may be coupled directly to the engine turbine, or the shaft may be driven by a turbine of its own. The latter is known as a \_\_\_\_\_.

**Question:** 17-3

At what rpm would a Spray clutch engage on a turboshaft engine?

**Question:** 17-2

On turboshaft engines, movement of the throttle adjusts the engine fuel flow to provide the desired power without exceeding the rpm and \_\_\_\_\_ limitations of the engine.

**Question:** 17-4

Turboshaft engines are ideal for helicopter operation because of their \_\_\_\_\_ and \_\_\_\_\_?

## ANSWERS

*Answer: 17-1*  
free turbine.

*Answer: 17-3*  
At zero rpm (in the event of an engine seizure).

*Answer: 17-2*  
turbine inlet temperature.

*Answer: 17-4*  
small size; light weight.



PART-66 SYLLABUS LEVELS  
 CERTIFICATION CATEGORY → A1 B1

**Sub-Module 18**  
**AUXILIARY POWER UNITS (APUS)**  
 Knowledge Requirements

*15.18 - Auxiliary Power Units (APUs)*  
 Purpose, operation, protective systems.

A1	B1
1	2

**Level 1**  
 A familiarization with the principal elements of the subject.

- Objectives:*
- (a) The applicant should be familiar with the basic elements of the subject.
  - (b) The applicant should be able to give a simple description of the whole subject, using common words and examples.
  - (c) The applicant should be able to use typical terms.

**Level 2**  
 A general knowledge of the theoretical and practical aspects of the subject and an ability to apply that knowledge.

- Objectives:*
- (a) The applicant should be able to understand the theoretical fundamentals of the subject.
  - (b) The applicant should be able to give a general description of the subject using, as appropriate, typical examples.
  - (c) The applicant should be able to use mathematical formula in conjunction with physical laws describing the subject.
  - (d) The applicant should be able to read and understand sketches, drawings and schematics describing the subject.
  - (e) The applicant should be able to apply his knowledge in a practical manner using detailed procedures.

AUXILIARY POWER UNITS (APUS)

## AUXILIARY POWER UNITS (APUs)

Auxiliary Power Units or APUs are self-contained turbo-shaft engines in the 55 to 350 SHP (shaft horse power) range. Categorized as either ground or in-flight certified, they are used to provide pneumatic and electrical power to aircraft systems. Installed in almost all modern turbine aircraft, they are primarily used during the following scenarios:

- Main engine starting;
- Main engines not operating;
- In-flight emergencies;
- Ground power support not available;
- Main engine de-loading of bleed air demands.

APUs were originally developed for the electrical requirements of large reciprocating and early turbojet powered aircraft. They used GPU (ground power units) carts with a piston engine and a direct drive generator to provide electrical energy to the main engine's starter motor. With larger engines, more torque is required for start rotation and so more electrical energy. Turbo-shaft engines eventually replaced the piston engines on GPU carts, but the aircraft that required them were still tied to their use and so required them at all airports at which they operated. It thus made sense to install APUs in the aircraft to provide operating flexibility. Doing so also provides an increased margin for flight safety by being a built-in back-up for the generators on the main engines. Passenger comfort was also increased by using the APU provided pneumatic power to operate the air conditioning on the ground with the main engines not operating.

APUs have become the workhorses of modern aviation. Produced by only a handful of manufacturers including Honeywell and Pratt & Whitney/Hamilton Sundstrand, their basic operation, construction, systems, inspection, and maintenance are all very similar to other turbine engine varieties.

### CONSTRUCTION

Most APU's share a common construction divided into three main sections: intake/compression, combustion/turbine, and gear box. The inlet or plenum consists of ducting from an intake door or scoop located on the top or side of the aircraft fuselage. Before the intake air passes into the APU's compressor (*Figure 18-1*), it first passes down the plenum through a FOD and ice screen. Because an APU is primarily a ground operating

engine, it could be very prone to FOD damage by ramp debris if the screen wasn't in place to protect the intake. Most APUs use a centrifugal impeller/radial diffuser combination in either one or two stages to compress the intake air for engine operation and airframe system use. (*Figure 18-2*)

The centrifugal compressor configuration is used for several reasons: it creates a larger pressure rise per stage, it creates a smaller engine area, and is more FOD and surge/stall resistant than axial flow compressors. Some engines use a power compressor for engine operation, and another load compressor to create bleed air. An electrically operated butterfly valve, the load control valve, is used to control the amount of compressed air delivered to the aircraft's pneumatic manifold for airframe system use. The pressure and quantity of airflow delivered depends on the aircraft's needs.

Honeywell's GTCP 131 APU engine can offer air at a pressure of 52 PSI (3.5Bar) and at a flow rate of up to 154 lbs. (70 Kg) per minute. Some engines use a single entry double sided compressor to accomplish both power and load functions with one unit. Surge and stall prevention in the compressor is often accomplished through the use of IGVs (inlet guide vanes) or surge valves. The IGVs help by de-turbulating the inlet air flow, and the surge valve bleeds off compressor pressure should a surge/stall event become eminent.



Figure 18-1. APU intake note FOD/ice screen around impeller.



Figure 18-2. APU centrifugal impeller and drive shaft.

APUs use either a can or annular style combustor, depending on the type of turbine used. Some engines use a radial inflow turbine similar to a reciprocating engine turbocharger unit and are usually used with a can type combustor. Axial flow turbines, like the units used in turbofan and turbojet engines, are often used with an annular type combustor. Even though they are more efficient than other types, can-annular combustors are not typically used due to maintenance and inspection concerns. Single or dual turbine configurations are often used. A single turbine configuration provides horse power to rotate both the compressor and the gear box section. In a dual turbine configuration, one turbine spins the compressor, and the other powers the gear box and its attached accessories.

The APU exhaust is carried overboard through the use of stainless steel ducting located in the tail cone or the side of the empennage. Cooling for the APU can also be accomplished by a device known as an educator. The educator is a convergent duct located around the APU exhaust. Similar to the exhaust augments found on some reciprocating engines, the educator creates a low pressure pulling airflow in and around the APU. Some modern APUs use corrugated perimeter exhaust silencers to reduce the noise of operation.

The APU gearbox is normally located opposite the combustion section with the intake and compressor section in the middle. The gear box is comparable to the accessory gear box of the other turbine engine types. The gearbox not only provides the drive input for the APU's electric starter motor, but it also uses shaft horse power from the turbine to provide rotational energy at a correctly geared RPM. This drives the engine's fuel pump, oil pump, and the APU's generator. Of all the APU's power outputs, the generator's electrical output is the most important to aircraft operation.

The generators used on the APU are varied in size and output, depending on the electrical requirements of the aircraft on which it is installed. A permanent magnet generator is commonly used with an output of 30-90 KVA (kilo volt ampere), creating 115V three phase AC power at 400 Hz to the aircraft's electrical bus. If DC voltage is required, an airframe installed transformer rectifier creates 28V DC for use. The APU's generator is almost always identical to the units installed on the main engines for two reasons; to deliver the same electrical output to the aircraft's electrical grid and to provide an on-aircraft-spare for the main engine generator. A CSD (constant speed drive) hydraulic unit or a VSCF (variable speed constant frequency) converter is not required for APU generators because the engines are not throttleable and run at a constant 90-100% RPM.

In large rotor wing aircraft, the APU often provides a third power output in the form of hydraulic pressure from a multi piston hydraulic pump located on the gearbox. The fluid pressure is used to power a multi-piston hydraulic motor to deliver start RPM to the main engine, transmission, and rotor head assembly.

This can also be done by a hydraulic accumulator being attached to the APU hydraulic pump. A power density only hydraulics can apply is required to provide the shaft horse power input needed, thus bleed air and electric motors are not used for start RPM. (*Figure 18-3*)



Figure 18-3. Honeywell GTCP 331-350 note the pneumatic output duct on the bottom of the engine the top duct is for the oil cooler unit.

## INSTALLATION

APU units are normally located in the empennage of the aircraft, either imbedded in an accessory bay or suspended within the tail cone structure. APUs that are installed in the empennage are typically housed in a specifically designed enclosure. APU enclosures are commonly fabricated from high temperature stainless steel and perform several functions: to provide a sealed space for engine fire suppression and cooling air flow; to reduce noise through the use of sound absorbing materials; and to provide ballistic containment in case of catastrophic engine failure. Ballistic containment is a key factor in determining if an APU can be in-flight certified. An in-flight failure of an APU turbine or compressor, if not contained, could lead to further damage and failures of flight critical systems, which could in turn result in loss of the aircraft. In a tail cone

installation, the APU is suspended within the structure, using a steel mount assembly to a forward firewall with vibrational shock mounts similar to the aircraft's main engines. The tail cone becomes the APU enclosure and provides the same functionality as the imbedded units. Often the tail cone structure is split to create a cowl door for the APU, making installation and removal much easier than in the imbedded configuration.

(Figure 18-4, Figure 18-5 and Figure 18-6)

## ENGINE SYSTEMS

The APU engine systems are separated into four main categories: fuel, oil, starting, and ignition and are very comparable to similar systems on other turbine engine designs. Typically, the feed tank that supplies fuel to the main engines also provides fuel to the APU.

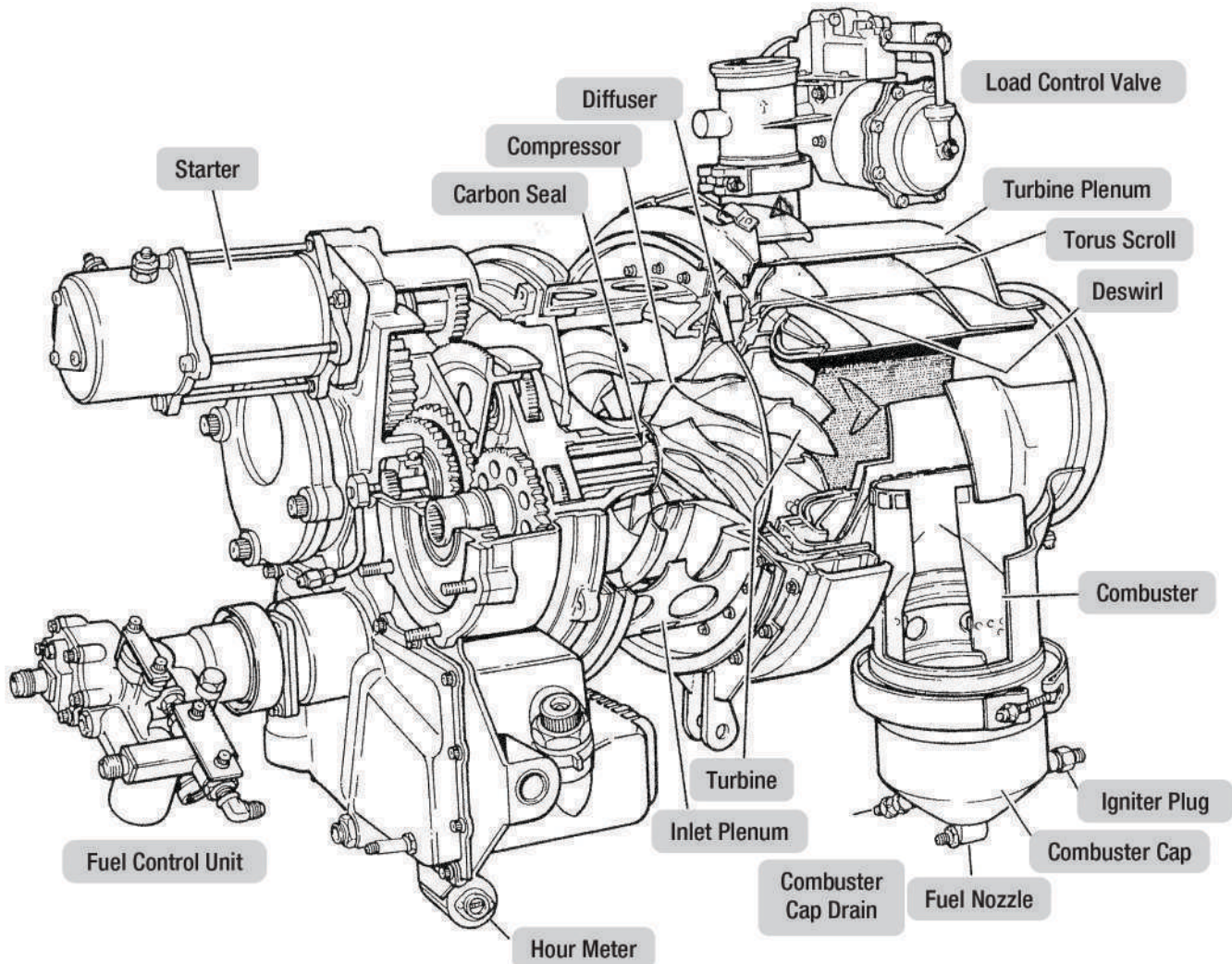

Figure 18-4. Garrett/Honeywell GTCP 36-100G APU cutaway.

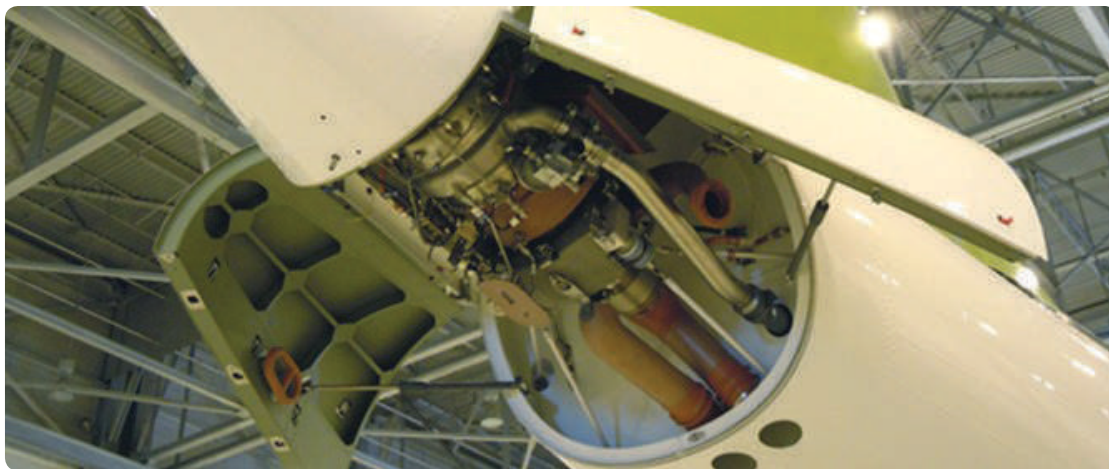

Figure 18-5. typical empennage/tail cone APU installation.

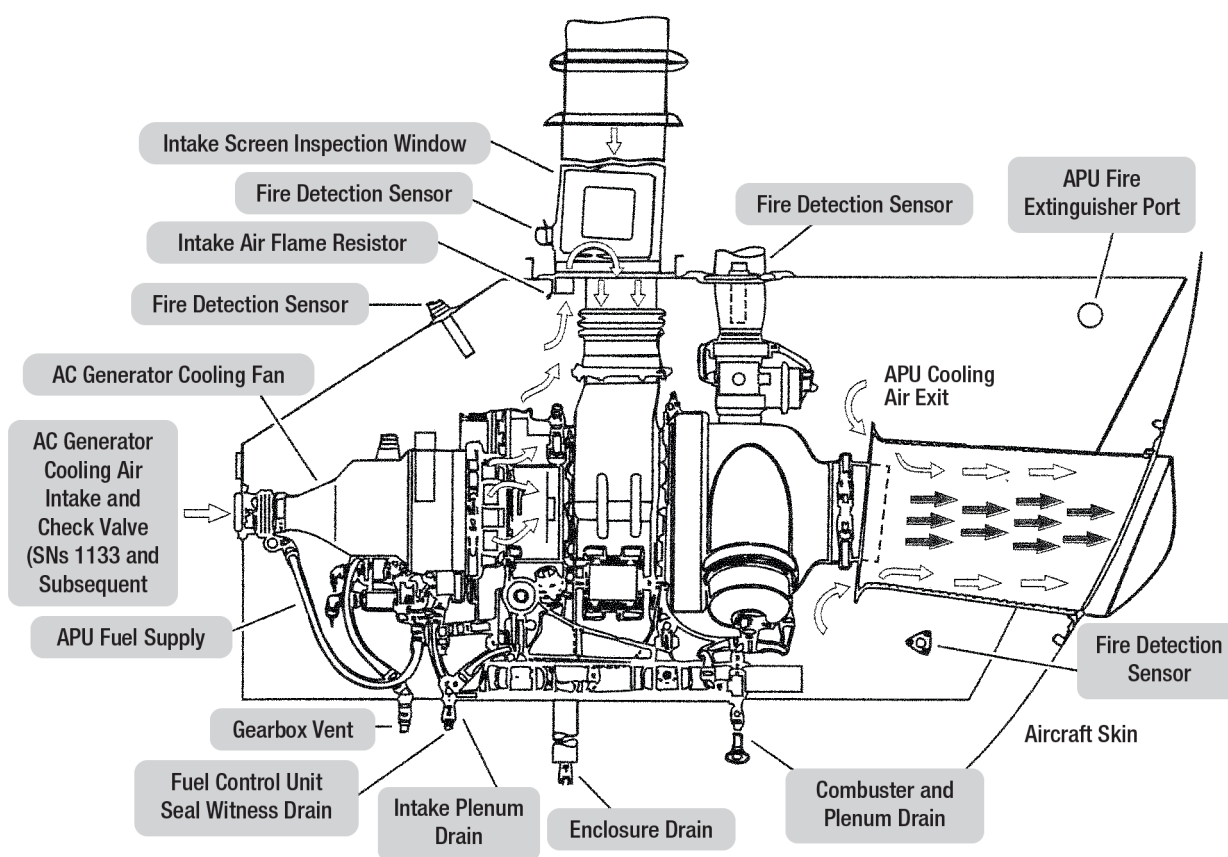

Figure 18-6. Typical empennage imbedded APU installation with enclosure.

Fuel first passes through an electrically operated shut off valve for engine shut down and fire suppression. It is then delivered to the APU fuel control unit (FCU), which is nothing more than a simple high capacity gear pump run by and attached to the APU gearbox. The APU's FCU is the metering portion of a supervisory configuration controlled by the Electronic Engine Control (EEC).

A computerized unit, the EEC monitors all engine parameters and controls all segments of APU operation, including fuel flow metering to maintain the constant RPM required to provide electrical and pneumatic power to the aircraft. The FCU and the EEC can be consolidated into a FADEC (full authority digital engine controller) system to both meter fuel and control the APU. The FCU almost always contains a metal



mesh fuel filter with bypass capability and 7 to 10 microns. Fuel is offered to the combustion chamber normally through the use of a flow divider and a duplex style nozzle that atomizes the fuel for ignition in a can or annular type combustors.

Most turbo-prop and larger turbo-shaft engine APUs utilize a wet sump oil system, containing most all of the oil system components and the oil supply in the gear box. Fuel and oil filter units are almost identical in construction, both using metal mesh elements with bypass capabilities. Oil pressure for cooling and lubricating the bearings is provided by a gear type pump, creating a constant 40 PSI to the oil nozzles. Unlike most primary engine systems, APUs traditionally use an air-to-fluid heat exchanger to cool the oil. Intake air, ram air, or gearbox mounted cooling fans are all commonly used.

APU starting RPM is provided by a 28V DC series starter unit. Electrical power is usually supplied by a designated 28V battery, with charging unit separate from the main aircraft batteries. The starter motor often contains a centrifugal sprag type clutch to disengage the unit from the gearbox at approximately 60% RPM when the engine has become self-sustaining. APU ignition systems consist of a high energy capacitive discharge exciter, a lead, and an igniter plug. The igniter plug is of the surface gap variety, with a discharge potential from 5000-8000 Volts. In a typical APU start sequence, the ignition system is engaged by the APU's EEC (normally at 10% RPM) and disengaged at 95% RPM. Once initiated by flight or ground crew, the EEC handles the entire start sequence automatically.

APUs also have a separate automatic fire detection and a manually discharged suppression system. This system's description and operation is discussed in detail in *Sub-Module 20. (Figure 18-7)*

## APU CONTROL

The APU is almost a fully automated unit. Only start, shutdown, and fire suppression discharge are commanded by the flight or ground crew. The EEC, provides all control, monitoring, and management functions. The EEC is also sometimes referred to as the APCU (Auxiliary Power Control Unit), a computing device that uses internal logic and data base memory and is the brains of the engine.



Figure 18-7. Honeywell GTCP 331-350 note the starter motor at upper left, the ignition exciter box at upper right and the fuel and oil filter units attached to the bottom of the gear box.

The EEC generally has input connections to exhaust gas temperature thermocouple probes, oil, fuel, and pneumatic pressure switches, as well as RPM sensing monopole or magnetic sensors. Using these inputs, it handles all start and shut downs as well as engine cooling. Cooling control is provided by an EEC input to the load control valve. If the engine is overheating, the EEC will restrict bleed flow to the aircraft, keeping it in the APU for secondary combustion cooling air. In all APU configurations, the electrical load output has priority over the pneumatic extraction from the engine. To ensure this, the APU's RPM input to the generator must be preserved. If the EEC senses an over speed event, (typically around 110% RPM), it will close the fuel shut off valve and shutdown the engine. The same protective shutdown will occur if the EEC senses low oil pressure or an overheat event. When a flight or ground crew shut down is commanded, the shutdown switch injects a signal to the EEC, and shuts down the engine.

Because the EEC is a computerized unit, it contains BITE (Built in Test Equipment) to record faults, self-troubleshoot, and monitor systems operation. BITE information is readily available to maintenance technicians through either displays on the EEC unit or on the EICAS (Engine Indicating and Crew Alerting System) display in the cockpit. The EICAS display can only be used if the EEC unit has full digital interface with the airframe's network. Another way to access the APU BITE data is with the aircraft's central maintenance computer. This BITE function greatly aids maintenance personnel in rapidly diagnosing a problem with the APU and its associated systems.

The EEC/APCU is usually a standard ARINC (Aeronautical Radio Incorporated) LRU (Line Replaceable Unit) located in the airframe's avionics bay or equipment rack. Two units are generally installed; one is primary, and the other is backup. Newer APU models with FADEC have the EEC actually combined with the FCU in a common housing attached to the APU gearbox. (Figure 18-8)

## CREW CONTROL AND MONITORING

Crew input to the APU is given through an APU control panel located in the cockpit. Transport category aircraft often have a secondary control unit located on the nose landing gear (see Figure 20-22). Control is limited to the APU master, start, and shutdown. The APU master switch "ON/OFF" controls power to the APU EEC unit. Once on, the EEC can then receive the start command from the cockpit and begin the sequence. Starting is fully automated by the EEC that controls the fuel, starter motor, and ignition unit.

The crew can monitor the APU start sequence through the use of RPM and EGT gauges on the panel or by accessing the APU information page on the EICAS system. If installed, the remote operation panel will not contain any monitoring devices; but only start, shutdown, and fire discharge switching. Once the APU is running at full RPM, the generator can then be brought online through the use of switching and relays to deliver electrical power to the aircraft busses. Separate switching on the APU panel opens the load control valve and delivers pneumatic power to the aircraft's manifolds for uses such as main engine starting, anti-icing, cabin pressurizing, water system pressurizing, and cabin cooling. Generator voltage output and pneumatic duct pressure values can be found on the APU panel instrumentation or EICAS as secondary information. (Figure 18-9)

## FLIGHT CERTIFIED APUS

An APU's usefulness to the aircraft and operational safety dramatically increases when the APU is in-flight certified. There are many certification standard in regards to engine performance that an APU has to meet to qualify for in-flight operation. Two of the largest differences between ground and in-flight APUs are ballistic containment and ram air intake. Flight critical systems cannot fail in flight due to FOD created by debris due to an internal engine failure.

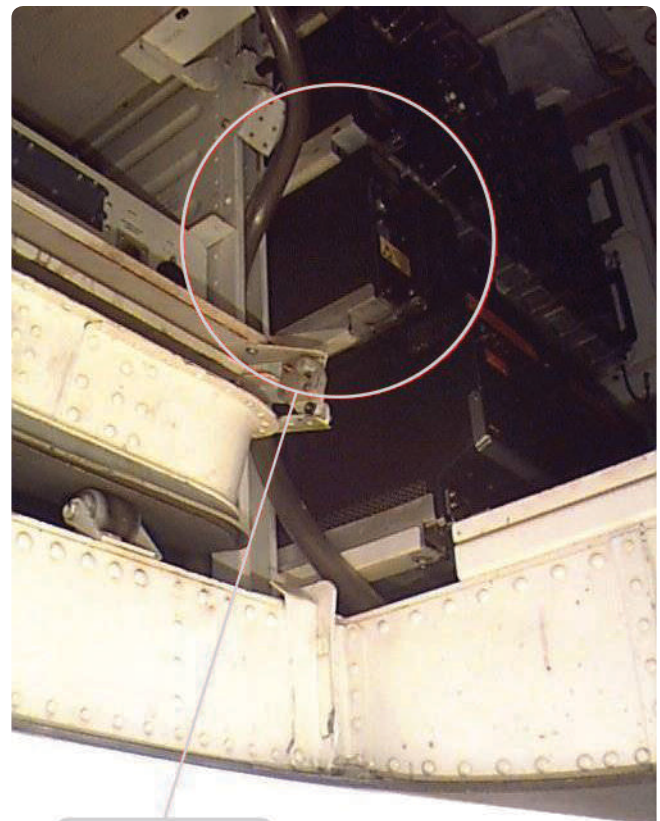

APU Control Unit

Figure 18-8. APU EEC location in an aircraft's forward avionics bay.



Figure 18-9. A typical APU overhead control/monitoring panel.

The ram air scoop is necessary to deliver intake air to the APU and prevent degradation of engine performance while operating in the low air density environment of high altitude flight. In-flight APUs usually require a lower starting altitude (around 15 000 to 17 000 ft. to ensure enough primary/combustion air and secondary/cooling air for start but are then capable of operation up to 40 000 ft. altitude.

ETOPS (Extended Twin Operational Performance) is a certification granted to twin engine aircraft that requires the ability to travel routes that are much further from emergency landing fields than traditional flight routes. This certification allows for more efficient long range flight routes. One of the primary requirements to achieve this certification is the aircraft's possession of an in-flight APU. Should an in-flight main engine shut down occur, the APU can then shoulder the electrical and pneumatic load from the lost engine. Having this capability on board the aircraft creates an increased margin of safety during single engine operation and permits the aircraft to travel further from potential landing sites.

Depending on the ETOPS certification standards for specific installations, the APU may be required to run continuously when the aircraft is flying an ETOPS route. Most modern installations, however, are meeting criteria to obtain an on-demand authorization, allowing the APUs to be run only if a main engine shutdown occurs. This saves large amounts of fuel and reduces the wear on the APU.

In-flight, APUs are often started during an aircraft's landing phase. This de-loads the main engine's pneumatic burden and allows the engine to keep compressor air to use for reserve thrust should an aborted landing or a go around emergency event occur.

## INSPECTION AND SERVICING

All APU inspection, service, and maintenance must be performed in accordance with OEM guidelines. Most APU maintenance is performed "on-condition," meaning as failure or faults deem necessary. Most inspections are performed on an hourly bases. In-service time is tracked by APU operational hours through the use of a Hobbs or hour meter. APUs require several cold and hot section inspections prior to an overhaul. Because of an APU's frequent use, it is not uncommon to remove it from the aircraft prior to the required hours. Most maintenance and inspections can be performed with the APU installed in the aircraft. Because of their essential service, OEMs often design APUs to be removed with a minimum of time, personnel, and equipment. There are usually limited connections to the aircraft: electrical, fuel, intake, and exhaust, which makes it very simple. Depending on the aircraft design, it is not unusual to remove an APU engine in under 30 minutes.

Cold section inspections require the partial disassembly and visual examination of the APU's compressor section and components. In-field repairs of most compressors are not permitted and require the engine to be removed from the aircraft and returned to the OEM or an approved service center for repairs. A hot section inspection requires the partial disassembly and visual examination of the turbine and combustion components. Die penetrant and other non destructive testing methods are often used to locate cracking around burner welds as well as turbine and compressor stress points. APU hot section components are time limited and are often removed from the engines to provide an improved margin of safety anywhere from 3 000 to 9 000 hours of operation. (*Figure 18-10*)

Servicing of APUs consist of several tasks: starter motor brush, oil filter, and fuel filter changes; chip detector inspection; gear box oil changes; and spectrometric oil analysis to name a few. Like inspections, all servicing items are accomplished on an hourly basis and should be recorded in the APU logbook. Because of their importance to flight operations, it is critical that maintenance technicians be vigilant with APU maintenance. APUs can continue to be the workhorses modern aircraft need to ensure flight crew and passenger safety by technicians adhering to OEM guidelines and understanding basic APU systems and construction.



Figure 18-10. A typical APU hot section partially disassembled.

*Question:* 18-1

Name 4 standard uses of APU?

*Question:* 18-5

An APU typically has only 3 control functions and two monitoring instruments. What are they?

*Question:* 18-2

How is an APU protected from FOD damage?

*Question:* 18-6

What two criteria must an APU meet in order to be certified for in-flight operation?

*Question:* 18-3

A load compressor is dedicated to providing \_\_\_\_\_ to the aircraft.

*Question:* 18-7

Who is permitted to perform repairs to an APU compressor?

*Question:* 18-4

How is an APU engine's rpm throttled (regulated)?

*Question:* 18-8

Why is an APU typically turned on prior to landing?

## ANSWERS

*Answer:* 18-1

Main engine starting.  
Inflight emergencies.  
Ground support electrical power.  
When main engines need to de-load bleed air.

*Answer:* 18-5

Controls are electronic engine control master switch, start, shutdown. Gauges are RPM and exhaust gas temperature.

*Answer:* 18-2

A screen is installed over the air inlet.

*Answer:* 18-6

Ballistic containment in case of catastrophic failure  
Ram air intake scoop for high altitude operation.

*Answer:* 18-3

pneumatic air.

*Answer:* 18-7

The original equipment manufacturer.

*Answer:* 18-4

It is not. It's preset at a constant 90-100% RPM.

*Answer:* 18-8

To take over the main engine's pneumatic burden and thus allow full engine power in case of an aborted landing.



PART-66 SYLLABUS **LEVELS**  
 CERTIFICATION CATEGORY → **A1** **B1**

**Sub-Module 19**  
**POWERPLANT INSTALLATION**  
 Knowledge Requirements

*15.19 - Powerplant Installation*

Configuration of firewalls, cowlings, acoustic panels, engine mounts, anti-vibration mounts, hoses, pipes, feeders, connectors, wiring looms, control cables and rods, lifting points and drains.

CERTIFICATION CATEGORY →	A1	B1
	1	2

**Level 1**  
 A familiarization with the principal elements of the subject.

- Objectives:*
- (a) The applicant should be familiar with the basic elements of the subject.
  - (b) The applicant should be able to give a simple description of the whole subject, using common words and examples.
  - (c) The applicant should be able to use typical terms.

**Level 2**  
 A general knowledge of the theoretical and practical aspects of the subject and an ability to apply that knowledge.

- Objectives:*
- (a) The applicant should be able to understand the theoretical fundamentals of the subject.
  - (b) The applicant should be able to give a general description of the subject using, as appropriate, typical examples.
  - (c) The applicant should be able to use mathematical formula in conjunction with physical laws describing the subject.
  - (d) The applicant should be able to read and understand sketches, drawings and schematics describing the subject.
  - (e) The applicant should be able to apply his knowledge in a practical manner using detailed procedures.

POWERPLANT  
INSTALLATION

## POWERPLANT INSTALLATIONS

The engine and its necessary accessories, including the gearbox, fuel control, intake cowling, exhaust, thrust reverser assembly, fire protection equipment, sensors, generators, ducting, wiring, cowling, mounts, control cables and rods, drains and firewalls are referred to as the powerplant. Essentially, everything associated with the engine on the engine side of the firewall is part of the powerplant installation.

There are many powerplant installation configurations. Most notable is the wing-mounted powerplant installation which dominates current air transport category aircraft design. Fuselage mounted powerplant installations are also common using turbine engines. Business class aircraft often use this design and benefit from having thrust developed close to the longitudinal axis. Other configurations exist. No matter where

the engines are mounted on the airframe, all turbine engine powerplant configurations share the same basic characteristics. In this sub-module various features and maintenance of turbine engine powerplants are considered.

### FIREWALLS

A firewall is a partition between the engine powerplant installation and the aircraft. Its function is to isolate the powerplant from the airframe structure in case of fire and from the heat created during normal engine operation. Firewalls are typically sheet metal shields made from stainless steel or some other high heat resistance metal. A drawing of an engine firewall on a Boeing 737 is shown in *Figure 19-1*.

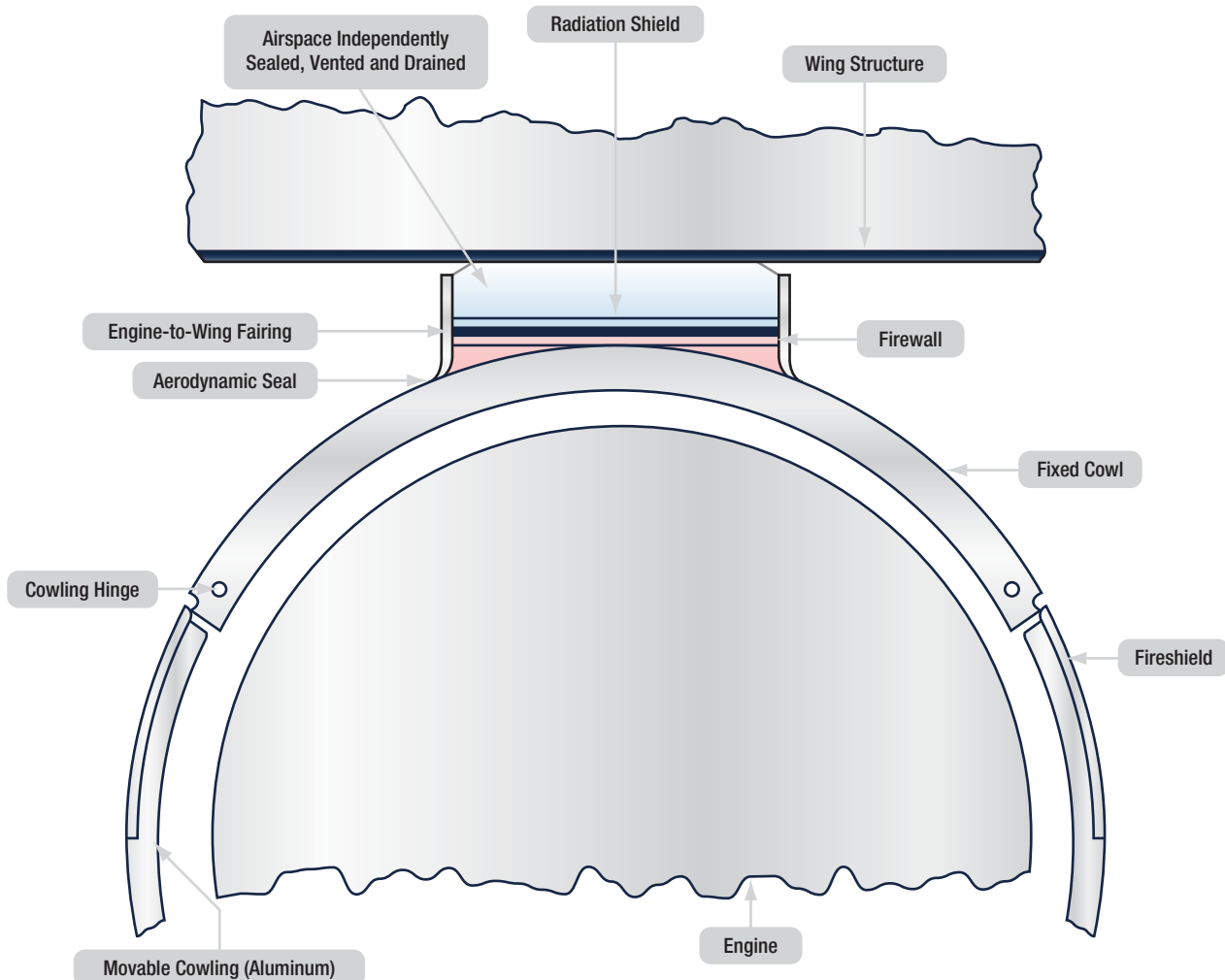

Figure 19-1. Engine firewall.

## COWLING

Nacelles are built around engines to protect the engine and accessories from the operating environment and to provide a streamlined, aerodynamic enclosure with low drag. The nacelle is also designed to route any cooling air effectively around the engine and its components.

Cowling are the fixed and movable panels that make up the nacelle enclosure. Access to the powerplant for maintenance, repair and inspection is frequent. Therefore, nearly all engine cowls are constructed with access for these purposes in mind. Hinged cowling is very common. Secured by a few to several strong latches, a hinged cowl can be opened and closed quickly. It can be swung out of the way so that clear access to a large section of the engine is available. Small access panels for access to a particular part of the powerplant that requires frequent inspection or servicing are also common. Cowling design and construction materials are particular to each engine installation. (*Figure 19-2*)

## ACOUSTIC PANELS

Efforts are made by designers to reduce the noise associated with turbine engine operation. One method of suppressing the noise from the fan stage of a high by-pass ratio engine is to incorporate a noise absorbent liner around the inside wall of the by-pass duct. The lining is comprised of porous face sheeting that inhibits the motion of the sound waves. The depth of the cavity between the absorber and solid backing is tuned to suppress the appropriate part of the noise spectrum.

*Figure 19-3* illustrates two types of noise absorbent liner. A high by-pass ratio engine also may use of a liner to suppress the noise from the engine core.



Figure 19-2. An opened hinged cowling.

The disadvantage of using liners for reducing noise are the addition of weight and the increase in specific fuel consumption caused by increasing the friction of the duct walls.

## MOUNTS FOR TURBOFAN ENGINES

The engine mounts on most turbofan engines perform the same basic functions of supporting the engine and transmitting the loads imposed by the engine to the aircraft structure. Most turbine engine mounts are made of stainless steel in *Figure 19-4*. Some engine mounting systems use two mounts to support the forward end of the engine and a single mount at the rear end.

## TURBINE VIBRATION ISOLATION ENGINE MOUNTS

The vibration isolator engine mounts support the power plants and isolate the airplane structure from adverse engine vibrations. Each power plant is generally supported by forward vibration isolator mounts and an aft vibration isolator mount. The forward vibration isolator engine mounts carry vertical, side, and axial (thrust) loads and allow engine growth due to thermal expansion. The aft mounts take only vertical and side

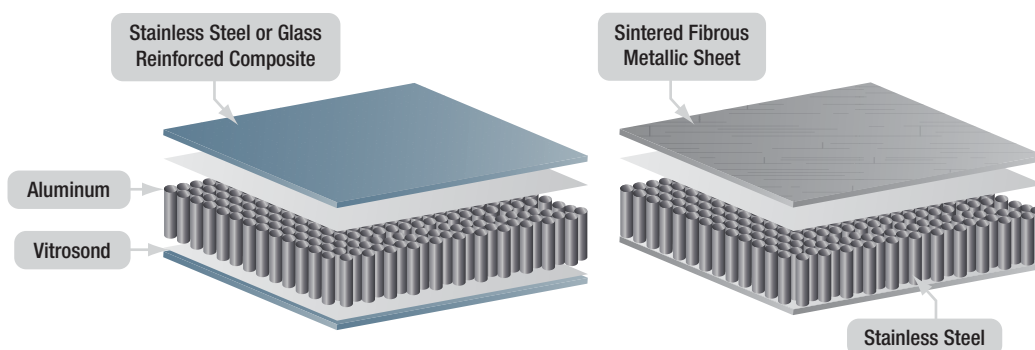

Figure 19-3. Two types of acoustic lining.



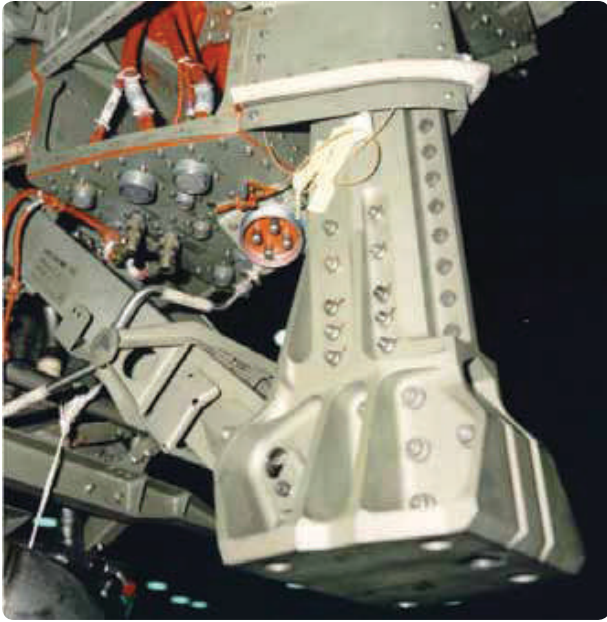

Figure 19-4. Turbine engine front mount.

loads; however, they will also accommodate thermal expansion of the engine without applying axial loads to the engine flanges. The vibration isolators consist of a resilient material permanently enclosed in a metal case. As an engine vibrates, the resilient material deforms slightly, thereby dampening the vibrations before they reach the airplane structure. If complete failure or loss of the resilient material occurs, the isolators will continue to support the engine.

## CONTROL CABLES AND RODS

Control cables and rods are used on many powerplant installation to activate accessories such as the fuel control unit. When changing an engine these components normally remain with the aircraft. Follow the manufacturer's instructions for proper inspection, connection and disconnection of all control cables and rods, especially for the proper adjustment thereof.

## HOSES AND PIPES

Numerous hoses, tubing, pipes, and ducting are all part of an engine installation. Each of these are connected and supported in a very specific manner according to manufacturer's instructions. Technicians should follow all manufacturer's instructions and avoid connecting and supporting these critical power plant elements by what "looks good". Climbing on engines using these installations is highly discourage as well. Use proper engine access stands and ladders.

## FUEL LINES

When fuel system lines are to be replaced or repaired, consider the following fundamentals in addition to the applicable airworthiness requirements. All fittings are to be compatible with their mating parts. Although various types of fittings appear to be interchangeable in many cases they have different thread pitch or minor design differences which prevent proper mating and may cause the joint to leak or fail.

Make sure that the line does not chafe against control cables, airframe structure, etc., or come in contact with electrical wiring or conduit. Where physical separation of the fuel lines from electrical wiring or conduit is impracticable, locate the fuel line below the wiring and clamp it securely to the airframe structure. In no case should wiring be supported by the fuel line.

Alignment is always important. Locate bends accurately so that the tubing is aligned with all support clamps and end fittings and is not drawn, pulled, or otherwise forced into place by them. Never install a straight length of tubing between two rigidly-mounted fittings. Always incorporate at least one bend between such fittings to absorb strain caused by vibration and temperature changes.

Bond metallic fuel lines at each point where they are clamped to the structure. Integrally bonded and cushioned line support clamps are preferred to other clamping and bonding methods. To prevent possible failure, all fittings heavy enough to cause the line to sag should be supported by means other than the tubing. Place support clamps or brackets for metallic lines as follows close to bends as possible to reduce overhang as shown in *Figure 19-5*.

## HYDRAULIC LINES

Hydraulic lines and fitting have general requirements that apply to installation and inspection. Carefully inspect all lines and fittings at regular intervals to ensure airworthiness. Investigate any evidence of fluid loss or leaks. Check metal lines for leaks, loose anchorage, scratches, kinks, or other damage. Inspect fittings and connections for leakage, looseness, cracks, burrs, or other damage. Replace or repair defective elements. Make sure the lines and hoses do not chafe against one another and are correctly secured and clamped.

Tube O.D.	Approximate Distance Between Supports
1/8" - 3/16"	9"
1/4" - 5/16"	12"
3/8" - 1/2"	16"
5/8" - 3/4"	22"
1" - 1 1/4"	30"
1 1/2" - 2"	40"

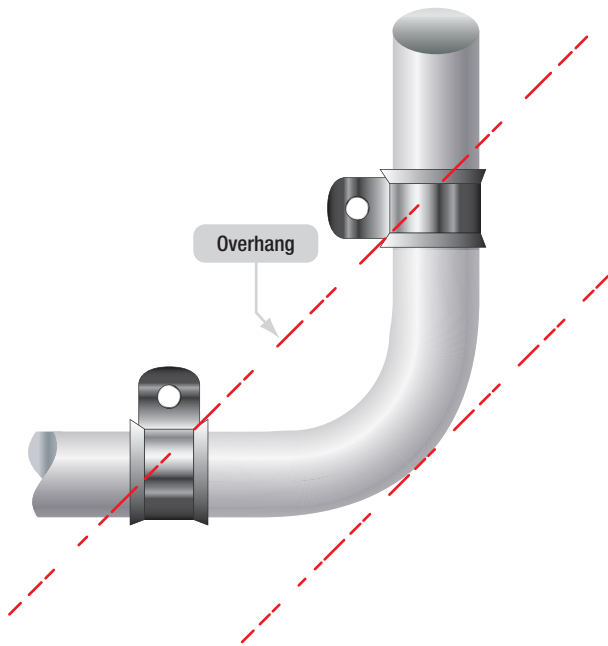

Figure 19-5. Location of clamps at tubing bends.

When inspection shows a line to be damaged or defective, replace the entire line or, if the damaged section is localized, a repair section may be inserted. In replacing lines, always use tubing of the same size and material as the original line. Use the old tubing as a template in bending the new line, unless it is too greatly damaged, in which case a template can be made from soft iron wire. Soft aluminum tubing (1100, 3003, or 5052) under 3/8-inch outside diameter may be bent by hand. For all other tubing use an acceptable hand or power tube-bending tool. Bend tubing carefully to avoid excessive flattening, kinking, or wrinkling. Minimum bend radii values are shown in *Figure 19-6*.

A small amount of flattening in bends is acceptable, but do not exceed 75 percent of the original outside diameter. Excessive flattening will cause fatigue failure of the tube. When installing the replacement tubing, line it up correctly with the mating part so that it is not forced into alignment by tightening of the coupling nuts.

Minor dents and scratches in tubing may be repaired. Scratches or nicks not deeper than 10 percent of the wall thickness in aluminum alloy tubing that are not in the heel of a bend may be repaired by burnishing with hand tools. Replace lines with severe die marks, seams, or splits in the tube. Any crack or deformity in a flare is unacceptable and cause for rejection. A dent less than 20 percent of the tube diameter is not objectionable unless it is in the heel of a bend. A severely-damaged line should be replaced; however, it may be repaired by cutting out the damaged section and inserting a tube

WRENCH TORQUE FOR TIGHTENING AN-818 NUT (pound inch)

Dash Nos. Reference	Tubing OD inches	ALUMINUM-ALLOY TUBING		STEEL TUBING		ALUMINUM-ALLOY TUBING (FLARE MS33583) FOR USE ON OXYGEN LINES ONLY		MINIMUM BEND RADIi MEASURED TO TUBING CENTERLINE. DIMENSION IN INCHES	
		Minimum	Maximum	Minimum	Maximum	Minimum	Maximum	Alum. Alloy	Steel
-2	1/8	20	30	75	85	--	--	3/8	--
-3	3/16	25	35	95	105	--	--	7/16	21/32
-4	1/4	50	65	135	150	--	--	9/16	7/8
-5	5/16	70	90	170	200	100	125	3/4	1-1/8
-6	3/8	110	130	270	300	200	250	15/16	1-5/16
-8	1/2	230	260	450	500	300	400	1-1/4	1-3/4
-10	5/8	330	360	650	700	--	--	1-1/2	2-3/16
-12	3/4	460	500	900	1000	--	--	1-3/4	2-5/8
-16	1	500	700	1200	1400	--	--	3	3-1/2
-20	1-1/4	800	900	1520	1680	--	--	3-3/4	4-3/8
-24	1-1/2	800	900	1900	2100	--	--	5	5-1/4
-28	1-3/4	--	--	--	--	--	--	--	--
-32	2	1800	2000	2660	2940	--	--	8	7

Figure 19-6. Tubing maintenance data.

section of the same size and material. Flare both ends of the undamaged and replacement tube sections and make the connection by using standard unions, sleeves, and tube nuts. If the damaged portion is short enough, omit the insert tube and repair by using one union and two sets of connection fittings.

When replacement of a flexible line is necessary, use the same type, size, part number, and length of hose as the line to be replaced. If the replacement of a hose with a swaged end type fitting is necessary, obtain a new hose assembly of the correct size and composition. Certain synthetic oils require a specially compounded synthetic rubber hose, which is compatible. Refer to the aircraft manufacturer's service information for the correct part number for the replacement hose. If the fittings on each end are of the correct type or sleeve type, a replacement may be fabricated as shown in *Figure 19-7*.

Before cutting new flexible wire braided hose to the proper size, tape the hose tightly with masking tape and cut in the center of the masking tape to prevent fraying. The use of a mandrel will prevent cutting the inside of the hose when inserting the fittings. Typical aircraft hose specifications and their uses are shown in *Figure 19-8*. Install hose assemblies without twisting as shown in *Figure 19-9*.

A hose should not be stretched tight between two fittings as this will result in overstressing and eventual failure. The length of hose should be sufficient to provide about 5 to 8 percent slack. Avoid tight bends in flex lines as they may result in failure. Never exceed the minimum bend radii as indicated in *Figure 19-10*.

Teflon hose is used in many aircraft systems because it has superior qualities for certain applications. Teflon is compounded from tetrafluoroethylene resin which is unaffected by fluids normally used in aircraft. It has an operating range of -65 °F to 450 °F. For these reasons, Teflon is used in hydraulic and engine lubricating systems where temperatures and pressures preclude the use of rubber hose. Although Teflon hose has excellent performance qualities, it also has peculiar characteristics that require extra care in handling. It tends to assume a permanent set when exposed to high pressure or temperature. Do not attempt to straighten a hose that has been in service.

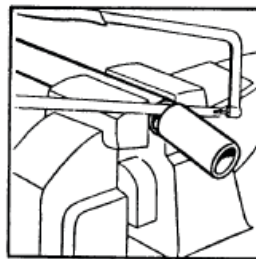

1. Place hose in vise and cut to desired length using fine tooth hacksaw or cut off wheel.

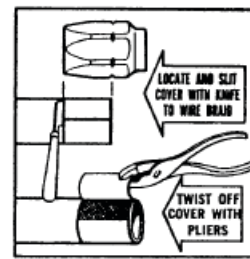

2. Locate length of hose to be cut off and slit cover with knife to wire braid. After slitting cover, twist off with pair of pliers. (see note below)

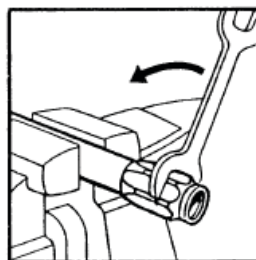

3. Place hose in vise and screw socket on hose counterclockwise.

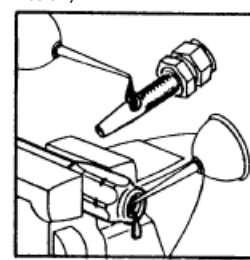

4. \*Lubricate inside of hose and nipple threads liberally.

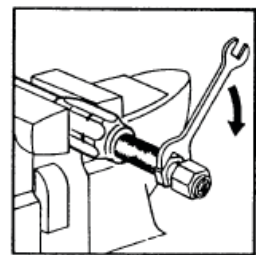

5. Screw nipple into socket using wrench on hex of nipple and leave .005 inches to .031 inches clearance between nipple hex and socket.

NOTE:  
Hose assemblies fabricated per MIL-H-8790 must have the exposed wire braid coated with a special sealant.

NOTE:  
Step 2 applies to high pressure hose only.

\*CAUTION:  
Do not use any petroleum product with hose designed for synthetic fluids, "SKYDROL and/or HYJET product." For a lubricant during assembly use a vegetable soap liquid.

Figure 19-7. Hose assembly instructions (can be used for low pressure hydraulic fluid, and oil line applications).

Any excessive bending or twisting may cause kinking or weakening of the tubing wall. Replace any hose that shows signs of leakage, abrasion, or kinking. Any hose suspected of kinking may be checked with a steel ball of proper size. *Figure 19-11* shows hose and ball sizes. The ball will not pass through if the hose is distorted beyond limits.

If the hose fittings are of the reusable type, a replacement hose may be fabricated as described in *Figure 19-7*. Refer to *Figure 19-10* for minimum bend radii. When a hose assembly is removed, the ends should be tied as shown in *Figure 19-12*, so that the preformed shape will be maintained. Refer to *Figure 19-13* for minimum bend radii for teflon hose.

**SINGLE WIRE BRAID FABRIC COVERED**

MIL PART NO.	TUBE SIZE O.D.	HOSE SIZE I.D.	HOSE SIZE O.D.	RECOMM. OPERATING PRESSURE	MINIMUM BURST PRESSURE	MAX PROOF PRESSURE	MINIMUM BEND RADIUS
MIL-H-8794- 3-L	3/16	1/8	0.45	3 000	12 000	6 000	3.00
MIL-H-8794- 4-L	1/4	3/16	0.52	3 000	12 000	6 000	3.00
MIL-H-8794- 5-L	5/16	1/4	0.58	3 000	10 000	5 000	3.38
MIL-H-8794- 6-L	3/8	5/16	0.67	2 000	9 000	4 500	4.00
MIL-H-8794- 8-L	1/2	13/32	0.77	2 000	8 000	4 000	4.63
MIL-H-8794-10-L	5/8	1/2	0.92	1 750	7 000	3 500	5.50
MIL-H-8794-12-L	3/4	5/8	1.08	1 750	6 000	3 000	6.50
MIL-H-8794-16-L	1	7/8	1.23	800	3 200	1 600	7.38
MIL-H-8794-20-L	1-1/4	1-1/8	1.50	600	2 500	1 250	9.00
MIL-H-8794-24-L	1-1/2	1-3/8	1.75	500	2 000	1 000	11.00
MIL-H-8794-32-L	2	1-3/16	2.22	350	1 400	700	13.25
MIL-H-8794-40-L	2-1/2	2-3/8	2.88	200	1 000	300	24.00
MIL-H-8794-48-L	3	3	3.56	200	800	300	33.00

**CONSTRUCTION:**  
Seamless synthetic rubber inner tube reinforced with one fiber braid one braid of high tensile steel wire and covered with an oil resistant rubber impregnated fiber

**IDENTIFICATION:**  
Hose is identified by specification number size number quarter year and year hose manufacturer's identifica-

**USES:**  
Hose is approved for use in aircraft hydraulic pneumatic coolant fuel and oil systems.

**OPERATING TEMPERATURES:**  
Sizes 3 through 12: Minus 65 °F. to plus 250 °F.

Sizes 16 through 48: Minus 40 °F. to plus 275 °F.

**NOTE:**  
Maximum temperatures and pressures should not be used simultaneously.

**MULTIPLE WIRE BRAID RUBBER COVERED**

MIL PART NO.	TUBE SIZE O.D.	HOSE SIZE I.D.	HOSE SIZE O.D.	RECOMM. OPERATING PRESSURE	MINIMUM BURST PRESSURE	MINIMUM PROOF PRESSURE	MINIMUM BEND RADIUS
MIL-H-8788- 4-L	1/4	7/32	0.63	3 000	16 000	8 000	3.00
MIL-H-8788- 5-L	5/16	9/32	0.70	3 000	14 000	7 000	3.38
MIL-H-8788- 6-L	3/8	11/32	0.77	3 000	14 000	7 000	5.00
MIL-H-8788- 8-L	1/2	7/16	0.86	3 000	14 000	7 500	5.75
MIL-H-8788-10-L	5/8	9/16	1.03	3 000	12 000	6 000	6.50
MIL-H-8788-12-L	3/4	11/16	1.22	3 000	12 000	6 500	7.75
MIL-H-8788-16-L	1	7/8	1.50	3 000	10 000	5 000	9.63

**HOSE CONSTRUCTION:**  
Seamless synthetic rubber inner tube reinforced with one fiber braid two or more steel wire braids and covered with synthetic rubber cover (for gas applications request perforated cover.

**IDENTIFICATION:**  
Hose is identified by specification number size number quarter year and year hose manufacturer's identification.

**USES:**  
High pressure hydraulic pneumatic coolant fuel and oil.

**OPERATING TEMPERATURES:**  
Minus 65 °F. to plus 200 °F.

Figure 19-8. Aircraft hose specifications.

All flexible hose installations should be supported at least every 24 inches. Closer supports are preferred. They should be carefully routed and securely clamped to avoid abrasion, kinking, or excessive flexing. Excessive flexing may cause weakening of the hose or loosening at the fittings.

RIGHT WAY



WRONG WAY



Do not bend or twist the hose as illustrated.

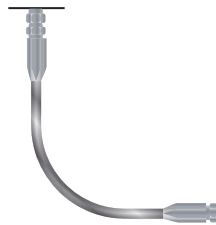

Allow enough slack in the hose line to provide for changes in length when pressure is applied. The hose will change in length from +2% to -4%.

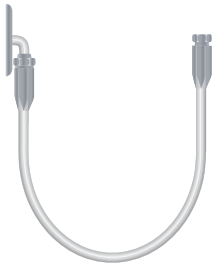

The use of elbows and adapters will ensure easier installation and in many installations will remove the strain from the hose line and greatly increase service life.

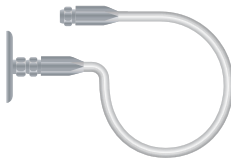

At all times keep the minimum bend radii of the hose as large as possible to avoid tube collapsing.

Figure 19-9. Proper hose installation.

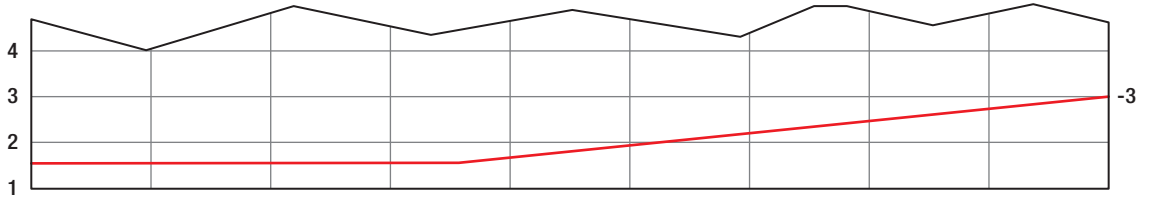

Inside Bend Radii vs Operating Pressure MIL-H-8794 Hose with No Flexing

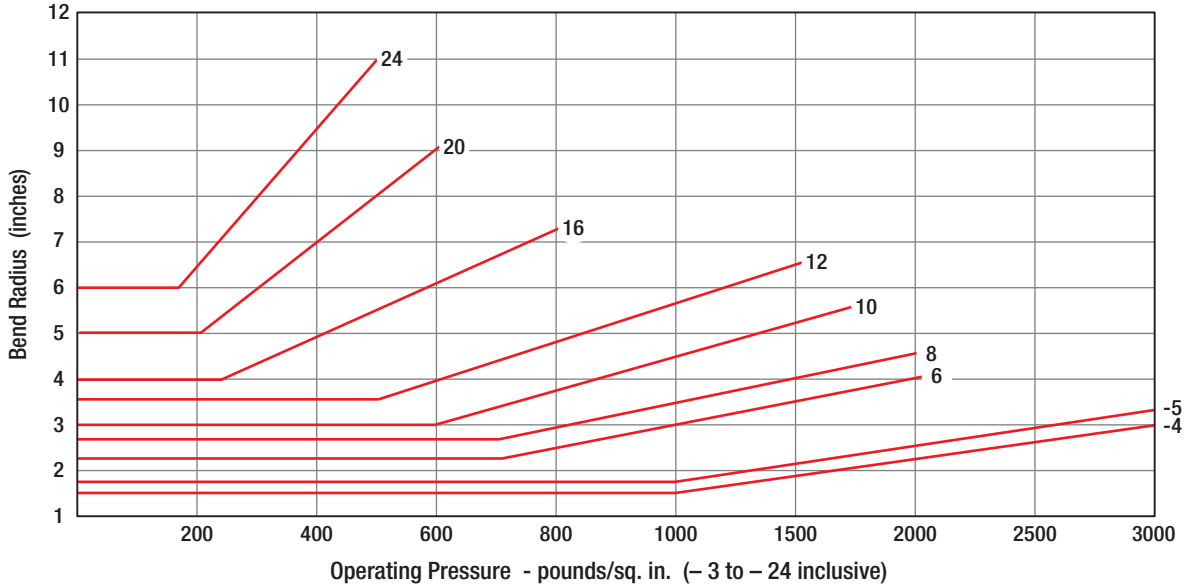

Minimum Bend Radii for -32, -40, and -48 at all pressures are as follows:

- 32 13.25'
- 40 24'
- 48 33'

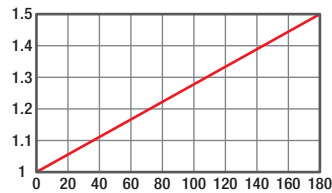

Total Flexing Range of Installed Hose (Degrees)

MIL-H-8788 HOSE WITH NO FLEXING	
4	3,000
5	3,375
6	5,000
8	5,750
10	6,500
12	7,750
16	9,625

Minimum Bend Radii of Hose Under Flexing Conditions = "N" x No Flexing Bend Radius of Either MIL-H-8797 or MIL-H-8788 Hose.

EXAMPLE:

For MIL-H-8794 hose, -12 size at 1,500 psi and having a flexing range of 60° minimum bend radius = 1.16 x 6.5 = 7 1/2 inches. (Measured at inside of bend.)

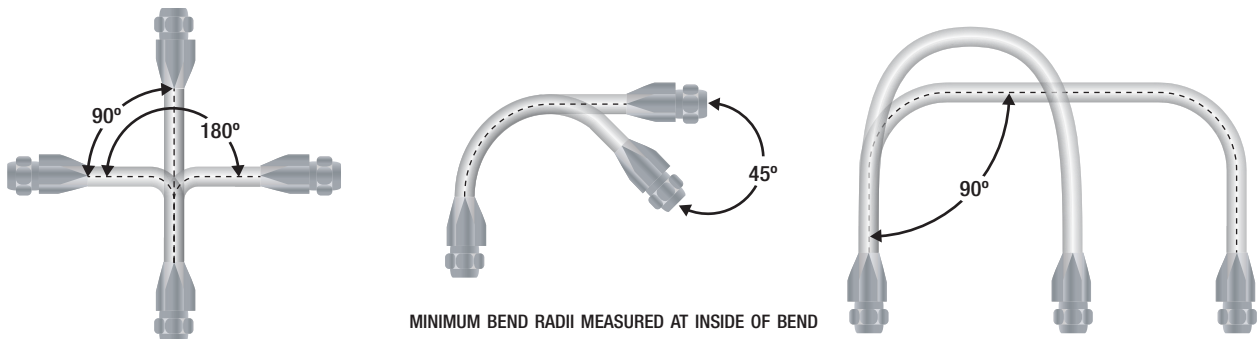

Figure 19-10. Minimum bend radii.

POWERPLANT INSTALLATION

Hole Size	Ball Size
-4	5/64
-5	9/64
-6	13/64
-8	9/32
-10	3/8
-12	1/2
-16	47/64
-20	61/64

Figure 19-11. Ball diameters for testing hose restrictions or kinking.

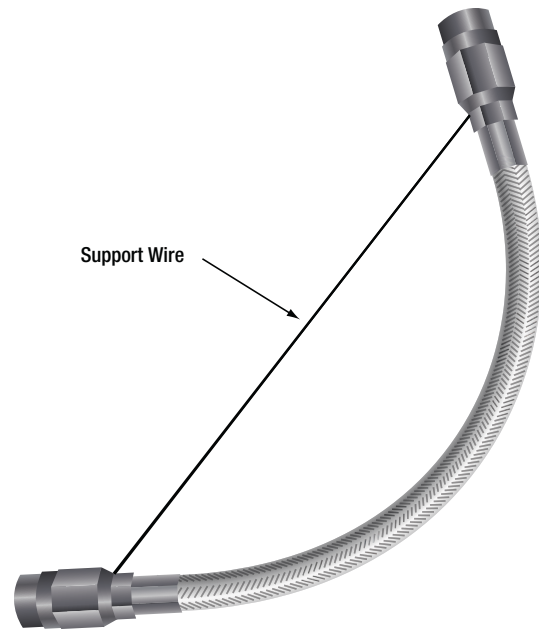

Figure 19-12. Suggested handling of preformed hose.

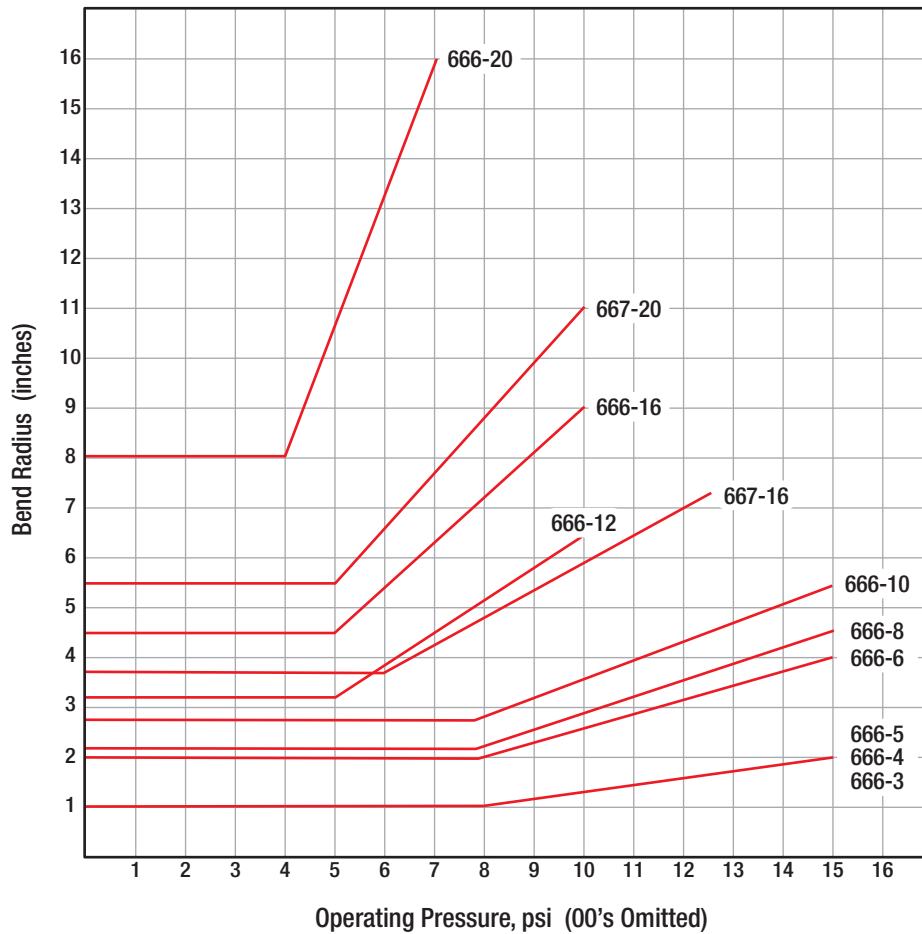

Figure 19-13. Minimum bend radii-Teflon hose.

## O-RING SEALS

An understanding of O-ring seal applications is necessary to determine when replacement should be made. The simplest application is where the O-ring merely serves as a gasket when it is compressed within a recessed area by applying pressure with a packing nut or screw cap. Leakage is not normally acceptable in this type of installation. In other installations, the O-ring seals depend primarily upon their resiliency to accomplish their sealing action. When moving parts are involved, minor seepage may be normal and acceptable. A moist surface found on moving parts of hydraulic units is an indication the seal is being properly lubricated. In pneumatic systems, seal lubrication is provided by the installation of a grease impregnated felt wiper ring. When systems are static, seepage past the seals is not normally acceptable.

Store O-ring seals where temperatures do not exceed 120° F. Keep seals packaged to avoid exposure to ambient air and light, particularly sunlight. During inspection, consider the following to determine whether seal replacement is necessary:

1. How much fluid is permitted to seep past the seals?  
In some installations minor seepage is normal. Refer to the manufacturer's maintenance information.
2. What effect does the leak have on the operation of the system? Know the system.
3. Does the leak of fluid create a hazard or affect surrounding installations? A check of the system fluid and acknowledge of previous fluid replenishment is helpful.
4. Will the system function safely without depleting the reservoirs until the next inspection?

Below are a few do's and don'ts that apply to o-ring seals:

- a. Correct all leaks from static seal installations.
- b. Don't retighten packing gland nuts; retightening will, in most cases, increase rather than decrease the leak.

- c. Never reuse o-ring seals because they tend to swell from exposure to fluids, and become set from being under pressure. They may have minor cuts or abrasions that are not readily discernible by visual inspection.
- d. Avoid using tools that might damage the seal or the sealing surface.
- e. Do not depend upon color-coding. Coding may vary with manufacturer
- f. Be sure that part number is correct
- g. Retain replacement seals in their package until ready for use. This provides proper identification and protects the seal from damage and contamination.
- h. Assure that the sealing surfaces are clean and free of nicks or scratches before installing seal.
- i. Protect the seal from any sharp surfaces that it may pass over during installation. Use an installation bullet or cover the sharp surfaces with tape.
- j. Lubricate the seal so it will slide into place smoothly.
- k. Be sure the seal has not twisted during installation.

When a flexible hose has been repaired or overhauled using existing hardware and new hose material, before the hose is installed on the aircraft it is recommended that the hose is tested to at least 1.5 system pressure. A new hose can be operationally checked after it is installed in the aircraft using system pressure.

Hydraulic components such as pumps, actuating cylinders, selector valves, relief valves, etc., should be repaired or adjusted following the airplane and component manufacturer's instructions. Inspect hydraulic filter elements at frequent intervals and replace as necessary.

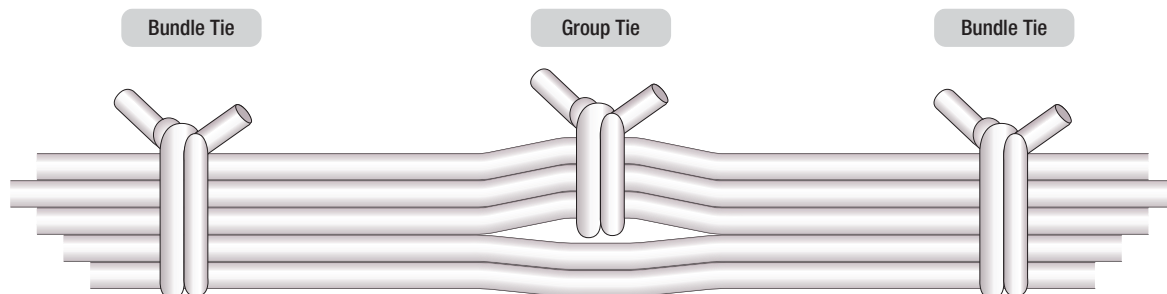

Figure 19-14. Group and bundle ties.



## FEEDERS, CONNECTORS AND WIRING LOOMS

Wire bundles must be routed in accessible areas that are protected from damage from personnel, cargo, and maintenance activity. They should not be routed in areas in where they are likely to be used as handholds or as support for personal equipment or where they could become damaged during removal of aircraft equipment. Wiring must be clamped so that contact with equipment and structure is avoided. Where this cannot be accomplished, extra protection, in the form of grommets, chafe strips, etc., should be provided. Protective grommets must be used, wherever wires cannot be clamped, in a way that ensures at least a 3/8-inch clearance from structure at penetrations.

Wire must not have a preload against the corners or edges of chafing strips or grommets. Wiring must be routed away from high-temperature equipment and lines to prevent deterioration of insulation. Protective flexible conduits should be made of a material and design that eliminates the potential of chafing between their internal wiring and the conduit internal walls. Wiring that must be routed across hinged panels, must be routed

and clamped so that the bundle will twist, rather than bend, when the panel is moved.

A wire bundle consists of a quantity of wires fastened or secured together and all traveling in the same direction. Wire bundles may consist of two or more groups of wires. It is often advantageous to have a number of wire groups individually tied within the wire bundle for ease of identification at a later date. (Figure 19-14)

Comb the wire groups and bundles so that the wires will lie parallel to each other and minimize the possibility of insulation abrasion. A combing tool, similar to that shown in Figure 19-15, may be made from any suitable insulating material, taking care to ensure all edges are rounded to protect the wire insulation.

The minimum radii for bends in wire groups or bundles must not be less than 10 times the outside diameter of their largest wire. They may be bent at six times their outside diameters at breakouts or six times the diameter where they must reverse direction in a bundle, provided that they are suitably supported. RF cables should not bend on a radius of less than six times the outside diameter of the cable. Care should be taken to avoid



Figure 19-15. Comb for straightening wires in bundles.

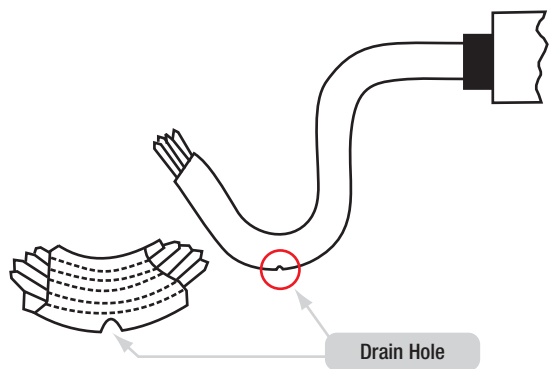

Drainage hole 1/8 inch diameter at lowest point in tubing. Make the hole after installation is complete and lowest point is firmly established.

Figure 19-17. Drainage hole in low point of tubing.

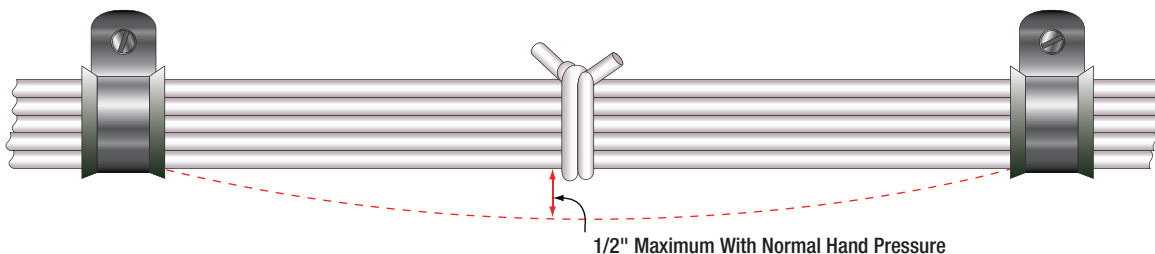

Figure 19-16. Slack between supports.

sharp bends in wires that have been marked with the hot stamping process.

Wiring should be installed with sufficient slack so that bundles and individual wires are not under tension. Wires connected to movable or shock-mounted equipment should have sufficient length to allow full travel without tension on the bundle. Wiring at terminal lugs or connectors should have sufficient slack to allow two re-terminations without replacement of wires. This slack should be in addition to the drip loop and the allowance for movable equipment.

Normally, wire groups or bundles should not exceed 1/2-inch deflection between support points, as shown in *Figure 19-16*.

This measurement may be exceeded provided there is no possibility of the wire group or bundle touching a surface that may cause abrasion. Sufficient slack should be provided at each end to:

- a. Permit replacement of terminals.
- b. Prevent mechanical strain on wires.
- c. Permit shifting of equipment for maintenance purposes.

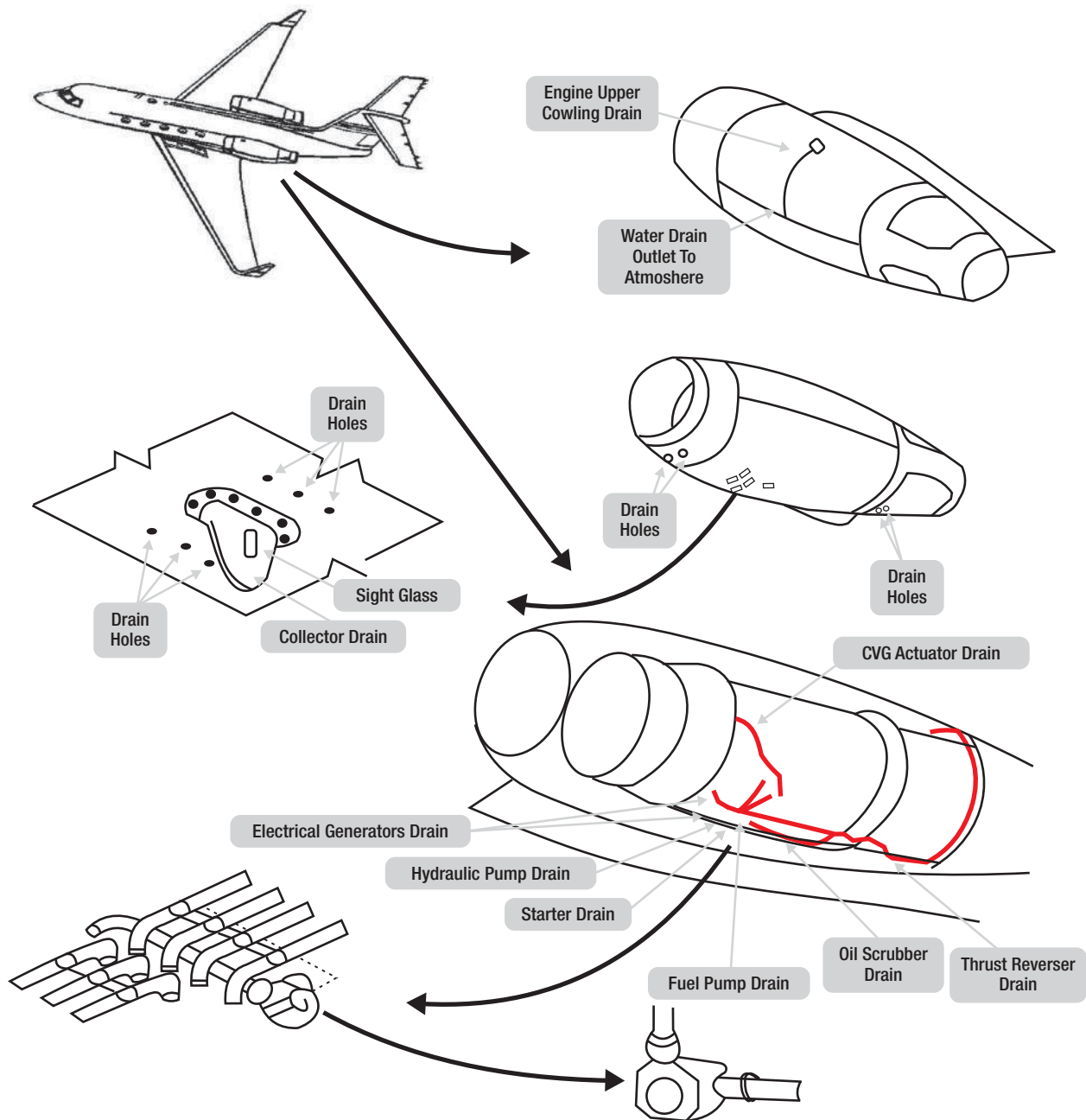

Figure 19-18. Typical drainage points on a turbine powerplant installation.

A drip loop is an area where wire is dressed downward to a connector, terminal block, panel, or junction box. In addition to the service termination and strain relief, a trap or drip loop shall be provided in the wiring to prevent fluid or condensate from running into the above devices. (*Figure 19-17*)

Wires or groups of wires should enter a junction box or piece of equipment in an upward direction where practicable. Where wires must be routed downwards to a junction box or unit of electric equipment, the entry should be sealed or adequate slack should be provided to form a trap or drip loop to prevent liquid from running down the wires in the box or electric unit. The power feeder wires should be routed so that they can be easily inspected or replaced. They must be given special protection to prevent potential chafing against other wiring, aircraft structure, or components.

Electrical connectors are covered in *Module 06 - Aircraft Materials and Hardware*. Refer to this module for information applicable to connectors used in powerplant installations.

## **DRAINS**

Powerplant installations make provisions to drain various fluids from the powerplant. Some provisions for drainage are for when a malfunction occurs but others are designed into the normal operation of the engine. Drains may flow overboard or to a reservoir collection point. Inspection of drains to ensure they are open and clear of debris is important. *Figure 19-18* illustrates the drains on a typical powerplant.

## **LIFTING POINTS**

When removing and replacing turbine engines, only the manufacturer lifting points should be used to raise and lower the engine into position. These fittings are designed to safely lift the weight of the engine. Damage could result lifting from any other point or fitting on the engine. Consult the manufacturer's data to determine exactly which fittings on an engine are the lifting points.

**Question: 19-1**

A \_\_\_\_\_ is a partition between the engine powerplant installation and the aircraft.

**Question: 19- 5**

Any crack or deformity of the flare in metallic flared tubing is \_\_\_\_\_.

**Question: 19-2**

One method of suppressing the noise from the fan stage of a high by-pass ratio engine is to incorporate a \_\_\_\_\_ around the inside wall of the by-pass duct.

**Question: 19-6**

A hose \_\_\_\_\_ be stretched tight between two fittings as this will result in overstressing and eventual failure.

**Question: 19-3**

Turbine engine vibration isolation mounts consist of \_\_\_\_\_ permanently enclosed in a metal case.

**Question: 19-7**

O-ring seals

- A. can be reused if no damage is visible.
- B. can be reused if installed in a low pressure application.
- C. should never be reused.

**Question: 19-4**

Metallic fuel lines are \_\_\_\_\_ at each point they are clamped to the airframe structure.

**Question: 19-8**

Normally, wire groups or bundles should not exceed \_\_\_\_\_ deflection between support points.

## ANSWERS

*Answer:* 19-1  
firewall.

*Answer:* 19-5  
cause for rejection.

*Answer:* 19-2  
noise absorbent liner.

*Answer:* 19-6  
should not.

*Answer:* 19-3  
a resilient material.

*Answer:* 19-7  
Answer: C

*Answer:* 19-4  
bonded.

*Answer:* 19-8  
½-inch.



PART-66 SYLLABUS **LEVELS**  
 CERTIFICATION CATEGORY → **A1** **B1**

**Sub-Module 20**  
**FIRE PROTECTION SYSTEMS**  
 Knowledge Requirements

*15.20 - Fire Protection Systems*  
 Operation of detection and extinguishing systems.

CERTIFICATION CATEGORY →	A1	B1
	1	2

**Level 1**  
 A familiarization with the principal elements of the subject.

- Objectives:*
- (a) The applicant should be familiar with the basic elements of the subject.
  - (b) The applicant should be able to give a simple description of the whole subject, using common words and examples.
  - (c) The applicant should be able to use typical terms.

**Level 2**  
 A general knowledge of the theoretical and practical aspects of the subject and an ability to apply that knowledge.

- Objectives:*
- (a) The applicant should be able to understand the theoretical fundamentals of the subject.
  - (b) The applicant should be able to give a general description of the subject using, as appropriate, typical examples.
  - (c) The applicant should be able to use mathematical formula in conjunction with physical laws describing the subject.
  - (d) The applicant should be able to read and understand sketches, drawings and schematics describing the subject.
  - (e) The applicant should be able to apply his knowledge in a practical manner using detailed procedures.

---

## FIRE PROTECTION SYSTEMS

Because fire is one of the most dangerous threats to an aircraft, the potential fire zones of all multiengine aircraft currently produced are protected by a fixed fire protection system. A "fire zone" is an area or region of an aircraft designated by the manufacturer to require fire detection and/or fire extinguishing equipment and a high degree of inherent fire resistance. The term "fixed" describes a permanently installed system in contrast to any type of portable fire extinguishing equipment, such as a hand-held fire extinguisher. Multiengine turbine powered aircraft are required to have fire protection system as are all commuter and transport category aircraft. Auxiliary power unit compartments are also required to have fire protection.

Several general failures or hazards can result in overheat conditions or fires peculiar to turbine engine aircraft because of their operating characteristics. The two major types of turbine failure can be classified as:

1. Thermodynamic, or;
2. Mechanical.

Thermodynamic causes upset the proportion of air used to cool combustion temperatures to the levels that the turbine materials can tolerate. When the cooling cycle is upset, turbine blades can melt, causing a sudden loss of thrust. The rapid buildup of ice on inlet screens or inlet guide vanes can result in severe overheating, causing the turbine blades to melt or to be severed and thrown outward. Such failure can result in a severed tail cone and possible penetration of the aircraft structure, tanks, or equipment near the turbine wheel. In general, most thermodynamic failures are caused by ice, excess air bleed or leakage, or faulty controls that permit compressor stall or excess fuel.

Mechanical failures, such as fractured or thrown blades, can also lead to overheat conditions or fires. Thrown blades can puncture the tail cone, creating an overheat condition. Failure of forward stages of multi-stage turbines usually is much more severe. Penetration of the turbine case by failed blades is a possible fire hazard, as is the penetration of lines and components containing flammable fluids.

A high flow of fuel through an improperly adjusted fuel nozzle can cause burn-through of the tail cone in some

engines. Engine fires can be caused by burning fluid that occasionally runs out through the exhaust pipe.

### COMPONENTS

A complete fire protection system includes both a fire detection and a fire extinguishing system. To detect fires or overheat conditions, detectors are placed in the various zones to be monitored. Fires are detected in aircraft by using one or more of the following: overheat detectors, rate-of temperature- rise detectors, and flame detectors. In addition to these methods, other types of detectors are used in aircraft fire protection systems, but are not used to detect engine fires.

For example, smoke detectors are better suited to monitor areas such as baggage compartments or lavatories, where materials burn slowly or smolder. Other types of detectors in this category include carbon monoxide detectors.

Fire protection systems on current-production aircraft do not rely on observation by crew members as a primary method of fire detection. An ideal fire detector system includes as many of the following features as possible:

1. A system that does not cause false warnings under any flight or ground condition.
2. Rapid indication of a fire and accurate location of the fire.
3. Accurate indication that a fire is out.
4. Indication that a fire has reignited.
5. Continuous indication for duration of a fire.
6. Means for electrically testing the detector system from the aircraft cockpit.
7. Detectors that resist damage from exposure to oil, water, vibration, extreme temperatures, or handling.
8. Detectors that are light in weight and easily adaptable to any mounting position.
9. Detector circuitry that operates directly from the aircraft power system without inverters.
10. Minimum electrical current requirements when not indicating a fire.
11. Each detector system should turn on a cockpit light, indicating the location of the fire, and have an audible alarm system.
12. A separate detector system for each engine.

# ENGINE FIRE DETECTION SYSTEMS

Several different types of fire detection system are installed in aircraft to detect engine fires. Two common types used are spot detectors and continuously loop systems. Spot detector systems use individual sensors to monitor a fire zone. Examples of spot detector systems are the thermal switch system, the thermocouple system, the optical fire detection system, and the pneumatic-based thermal fire detection system. Continuous loop systems are typically installed on transport type aircraft and provide more complete fire detection coverage by using several loop type of sensors.

## THERMAL SWITCH SYSTEM

A number of detectors or sensing devices are available. Many older model aircraft still operating have some type of thermal switch or thermocouple system. A thermal switch system has one or more lights energized by the aircraft power system and thermal switches that control operation of the light(s). These thermal switches are heat-sensitive units that complete electrical circuits at a certain temperature. They are connected in parallel with each other, but in series with the indicator lights (*Figure 20-1*). If the temperature rises above a set value in a location where a thermal switch is positioned, the thermal switch closes, completing the light circuit to indicate a fire or overheat condition.

No set number of thermal switches is required; the exact number usually is determined by the aircraft manufacturer. On some installations, all the thermal detectors are connected to one light; others may have a separate thermal switch for each indicator light.

Some warning lights are push-to-test lights. The bulb is tested by pushing it in to check an auxiliary test circuit. The circuit shown in *Figure 20-1* includes a test relay. With the relay contact in the position shown, there are two possible paths for current flow from the switches to the light. This is an additional safety feature. Energizing the test relay completes a series circuit and checks all the wiring and the light bulb. Also included in the circuit shown in *Figure 20-1* is a dimming relay. By energizing the dimming relay, the circuit is altered to include a resistor in series with the light. In some installations, several circuits are wired through the dimming relay, and all the warning lights may be dimmed at the same time.

## THERMOCOUPLE SYSTEMS

The thermocouple fire warning system operates on an entirely different principle than the thermal switch system. A thermocouple depends on the rate of temperature rise and does not give a warning when an engine slowly overheats or a short circuit develops. The system consists of a relay box, warning lights, and thermocouples. The wiring system of these units may be divided into the following circuits: (1) the detector circuit, (2) the alarm circuit, and (3) the test circuit. Shown in *Figure 20-2*.

The relay box contains two relays, the sensitive relay and the slave relay, and the thermal test unit. Such a box may contain from one to eight identical circuits, depending on the number of potential fire zones. The relays control the warning lights. In turn, the thermocouples control the operation of the relays. The circuit consists of several thermocouples in series with each other and with the sensitive relay.

The thermocouple is constructed of two dissimilar metals, such as chromel and constantan. The point where

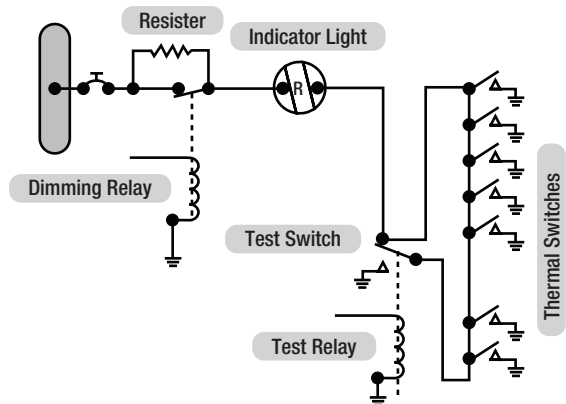

Figure 20-1. Thermal switch fire circuit.

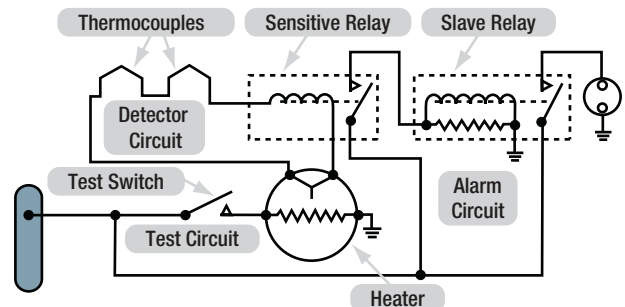

Figure 20-2. Thermocouple fire warning circuit.



these metals are joined and exposed to the heat of a fire is called a hot junction. There is also a reference junction enclosed in a dead air space between two insulation blocks. A metal cage surrounds the thermocouple to give mechanical protection without hindering the free movement of air to the hot junction.

If the temperature rises rapidly, the thermocouple produces a voltage because of the temperature difference between the reference junction and the hot junction. If both junctions are heated at the same rate, no voltage results. In the engine compartment, there is a normal, gradual rise in temperature from engine operation; because it is gradual, both junctions heat at the same rate and no warning signal is given. If there is a fire, however, the hot junction heats more rapidly than the reference junction. The ensuing voltage causes a current to flow within the detector circuit. Any time the current is greater than 4 milliamperes (0.004 ampere), the sensitive relay closes. This completes a circuit from the aircraft power system to the coil of the slave relay. The slave relay then closes and completes the circuit to the warning light to give a visual fire warning.

The total number of thermocouples used in individual detector circuits depends on the size of the fire zones and the total circuit resistance, which usually does not exceed 5 ohms. As shown in *Figure 20-2*, the circuit has two resistors. The resistor connected across the slave relay terminals absorbs the coil's self-induced voltage to prevent arcing across the points of the sensitive relay. The contacts of the sensitive relay are so fragile that they burn or weld if arcing is permitted.

When the sensitive relay opens, the circuit to the slave relay is interrupted and the magnetic field around its coil collapses. When this happens, the coil gets a voltage through self-induction, but with the resistor across the coil terminals, there is a path for any current flow as a result of this voltage. Thus, arcing at the sensitive relay contacts is eliminated.

## OPTICAL FIRE DETECTION SYSTEMS

Optical sensors, often referred to as "flame detectors," are designed to alarm when they detect the presence of prominent, specific radiation emissions from hydrocarbon flames. The two types of optical sensors available are infrared (IR) and ultraviolet, based on the specific emission wave lengths they are designed to detect.

## INFRARED OPTICAL FIRE PROTECTION

IR-based optical flame detectors are used primarily on light turboprop aircraft and helicopter engines. These sensors have proven to be very dependable and economical for the relatively benign environments of these applications.

### *Principle of Operation*

Radiation emitted by the fire crosses the airspace between the fire and the detector and impinges on the detector front face and window. The window allows a broad spectrum of radiation to pass into the detector where it impinges on the face of the sensing device filter. The filter allows only radiation in a tight waveband centered around 4.3 micrometers in the IR to pass on to the radiation-sensitive surface of the sensing device. The radiation striking the sensing device minutely raises its temperature causing small thermoelectric voltages to be generated. These voltages are fed to an amplifier whose output is connected to various analytical electronic processing circuits. The processing electronics is tailored exactly to the time signature of all known hydrocarbon flame sources and ignores false alarm sources, such as incandescent lights and sunlight. Alarm sensitivity level is accurately controlled by a digital circuit. A typical warning system is illustrated in *Figure 20-3*.

## PNEUMATIC THERMAL FIRE DETECTION

Pneumatic detectors are based on the principles of gas laws. The sensing element consists of a closed helium-filled tube connected at one end to a responder assembly. As the element is heated, the gas pressure inside the tube increases until the alarm threshold is reached. At this point, an internal switch closes and reports an alarm to the cockpit. The pneumatic detector integrity pressure switch opens and triggers the fault alarm if the pneumatic detector loses pressure, as in the case of a leak.

## CONTINUOUS-LOOP DETECTOR SYSTEMS

Large commercial aircraft almost exclusively use continuous thermal sensing elements for powerplant protection, since these systems offer superior detection performance and coverage, and they have the proven ruggedness to survive in the harsh environment of modern turbofan engines.

Functional Schematic

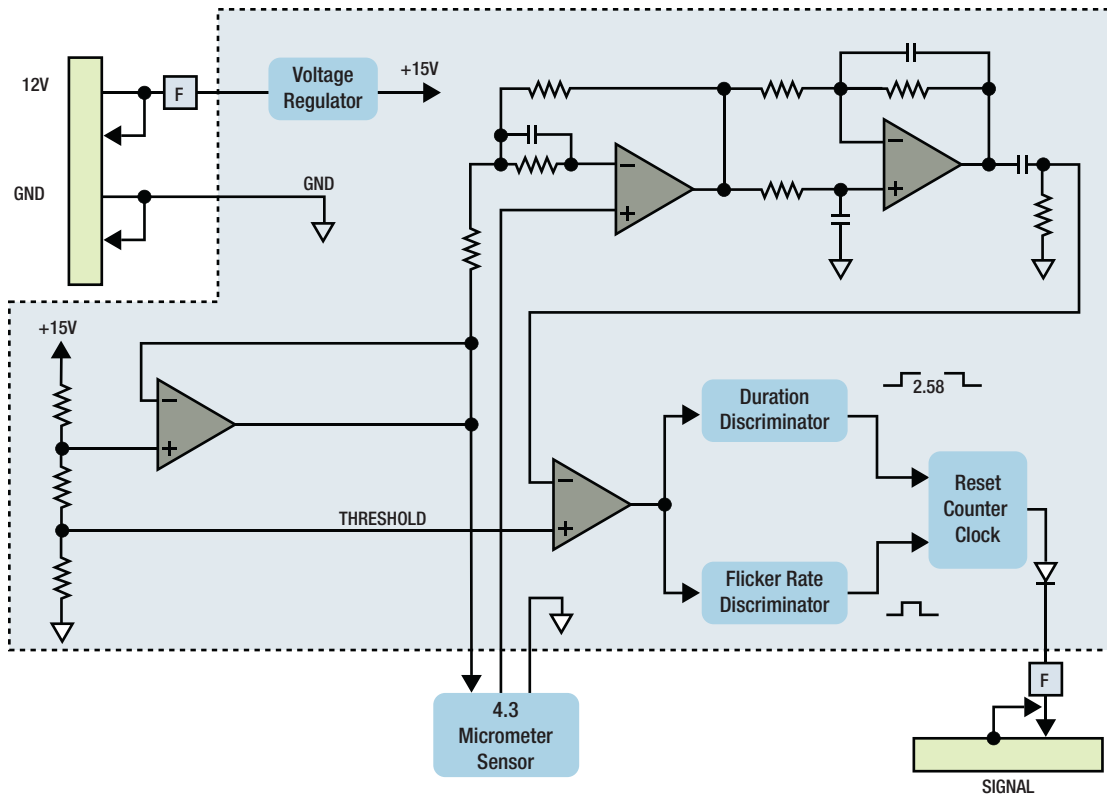

Figure 20-3. Optical fire detection system circuit.

A continuous-loop detector, or sensing system, permits more complete coverage of a fire hazard area than any of the spot-type temperature detectors. Continuous-loop systems are versions of the thermal switch system. They are overheat systems, heat-sensitive units that complete electrical circuits at a certain temperature. There is no rate-of-heat rise sensitivity in a continuous-loop system. Two widely used types of continuous-loop systems are the Kidde and the Fenwal systems. This text briefly discusses the Fenwal system, while the Kidde system is discussed more in-depth.

### FENWAL CONTINUOUS-LOOP SYSTEM

The Fenwal system uses a slender inconel tube packed with thermally sensitive eutectic salt and a nickel wire center conductor. (Figure 20-4) Lengths of these sensing elements are connected in series to a control unit. The elements may be of equal or varying length and of the same or different temperature settings. The control unit, operating directly from the power source, impresses a small voltage on the sensing elements. When an overheat condition occurs at any point along the element length, the resistance of the eutectic salt within the sensing element drops sharply, causing current to

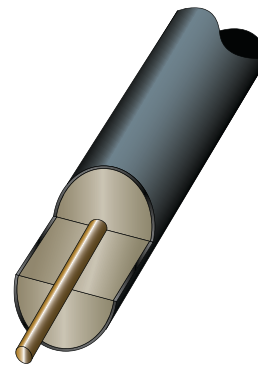

Figure 20-4. Fenwal sensing element.

flow between the outer sheath and the center conductor. This current flow is sensed by the control unit, which produces a signal to actuate the output relay.

When the fire has been extinguished or the critical temperature lowered, the Fenwal system automatically returns to standby alert, ready to detect any subsequent fire or overheat condition. The Fenwal system may be wired to employ a "loop" circuit. In this case, should an open circuit occur, the system still signals fire or overheat. If multiple open circuits occur, only that section between breaks becomes inoperative.

## KIDDE CONTINUOUS-LOOP SYSTEM

In the Kidde continuous-loop system, two wires are imbedded in an inconel tube filled with a thermistor core material. (*Figure 20-5*) Two electrical conductors go through the length of the core. One conductor has a ground connection to the tube and the other conductor connects to the fire detection control unit. As the temperature of the core increases, electrical resistance to ground decreases. The fire detection control unit monitors this resistance. If the resistance decreases to the overheat set point, an overheat indication occurs in the flight deck. Typically, a 10-second time delay is incorporated for the overheat indication. If the resistance decreases more to the fire set point, a fire warning occurs. When the fire or overheat condition is gone, the resistance of the core material increases to the reset point and the flight deck indications go away.

The rate of change of resistance identifies an electrical short or a fire. The resistance decreases more quickly with an electrical short than with a fire. In addition to fire and overheat detection, the Kidde continuous-loop system can supply nacelle temperature data to the airplane condition monitoring function of the Aircraft In-Flight Monitoring System (AIMS).

## SENSING ELEMENT

The sensing element consists, essentially, of an infinite number of unit thermistors electrically in parallel along its length. The resistance of the sensing element

is a function of the length heated, as well as the temperature-heating of less than the full length of element, which requires that portion to be heated to a higher temperature to achieve the same total resistance change. As a result, the system responds not to a fixed alarm temperature but to the sum of the resistances (in parallel) that reflects a non-arithmetic "average." The sensing element may be routed close to nonhazardous hot spots that may have a normal temperature well above the overall alarm) temperature, without danger of causing a false alarm. This feature permits the alarm point to be set close to the maximum general ambient temperature, giving greater sensitivity to a general overheat or fire without being subject to false alarms from localized nonhazardous hot spots.

## COMBINATION FIRE AND OVERHEAT WARNING

The analog signal from the thermistor sensing element permits the control circuits to be arranged to give a two level response from the same sensing element loop. The first is an overheat warning at a temperature level below the fire warning, indicating a general engine compartment temperature rise, which could be caused by leakage of hot bleed air or combustion gas into the engine compartment. It could be an early warning of fire, and would alert the crew to appropriate action to reduce the engine compartment temperature. The second-level response would be at a level above that attainable by the leaking hot gas and would be the fire warning.

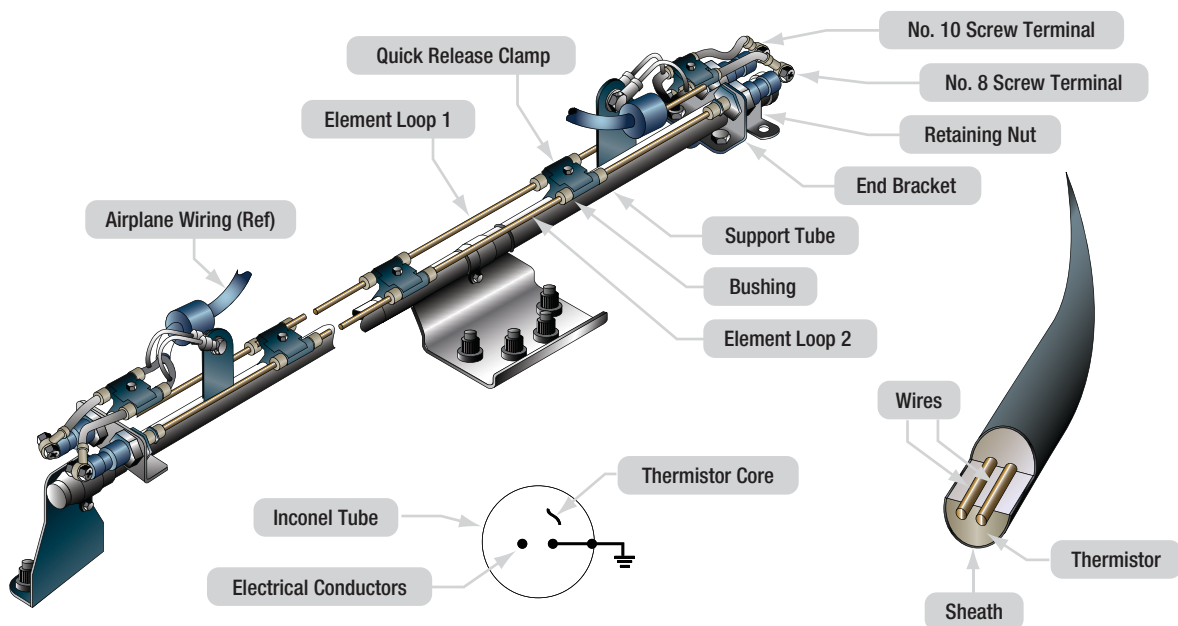

Figure 20-5. Kidde continuous-loop system.

## TEMPERATURE TREND INDICATION

The analog signal produced by the sensing element loop as its temperature changes can readily be converted to signals suitable for meter or cathode ray tube (CRT) display to indicate engine bay temperature increases from normal. A comparison of the readings from each loop system also provides a check on the condition of the fire detection system, because the two loops should normally read alike.

## SYSTEM TEST

The integrity of the continuous-loop fire detection system may be tested by actuating a test switch in the flight deck, which switches one end of the sensing element loop from its control circuit to a test circuit, built into the control unit, that simulates the sensing element resistance change due to fire. (*Figure 20-6*) If the sensing element loop is unbroken the resistance detected "seen" by the control circuit is now that of the simulated fire and so the alarm is signaled. This demonstrates, in addition to the continuity of the sensing element loop, the integrity of the alarm indicator circuit and the proper functioning of the control circuits. The thermistor properties of the sensing element remain unchanged for the life of the element (no chemical or physical changes take place on heating), so that it functions properly as long as it is electrically connected to the control unit. Fault Indication Provision can be made in the control unit to send a fault signal to activate a fault indicator whenever the short discriminator circuit detects a short in the sensing element loop. While this is a requirement in 14 CFR for transport category aircraft because such a short disables the fire detection system, it is offered as an option for other aircraft types in which it may not be a requirement.

## DUAL-LOOP SYSTEMS

Dual-loop systems are, in essence, two complete basic fire detection systems with their output signals connected so that both must signal to result in a fire warning. This arrangement, called "AND" logic, results in greatly increased reliability against false fire warnings from any cause. Should one of the two loops be found inoperative at the preflight integrity test, a cockpit selector switch disconnects that loop and allows the signal from the other loop alone to activate the fire warning. Since the single operative loop meets all fire detector requirements, the aircraft can be safely dispatched and maintenance deferred to a more

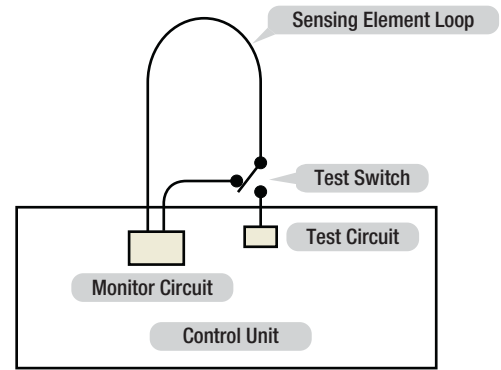

Figure 20-6. Continuous-loop fire detection system test circuit.

convenient time. However, should one of the two loops become inoperative in flight and a fire subsequently occur, the fire signaling loop activates a cockpit fault signal that alerts the flight crew to select single loop operation to confirm the possible occurrence of fire.

## AUTOMATIC SELF-INTERROGATION

Dual-loop systems automatically perform the loop switching and decision-making function required of the flight crew upon appearance of the fault indication in the cockpit. Automatic self-interrogation eliminates the fault indication, and assures the immediate appearance of the fire indication should fire occur while at least one loop of the dual-loop system is operative. Should the control circuit from a single loop signal "fire," the self-interrogation circuit automatically tests the functioning of the other loop. If it tests operative, the circuit suppresses the fire signal (because the operative loop would have signaled if a fire existed). If, however, the other loop tests inoperative, the circuit outputs a fire signal. The interrogation and decision takes place in milliseconds, so that no delay occurs if a fire actually exists.

## SUPPORT TUBE-MOUNTED SENSING ELEMENTS

When you want to mount the sensing elements on the engine, and in some cases, on the aircraft structure, the support tube mounted element solves the problem of providing sufficient element support points, and greatly facilitates the removal and reinstallation of the sensing elements for engine or system maintenance.

Most modern installations use the support tube concept of mounting sensing elements for better maintainability as well as increased reliability. The sensing element is attached to a prebent stainless steel

tube by closely spaced clamps and bushings, where it is supported from vibration damage and protected from pinching and excessive bending. The support tube-mounted elements can be furnished with either single- or dual-sensing elements.

Being prebent to the designed configuration assures its installation in the aircraft precisely in its designed location, where it has the necessary clearance to be free from the possibility of the elements chafing against

engine or aircraft structure. The assembly requires only a few attachment points, and removal for engine maintenance is quick and easy. Should the assembly require repair or maintenance, it is easily replaced with another assembly, leaving the repair for the shop. A damaged sensing element is easily replaced in the assembly. The assembly is rugged, easy to handle, and unlikely to suffer damage during handling for installation or removal.

## FIRE DETECTION CONTROL UNIT (FIRE DETECTION CARD)

The control unit for the simplest type of system typically contains the necessary electronic resistance monitoring and alarm output circuits, housed in a hermetically sealed aluminum case and fitted with a mounting bracket and circular electrical connector. For more sophisticated systems, control modules may be employed

that contain removable control cards having circuitry for individual hazard areas, and/or unique functions. In the most advanced applications, the detection system circuitry controls all aircraft fire protection functions, including fire detection and extinguishing for engines, APUs, cargo bays, and bleed air systems.

## FIRE ZONES

The powerplant installation has several designated fire zones: (1) the engine power section; (2) the engine accessory section; (3) except for reciprocating engines, any complete powerplant compartment in which no isolation is provided between the engine power section and the engine accessory section; (4) any APU compartment; (5) any fuel-burning heater and other combustion equipment installation; (6) the compressor and accessory sections of turbine engines; and (7) combustor, turbine, and tailpipe sections of turbine engine installations that contain lines or components carrying flammable fluids or gases.

*Figure 20-7* shows fire protection for a large turbo fan engine. In addition to the engine and nacelle area zones, other areas on multiengine aircraft are provided with fire detection and protection systems. These areas include baggage compartments, lavatories, APU, combustion heater installations, and other hazardous areas. Discussion of fire protection for these areas is not included in this section, which is limited to engine fire protection.

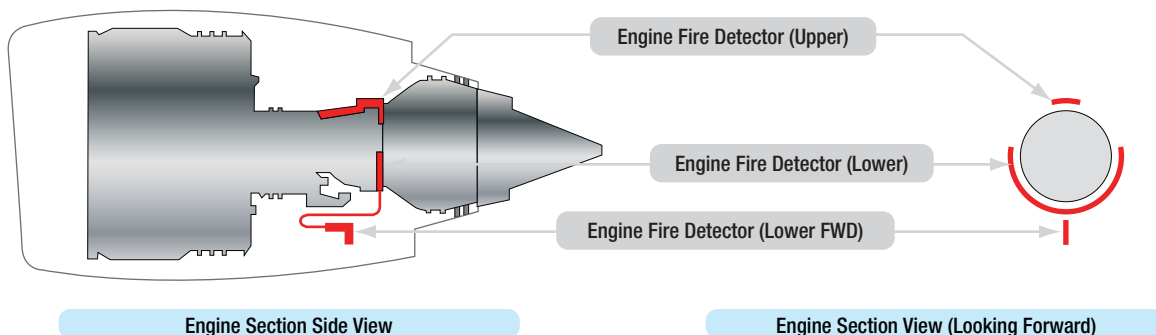

Figure 20-7. Large turbofan engine fire zones.

## ENGINE FIRE EXTINGUISHING SYSTEM

Commuter aircraft certificated under 14 CFR part 23 are required to have, at a minimum, a one-shot fire extinguishing system. All transport category aircraft certificated under 14 CFR part 25 are required to have two discharges, each of which produces adequate agent concentration. An individual one-shot system may be used for APUs, fuel burning heaters, and other combustion equipment. For each "other" designated fire zone, two discharges (two-shot system) must be provided, each of which produces adequate agent concentration. (Figure 20-8)

### FIRE EXTINGUISHING AGENTS

The fixed fire extinguisher systems used in most engine fire protection systems are designed to dilute the atmosphere with an inert agent that does not support combustion. Many systems use perforated tubing or discharge nozzles to distribute the extinguishing agent. High rate of discharge (HRD) systems use open end tubes to deliver a quantity of extinguishing agent in 1 to 2 seconds. The most common extinguishing agent still used today is Halon 1301 because of its effective firefighting capability and relatively low toxicity (U.L. classification Group 61). Noncorrosive, Halon 1301 does not affect the material it contacts and requires no clean-up when discharged. Halon 1301 is the current extinguishing agent for commercial aircraft, but a

replacement is under development. Because Halon 1301 depletes the ozone layer only recycled Halon 1301 is currently available. Halon 1301 is used until a suitable replacement is developed. Some military aircraft use HCL-125, which the Federal Aviation Administration (FAA) is testing for use in commercial aircraft.

### TURBINE ENGINE GROUND FIRE PROTECTION

On many aircraft, means are usually provided for rapid access to the compressor, tailpipe, or burner compartments. Many aircraft systems are equipped with spring loaded or pop-out access doors in the skin of the various compartments. Internal engine tailpipe fires that take place during engine shutdown or false starts can be blown out by motoring the engine with the starter. A running engine can be accelerated to rated speed to achieve the same result. If such a fire persists, a fire extinguishing agent can be directed into the tailpipe. It should be remembered that excessive use of CO<sub>2</sub>, or other agents that have a cooling effect, can shrink the turbine housing on the turbine and cause the engine to disintegrate.

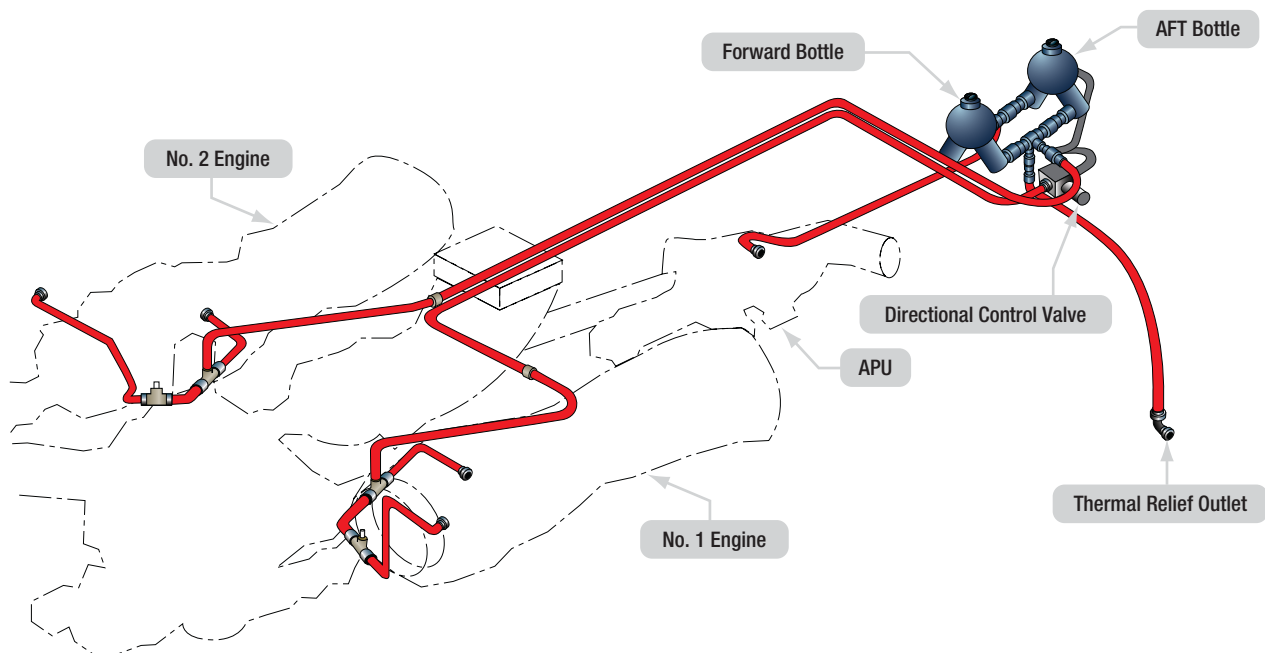

Figure 20-8. Typical fire extinguishing system.

## CONTAINERS

Fire extinguisher containers (HRD bottles) store a liquid halogenated extinguishing agent and pressurized gas (typically nitrogen) normally manufactured from stainless steel. Depending upon design considerations, alternate materials are available including titanium. Containers are also available in a wide range of capacities and are produced under Department of Transportation (DOT) specifications or exemptions. Most aircraft containers are spherical in design, which provides the lightest weight possible. However, cylindrical shapes are available where space limitations are a factor. Each container incorporates a temperature/pressure sensitive safety relief diaphragm that prevents container pressure from exceeding container test pressure in the event of exposure to excessive temperatures. (Figure 20-9)

### DISCHARGE VALVES

Discharge valves are installed on the containers. A cartridge (squib) and frangible disk type valve are installed in the outlet of the discharge valve

assembly. Special assemblies having solenoid-operated or manually-operated seat type valves are also available. Two types of cartridge disk-release techniques are used. Standard release type uses a slug driven by explosive energy to rupture a segmented closure disk.

For high temperature or hermetically sealed units, a direct explosive impact type cartridge is used, which applies fragmentation impact to rupture a pre-stressed corrosion resistant steel diaphragm. Most containers use conventional metallic gasket seals that facilitate refurbishment following discharge. (Figure 20-10)

### PRESSURE INDICATION

A wide range of diagnostics are utilized to verify the fire extinguisher agent charge status. A simple visually indicated gauge is available, typically a vibration-resistant helical bourdon-type indicator. (Figure 20-9)

A combination gauge switch visually indicates actual container pressure and also provides an electrical

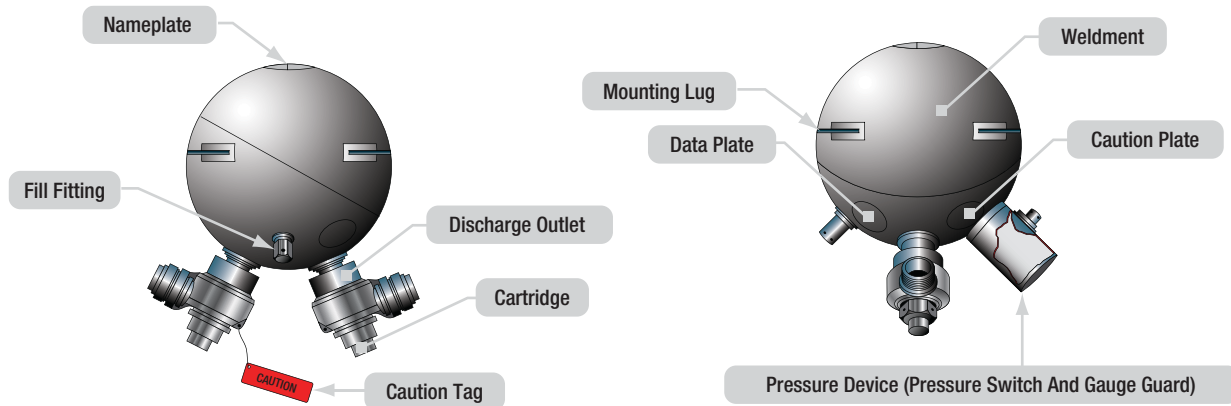

Figure 20-9. Fire extinguisher containers (HRD bottles).



Figure 20-10. Discharge valve and cartridge (squib).

signal if container pressure is lost, precluding the need for discharge indicators. A ground checkable diaphragm-type low-pressure switch is commonly used on hermetically sealed containers. The Kidde system also has a temperature compensated pressure switch that tracks the container pressure variations with temperatures by using a hermetically sealed reference chamber.

### TWO-WAY CHECK VALVE

A complete line of two-way check valves is available, manufactured from either lightweight aluminum or steel. These valves are required in a two-shot system to prevent the agent in a reserve container from backing up into the previous emptied main container. Valves are supplied with either MS-33514 or MS-33656 fitting configurations.

### DISCHARGE INDICATORS

Discharge indicators provide immediate visual evidence of container discharge on fire extinguishing systems. Two kinds of indicators can be furnished: thermal and discharge. Both types are designed for aircraft and skin mounting. (Figure 20-11)

#### THERMAL DISCHARGE INDICATOR (RED DISK)

The thermal discharge indicator is connected to the fire container relief fitting and ejects a red disk to show when container contents have dumped overboard due to excessive heat. The agent discharges through the opening created when the disk blows out. This gives the flight and maintenance crews an indication that the fire extinguisher container needs to be replaced before the next flight.

#### YELLOW DISK DISCHARGE INDICATOR

If the flight crew activates the fire extinguisher system, a yellow disk is ejected from the skin of the aircraft fuselage. This is an indication for the maintenance crew that the fire extinguishing system was activated by the flight crew, and that the fire extinguishing container needs to be replaced before the next flight.

### FIRE SWITCH

Fire switches are typically installed on the center overhead panel or center console in the flight deck. (Figure 20-12) When the fire switch is activated, the following happens: the engine stops because the fuel control shuts off, the engine is isolated from the aircraft

systems, and the fire extinguishing system is armed. Some aircraft use fire switches that need to be pulled and turned to activate the system, while others use a push-type switch with a guard. To prevent accidental activation of the fire switch, a lock is installed that releases the fire switch only when a fire has been detected. This lock can be manually released by being manually released by the flight crew if the fire detection system malfunctions. (Figure 20-13)



Figure 20-11. Discharge indicators.



Figure 20-12. Engine fire switches.



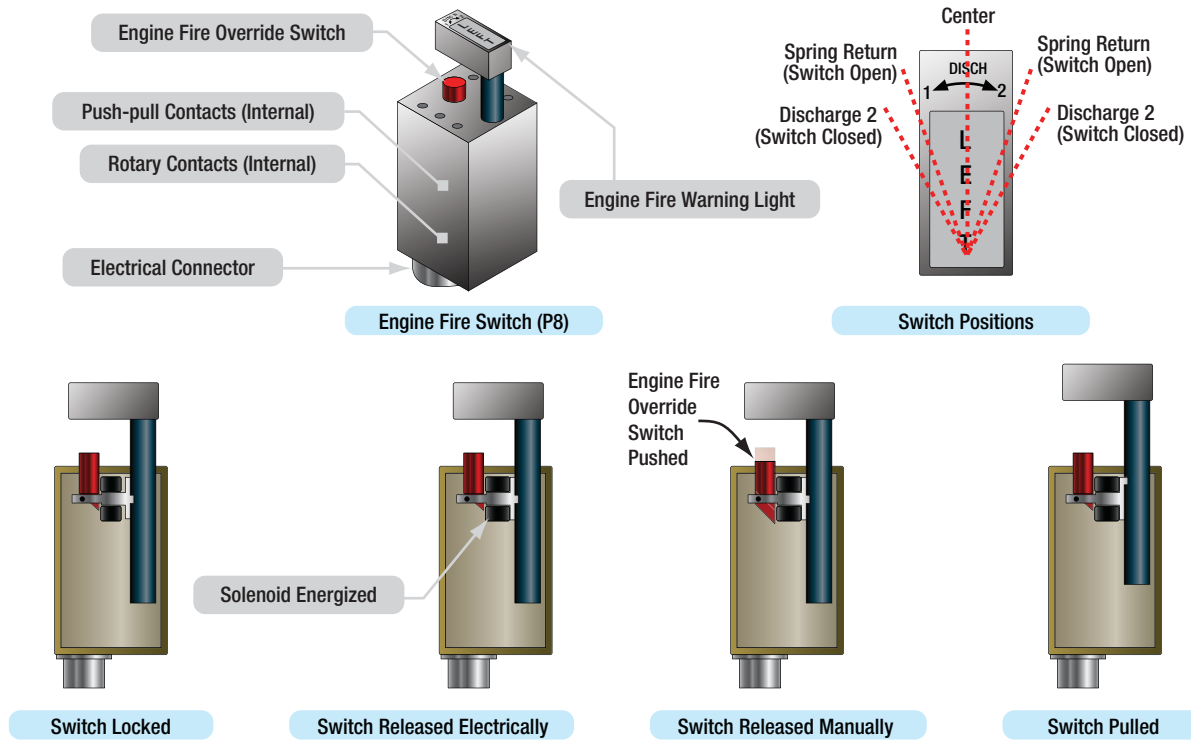

Figure 20-13. Engine fire switch operation.

## WARNING SYSTEMS

Visible and audible warning systems are installed in the cockpit to alert the flight crew. A horn sounds and one or

several warning lights illuminate to alert the flight crew that an engine fire has been detected. These indications stop when the fire is extinguished.

## BOEING 777 AIRCRAFT FIRE DETECTION AND EXTINGUISHING SYSTEM

The following section discusses the fire detection and extinguishing system of the B777 aircraft. The information is included only for familiarization purposes. Each engine has two fire detection loops: loop 1 and loop 2. A fire detection card in the system card file monitors the loops for fires, overheat conditions, and faults. There is a fire detection card for each engine.

### OVERHEAT DETECTION

If the fire detection loops detect an overheat condition, the fire detection card sends a signal to the AIMS and to the warning electronics unit. The following indications occur in the flight deck:

- The master caution lights come on.
- The caution aural operates.
- An engine overheat caution message shows.

### FIRE DETECTION

If an engine fire occurs, the fire detection card sends a signal to the AIMS and to the warning electronics unit,

and a warning message illuminates.

The following indications occur in the flight deck:

- The master warning lights come on.
- The fire warning aural operates.
- An engine fire warning message shows.
- The engine fire warning light comes on.
- The fuel control switch fire warning light comes on.

### NACELLE TEMPERATURE RECORDING

The fire detection card measures the average temperature of the loops. This data goes to the AIMS through the system's ARINC 629 buses and is recorded by the airplane condition monitoring function.

### CONTINUOUS FAULT MONITORING

The fire detection card monitors the two loops and their wiring for defects. In normal (dual loop) operation, both loops must have a fire or overheat condition to cause the flight deck indications. If a failure occurs

in a loop, the fire detection card sends the data to the AIMS. A status message shows, and the system changes to single-loop operation. In this mode, fire/overheat indications occur when one loop is defective and the other has a fire or overheat condition.

### SINGLE/DUAL LOOP OPERATION

The fire detection card monitors the loops for faults. In normal (dual loop) operation, both loops must have a fire or overheat condition to cause the flight deck indications. If one detection loop fails, the card sends data about the failure to the AIMS, and a status message shows. The card changes to single-loop operation, if necessary. If both detection loops fail, an advisory message and status messages is displayed, and the fire detection system does not operate.

### SYSTEM TEST

Built-in test equipment (BITE) performs a test of the engine fire detection system for these conditions:

- When the system first gets power
- After a power interrupt
- Every 5 minutes of operation

(Figures 20-14 and 20-15)

### FIRE EXTINGUISHER CONTAINERS

The B777 airplane has two fire extinguishing bottles that contain Halon fire extinguishing agent pressurized with nitrogen. The engine fire switches in the flight deck are pulled and rotated to release the Halon. Halon from each bottle can be discharged to the right or left engine. Engine indicating and crew alerting system (EICAS) messages, status messages, and indicator lights show when the bottle pressure is low. The two engine fire extinguishing bottles are located behind the right sidewall lining of the forward cargo compartment, aft of the cargo door. (Figure 20-16)

The two engine fire extinguishing bottles are identical. Each bottle has these following components:

- A safety relief and fill port
- A handle for removal and installation
- A pressure switch
- Two discharge assemblies
- An identification plate
- Four mounting lugs

(Figures 20-17, 20-18, 20-19)

The bottles contain Halon fire extinguishing agent pressurized with nitrogen. If the pressure in the bottle becomes too high, the safety relief and fill port opens so the bottle does not explode. The discharge assembly

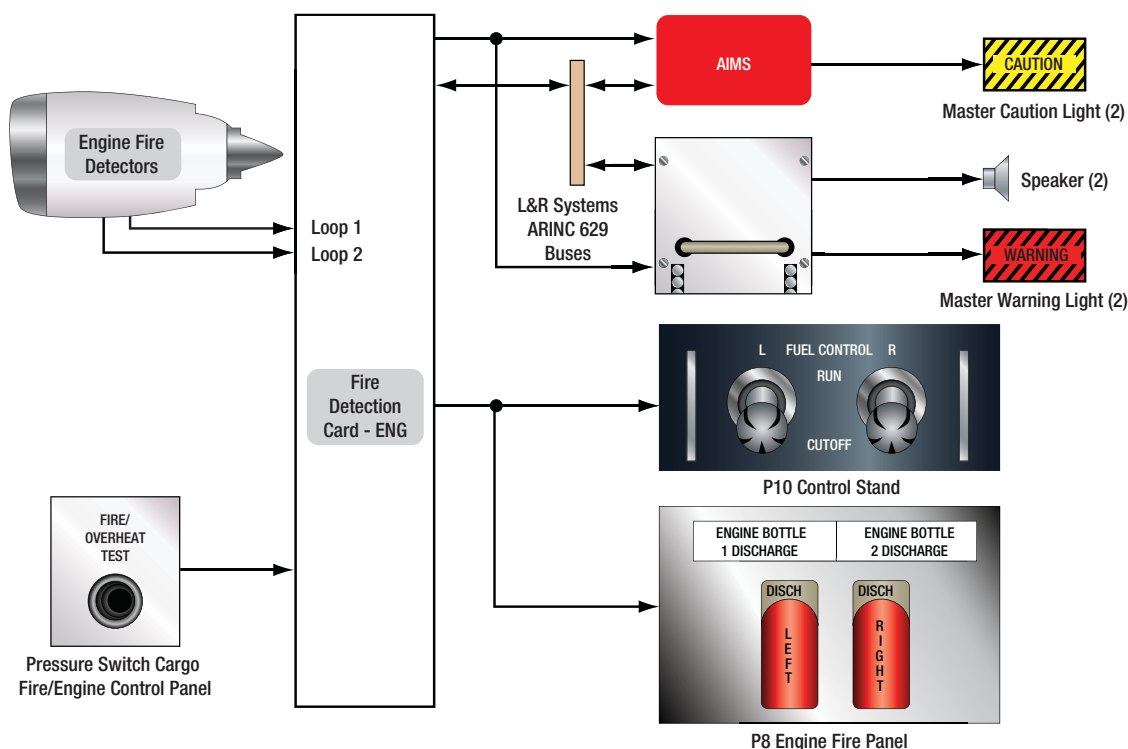

Figure 20-14. Engine fire detection system.

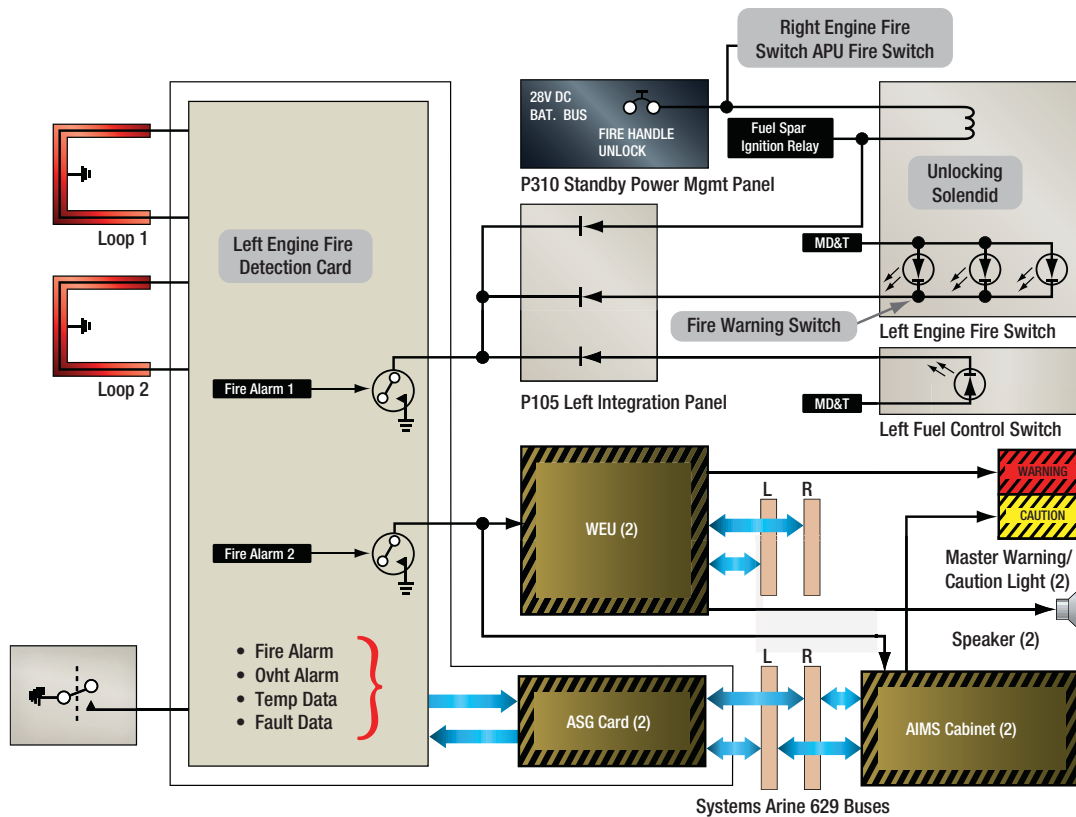

Figure 20-15. Engine fire detection system functional description.

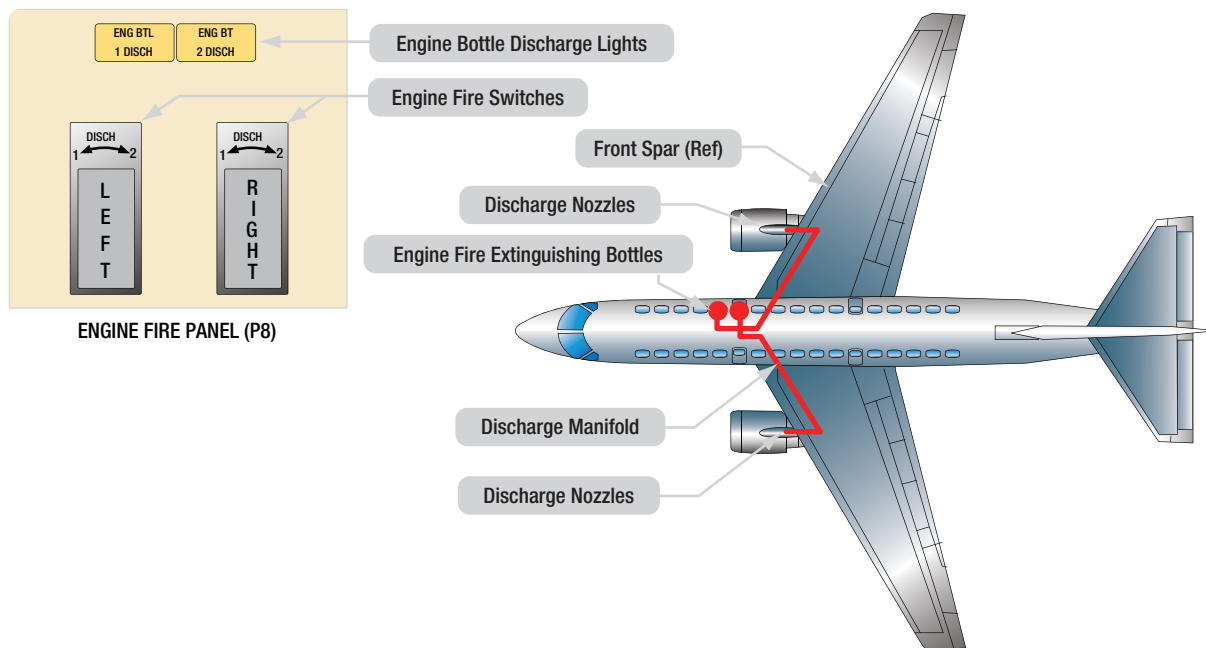

Figure 20-16. Boeing 777 fire extinguisher container location.

has an explosive squib. An electric current from the fire extinguishing circuit fires the squib. This releases the Halon through the discharge port. The pressure switch gives flight deck indications when bottle pressure decreases. The switch monitors the pressure inside the bottle and is normally open. When the pressure

decreases because of a leak or bottle discharge, the switch closes an indicating circuit.

### SQUIB

The squib is installed in the discharge assembly at the bottom of the fire container. A fire container

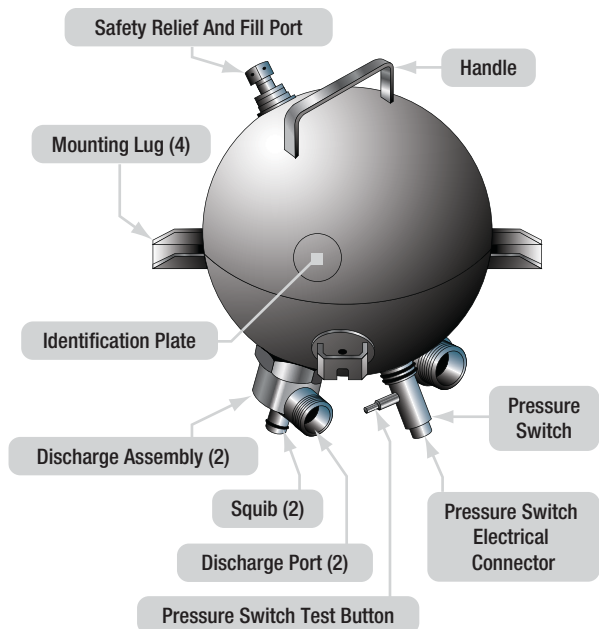

Figure 20-17. Engine fire detection system functional description.

has two squibs, one for each engine. The squib is an electrically operated explosive device. When the squib is activated, it fires a slug through the breakable disk, and nitrogen pressure inside the bottle pushes the Halon through the discharge port. The squib fires when the fire switch is pulled and turned to the DISCH 1 or DISCH 2 position. (Figure 20-16)

### ENGINE FIRE SWITCHES

The engine fire panel is in the flight deck on the P8 aisle stand. The engine fire panel has a fire switch for each engine and a discharge light for each fire bottle. (Figure 20-20)

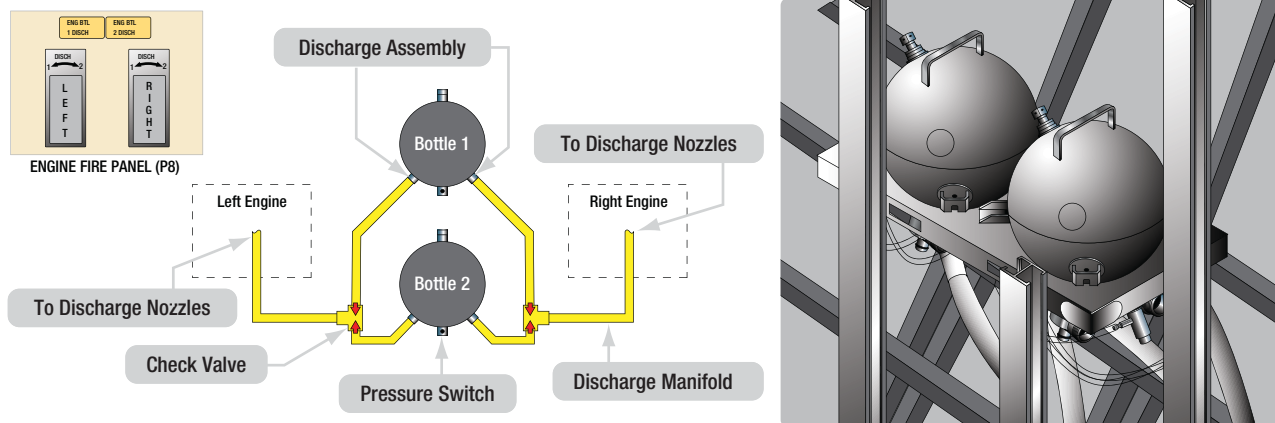

Figure 20-18. Location of fire extinguishing bottles.

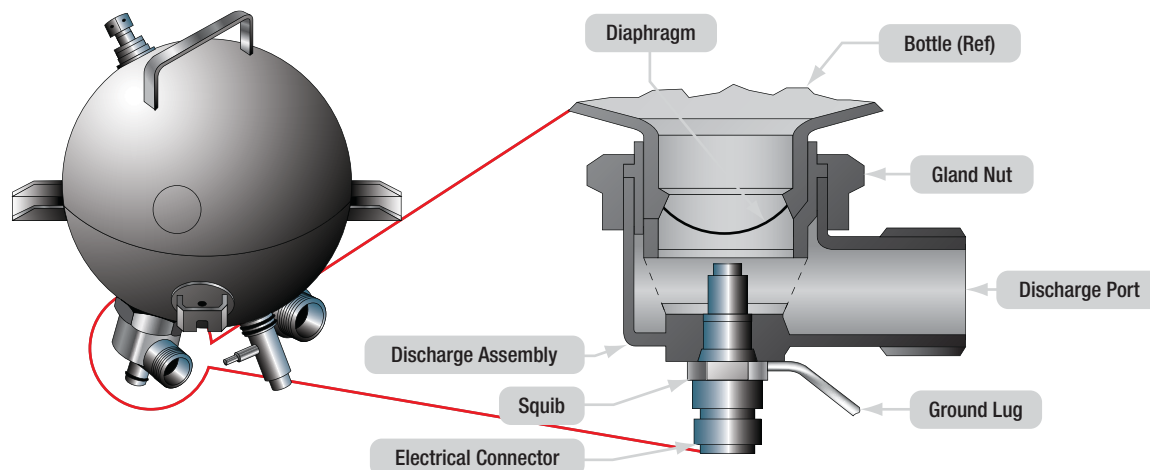

Figure 20-19. Squib or cartridge.

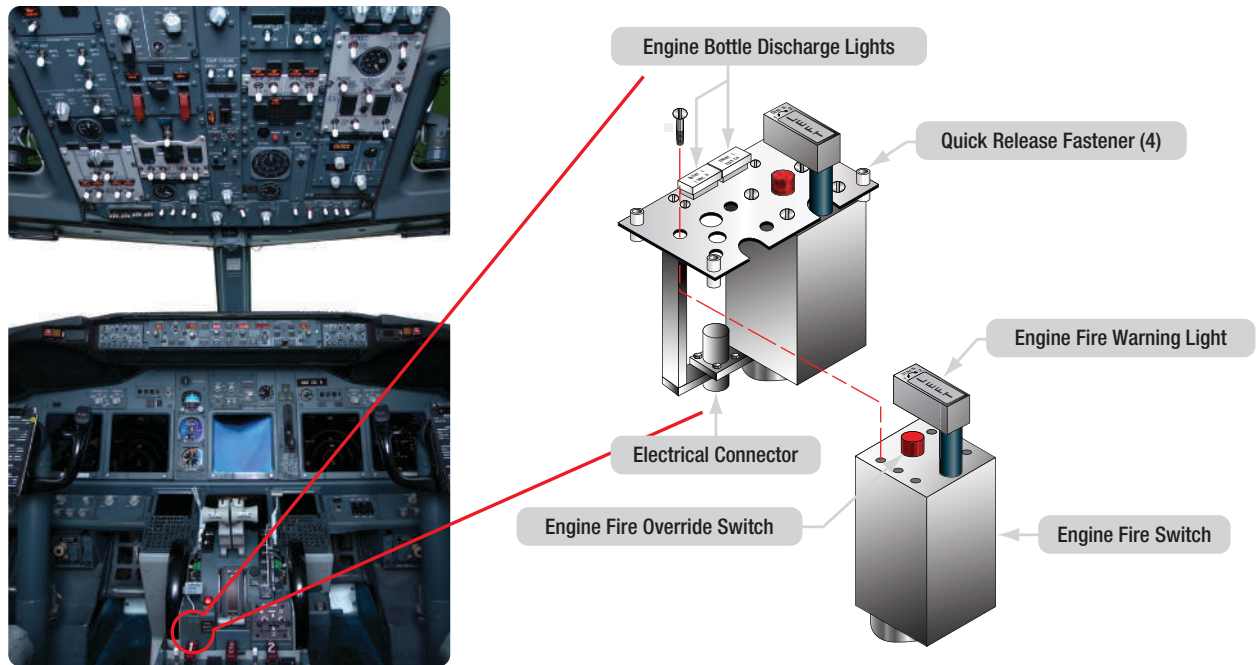

Figure 20-20. Fire switch.

The engine fire switch has four functions:

- Gives an indication of an engine fire
- Stops the engine
- Isolates the engine from the airplane systems
- Controls the engine fire extinguishing system

- Depressurizes the engine driven hydraulic pump valve
- Closes the pressure regulator and shutoff valve
- Removes power from thrust reverser isolation valve
- Trips the generator field
- Trips the backup generator field (*Figure 20-21*)

The fire switch assembly incorporates a solenoid that locks the fire switch so that the flight crew cannot pull it accidentally. If an engine has a fire, the fire warning light comes on and the solenoid energizes to release the switch. When the solenoid is energized, the fire switch can be pulled. When the fire detection system malfunctions or the solenoid is defective and the flight crew wants to extinguish an engine fire, someone must push the fire override switch. The fire override switch allows the fire switch to be pulled when the solenoid is not energized. When the fire switch is pulled, the push-pull switch contacts operate electrical circuits that stop the engine and isolate it from the airplane systems. With the switch pulled, it can be rotated to left or right to a mechanical stop at the discharge position. The rotary switch contacts close and operate the fire extinguishing system.

## ENGINE FIRE OPERATION

If an engine has a fire, the engine fire detection system gives a fire warning in the flight deck. The engine fire warning lights come on to identify which fire switch to use to extinguish the fire. The solenoid in the fire switch energizes and releases the switch so that the fire switch can be pulled. If the solenoid does not energize, push the fire override switch to release the fire switch manually. When the fire switch is pulled, it stops the engine, and the fire switch isolates the engine from the airplane systems. If the fire warnings do not go away when the switch is pulled, position the switch to the DISCH 1 or DISCH 2 position, and hold the switch against the stop for one second. This fires the squib in the fire extinguisher container and releases the fire extinguishing agent into the engine nacelle. Ensure that the engine bottle discharge light comes on. If the first bottle does not extinguish the fire, the switch must be placed to the other DISCH position. This fires the squib for the other bottle.

When the fire switch is pulled, the switch isolates the following aircraft systems from the engine:

- Closes the fuel spar valve
- De-energizes the engine fuel metering unit (FMU) cutoff solenoid
- Closes the engine hydraulic pump shutoff valve

## APU FIRE DETECTION AND EXTINGUISHING SYSTEM

The APU fire protection system is similar in design to engine fire protection systems, but there are some differences. The APU is often operated with no personnel in the flight deck and; the APU fire protection system can operate in an unattended mode on the ground with the engines not running. If there is an APU fire in the unattended mode, the fire extinguisher discharges automatically. The APU operates in the attended mode when at least one engine is running. If there is an APU fire in this mode, the crew discharges the bottle manually. Fire switches are located on the cargo fire/engine control panel and the service and APU shutdown panel located outside the airplane on the nose landing gear. (Figure 20-22)

## APU FIRE WARNING

If there is an APU fire, the APU fire detection system gives fire warnings and automatically stops the APU. The APU fire warning light comes on to identify the correct fire switch to use to extinguish the fire. The fire switch solenoid releases the switch so that it can be pulled up. If the APU is running, it stops when the fire switch is pulled. The fire switch isolates the APU from the airplane systems.

## FIRE BOTTLE DISCHARGE

If the fire warnings do not go away with the switch out, put the switch to the left or right DISCH position. Hold the switch against the discharge stop for one second. This fires the bottle squib and releases the fire extinguishing agent into the APU compartment. Verify that the APU bottle discharge light comes on. (Figure 20-23)

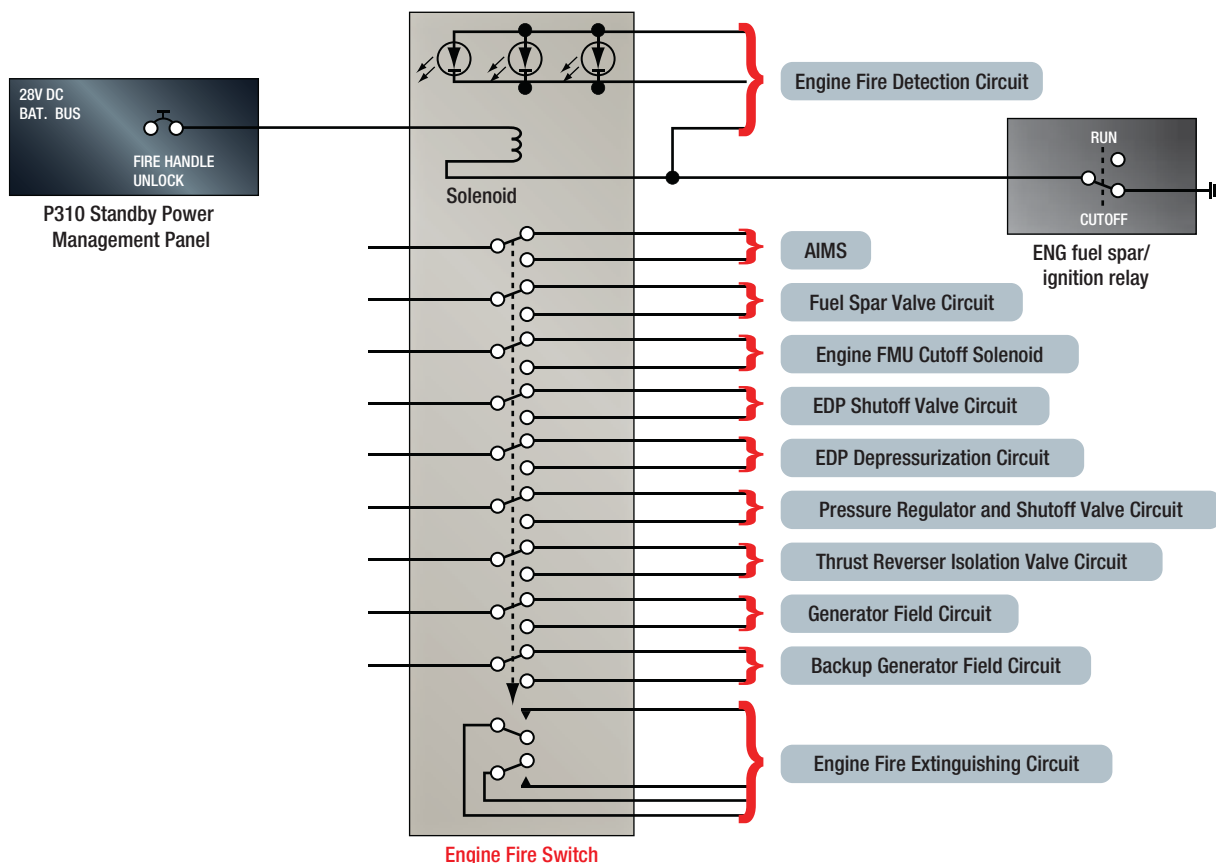

Figure 20-21. Engine fire switch circuit.

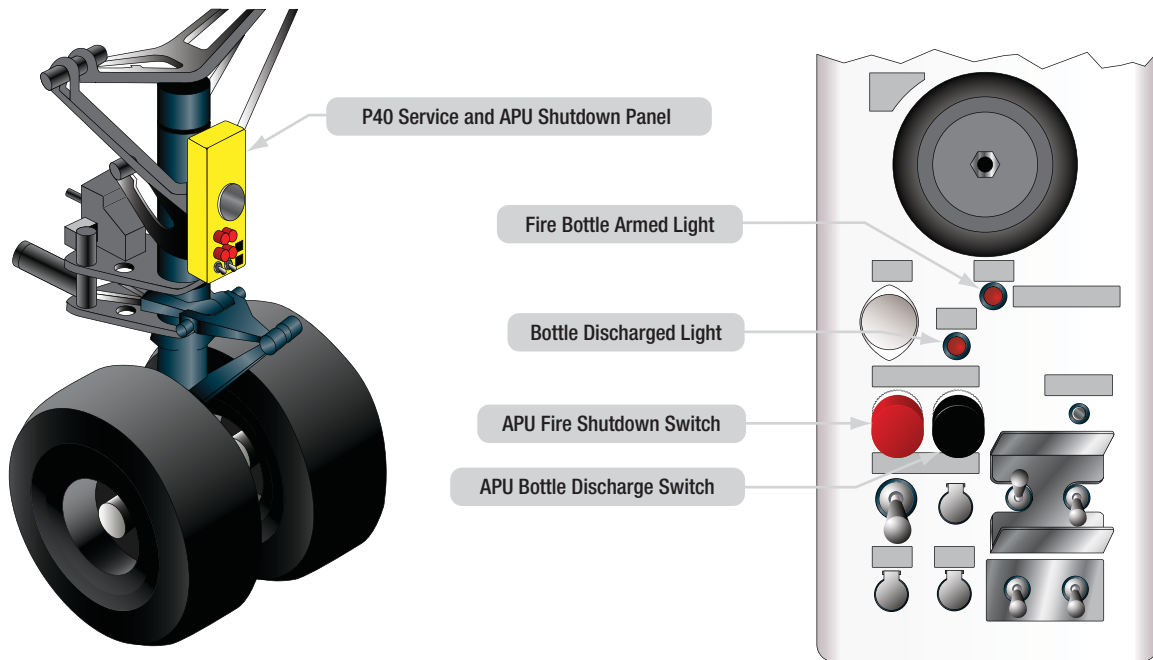

Figure 20-22. P-40 service and APU shutdown panel.

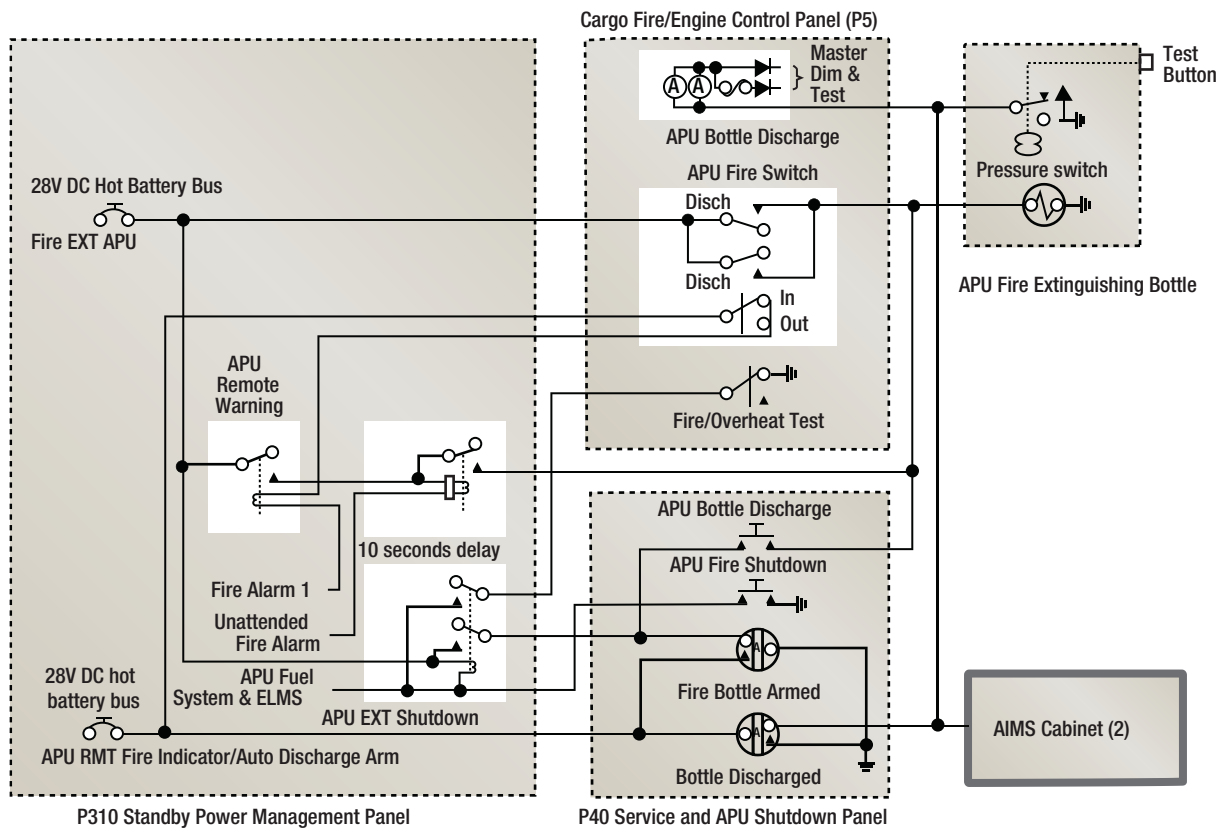

Figure 20-23. APU fire extinguishing circuit.

**Question: 20-1**

A mechanical failures in the turbine section such as \_\_\_\_\_ can lead to an overheat condition or fire.

**Question: 20-5**

When the \_\_\_\_\_ is activated, the engine stops because the fuel control shuts off, the engine is isolated from the aircraft systems, and the fire extinguishing system is activated.

**Question: 20-2**

A complete fire protection system includes both a fire detection and a fire \_\_\_\_\_ system.

**Question: 20-6**

In the dual loop fire detection system of the Boeing 777, how many loops must have a fire or overheat condition to cause the flight deck indications?

**Question: 20-3**

A \_\_\_\_\_ detector, or sensing system, permits more complete coverage of a fire hazard area than any of the spot-type temperature detectors.

**Question: 20-7**

The \_\_\_\_\_ is an electrically operated explosive device used in fire.

**Question: 20-4**

The fixed fire extinguisher systems used in most engine fire protection systems are designed to dilute the atmosphere with an \_\_\_\_\_ agent that does not support combustion.

**Question: 20-8**

Typically, if there is an APU fire in the “unattended mode”, \_\_\_\_\_ will discharge automatically when a fire is detected.



## ANSWERS

*Answer:* 20-1  
fractured or thrown blades.

*Answer:* 20-5  
fire switch.

*Answer:* 20-2  
extinguishing.

*Answer:* 20-6  
both (two).

*Answer:* 20-3  
continuous-loop.

*Answer:* 20-7  
extinguishing systems.

*Answer:* 20-4  
inert.

*Answer:* 20-8  
fire extinguishing agent.



PART-66 SYLLABUS LEVELS  
 CERTIFICATION CATEGORY → **A1** **B1**

**Sub-Module 21**  
**ENGINE MONITORING AND GROUND OPERATION**

Knowledge Requirements

*15.21 - Engine Monitoring and Ground Operation*

- Procedures for starting and ground run-up;
- Interpretation of engine power output and parameters;
- Trend (including oil analysis, vibration and boroscope) monitoring;
- Inspection of engine and components to criteria, tolerances and data specified by engine manufacturer;
- Compressor washing/cleaning;
- Foreign Object Damage.

CERTIFICATION CATEGORY →	A1	B1
	<b>1</b>	<b>3</b>

**Level 1**

A familiarization with the principal elements of the subject.

*Objectives:*

- (a) The applicant should be familiar with the basic elements of the subject.
- (b) The applicant should be able to give a simple description of the whole subject, using common words and examples.
- (c) The applicant should be able to use typical terms.

**Level 3**

A detailed knowledge of the theoretical and practical aspects of the subject and a capacity to combine and apply the separate elements of knowledge in a logical and comprehensive manner.

*Objectives:*

- (a) The applicant should know the theory of the subject and interrelationships with other subjects.
- (b) The applicant should be able to give a detailed description of the subject using theoretical fundamentals and specific examples.
- (c) The applicant should understand and be able to use mathematical formula related to the subject.
- (d) The applicant should be able to read, understand and prepare sketches, simple drawings and schematics describing the subject.
- (e) The applicant should be able to apply his knowledge in a practical manner using manufacturer's instructions.
- (f) The applicant should be able to interpret results from various sources and measurements and apply corrective action where appropriate.

---

# ENGINE MONITORING AND GROUND OPERATION

## TURBINE ENGINE OPERATION

The engine operating procedures presented here apply generally to turbofan, turboprop, turboshaft, and auxiliary power units (APU). The procedures, pressures, temperatures, and rpm that follow are intended primarily to serve as a guide. It should be understood that they do not have general application. The manufacturer's operating instructions should be consulted before attempting to start and operate any turbine engine.

A turbofan engine has only one power control lever. Adjusting the power lever, or throttle lever, sets up a thrust condition for which the fuel control meters fuel to the engine. Engines equipped with thrust reversers go into reverse thrust at throttle positions below idle. A separate fuel shutoff lever is usually provided on engines equipped with thrust reversers.

Prior to start, particular attention should be paid to the engine air inlet, the visual condition and free movement of the compressor and turbine assembly, and the parking ramp area fore and aft of the aircraft. The engine is started by using an external air power source, APU, or an already operating engine. Starter types and the engine starting cycle have been discussed previously. On multi-engine aircraft, the engines are usually started by an onboard APU that supplies the air pressure for a pneumatic starter on each engine. Air bled from the APU is used as a source of power for starting the engines.

During the start, it is necessary to monitor the tachometer, the oil pressure, and the exhaust gas temperature. The normal starting sequence is:

1. Rotate the compressor with the starter;
2. Turn the ignition on; and
3. Open the engine fuel valve, either by moving the throttle to idle or by moving a fuel shutoff lever or turning a switch.

Adherence to the procedure prescribed for a particular engine is necessary as a safety measure and to avoid a hot or hung start. A successful start is noted first by a rise in exhaust gas temperature. If the engine does not light up, meaning that fuel starts to burn inside of the engine within a prescribed period of time, or if the exhaust gas starting temperature limit is exceeded, a hot start, the starting procedure should be aborted.

Hot starts are not common, but when they do occur, they can usually be stopped in time to avoid excessive temperature by observing the exhaust gas temperature constantly during the start. When necessary, the engine is cleared of trapped fuel or gases by continuing to rotate the compressor with the starter, but with the ignition and fuel turned off. If the engine did not light off during start after the allotted time, about 10 seconds although this time varies from engine to engine, the fuel must be shut off as the engine is being filled with unburned fuel. A hung start is when the engine lights off, but the engine will not accelerate to idle rpm.

## GROUND OPERATION ENGINE FIRE

Move the fuel shutoff lever to the off position if an engine fire occurs, or if the fire warning light is illuminated during the starting cycle. Continue cranking or motoring the engine until the fire has been expelled from the engine. If the fire persists, CO<sub>2</sub> can be discharged into the inlet duct while it is being cranked. Do not discharge CO<sub>2</sub> directly into the engine exhaust, because it may damage the engine. If the fire cannot be extinguished, secure all switches and leave the aircraft. If the fire is on the ground under the engine overboard drain, discharge the CO<sub>2</sub> on the ground rather than on the engine. This also is true if the fire is at the tailpipe and the fuel is dripping to the ground and burning.

## ENGINE CHECKS

Checking turbofan engines for proper operation consists primarily of simply reading the engine instruments and then comparing the observed values with those known to be correct for any given engine operating condition. After the engine has started, idle rpm has been attained, and the instrument readings have stabilized, the engine should be checked for satisfactory operation at idling speed. The oil pressure indicator, tachometer, and the exhaust gas temperature readings should be compared with the allowable ranges.

## CHECKING TAKEOFF THRUST

Takeoff thrust is checked by adjusting the throttle to obtain a single, predicted reading on the engine pressure ratio indicator in the aircraft. The value for engine pressure ratio, which represents takeoff thrust for the prevailing ambient atmospheric conditions, is calculated from a takeoff thrust setting curve or, on newer aircraft,

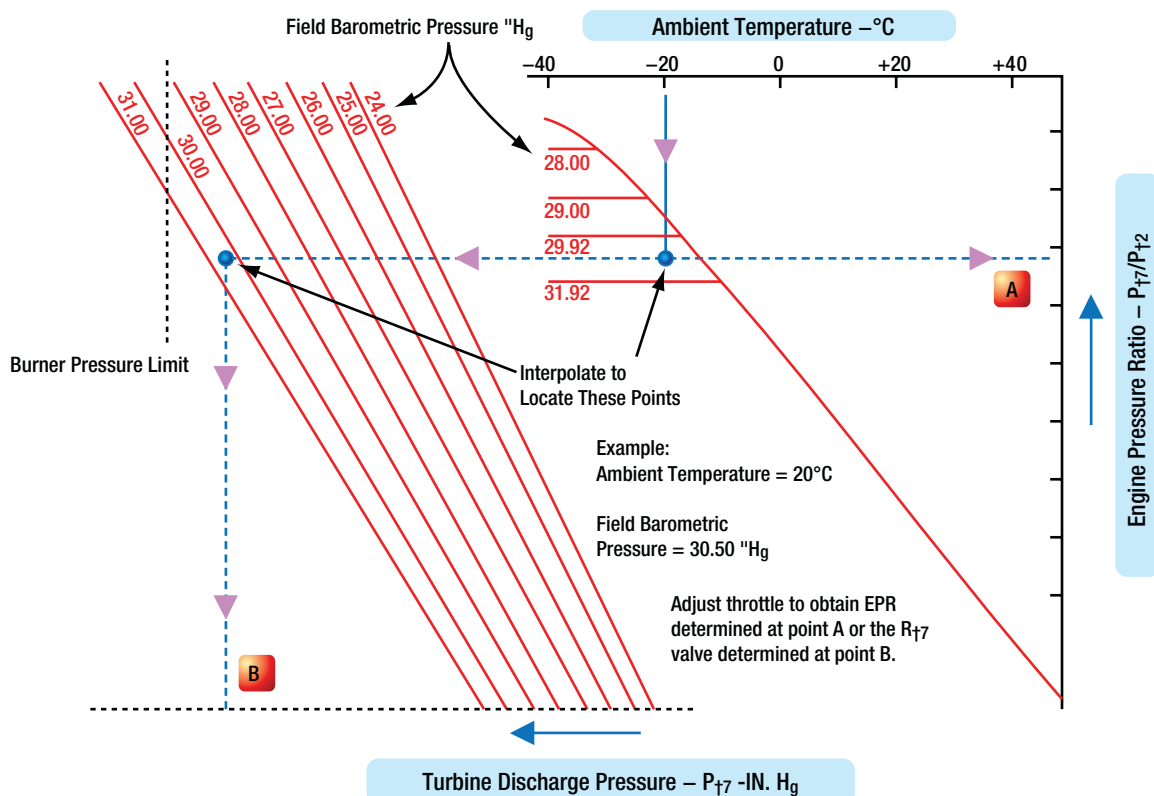

Figure 21-1. Typical takeoff thrust setting curve for static conditions.

is a function of the onboard computer. The curve has been computed for static conditions. (*Figure 21-1*) Therefore, for all precise thrust checking, the aircraft should be stationary, and stable engine operation should be established. If it is needed for calculating thrust during an engine trim check, turbine discharge pressure ( $P_{t7}$ ) is also shown on these curves. Appropriate manuals should be consulted for the charts for a specific make and model engine.

The engine pressure ratio computed from the thrust setting curve represents thrust or a lower thrust called part power thrust used for testing. The aircraft throttle is advanced to obtain this predicted reading on the engine pressure ratio indicator, or the part power stop is engaged in the aircraft. If an engine develops the predicted thrust and if all the other engine instruments are reading within their proper ranges, engine operation is considered satisfactory. Full authority digital engine controls (FADEC) (computer controls) also have means of checking the engine with the results displayed on the flight deck.

## AMBIENT CONDITIONS

The sensitivity of gas turbine engines to compressor inlet air temperature and pressure necessitates that considerable care be taken to obtain correct values for the prevailing ambient air conditions when computing takeoff thrust. Some things to remember are:

1. The engine senses the air temperature and pressure at the compressor inlet. This is the actual air temperature just above the runway surface. When the aircraft is stationary, the pressure at the compressor inlet is the static field or true barometric pressure, and not the barometric pressure corrected to sea level that is normally reported by airport control towers as the altimeter setting. On FADEC engines, the computer reads this information and sends it to the engine controls.
2. Temperature sensed is the total air temperature (TAT) that is used by several onboard computers. The engine controls set the engine computers according to the TAT.
3. Relative humidity, which affects reciprocating engine power appreciably, has a negligible effect on turbine engine thrust, fuel flow, and rpm. Therefore, relative humidity is not usually considered when computing thrust for takeoff or determining fuel flow and rpm for routine operation.

## ENGINE SHUTDOWN

On a turbine engine that does not have a thrust reverser, retarding the aircraft throttle to idle or power lever to OFF cuts the fuel supply to the engine and shuts it down. On engines equipped with thrust reversers, this is accomplished by means of a separate fuel shutoff lever or switch. When an engine has been operated at high power levels for extended periods of time, a cool down time should be allowed before shut down. It is recommended the engine be operated at below a low power setting, preferably at idle for a period of 5 minutes to prevent possible seizure of the rotors. This applies, in particular, to prolonged operation at high rpm on the ground, such as during engine trimming. The turbine case and the turbine wheels operate at approximately the same temperature when the engine is running. However, the turbine wheels are relatively massive, compared with the case, and are not cooled so readily. The turbine case is exposed to cooling air from both inside and outside the engine. Consequently, the case and the wheels lose their residual heat at different rates after the engine has been shut down. The case, cooling faster, tends to shrink upon the wheels that are still rotating.

Under extreme conditions, the turbine blades may squeal or seize; thus a cooling period is required if the engine has been operating at prolonged high speed. Should the turbine wheels seize, no harm normally results, provided no attempt is made to turn the engine over until it has cooled sufficiently to free the wheels. In spite of this, every effort should be made to avoid seizure.

To ensure that fuel remains in the lines and that the engine driven fuel pumps are not starved for fuel that lubricates the pumps, the aircraft fuel boost pump must be turned off after, not before, the throttle or the fuel shutoff lever is placed in the OFF position.

Generally, an engine should not be shut down by the fuel shutoff lever until after the aircraft throttle has been retarded to idle. Because the fuel shutoff valve is located on the fuel control discharge, a shutdown from high thrust settings results in high fuel pressures within the control that can harm the fuel system parts.

When an accurate reading of the oil level in the oil tank is needed following an engine shutdown, the engine should be operated and shut down with the oil check taking place within not more than 30 minutes after shutdown. Check the engine manuals for specific procedure.

---

## TURBOPROP OPERATION

Turboprop engine operation is quite similar to that of a turbojet engine, except for the added feature of a propeller. The starting procedure and the various operational features are very much alike. The turboprop chiefly requires attention to engine operating limits, the throttle or power lever setting, and the torque meter pressure gauge. Although torque meters indicate only the power being supplied to the propeller and not the equivalent shaft horsepower, torque meter pressure is approximately proportional to the total power output

and, thus, is used as a measure of engine performance. The torque meter pressure gauge reading during the takeoff engine check is an important value. It is usually necessary to compute the takeoff power in the same manner as is done for a turbojet engine. This computation is to determine the maximum allowable exhaust gas temperature and the torque meter pressure that a normally functioning engine should produce for the outside, or ambient, air temperature and barometric pressure prevailing at the time.

---

## TROUBLESHOOTING TURBINE ENGINES

Included in this section are typical guidelines for locating engine malfunctions on most turbine engines. Since it would be impractical to list all the malfunctions that could occur, only the most common malfunctions are covered. A thorough knowledge of the engine systems, applied with logical reasoning solves most problems that may occur.

*Figure 21-2* enumerates some malfunctions that may

be encountered. Possible causes and suggested actions are given in the adjacent columns. The malfunctions presented herein are solely for the purpose of illustration and should not be construed to have general application. For exact information about a specific engine model, consult the applicable manufacturer's instructions.

Indicated Malfunction	Probable Causes	Suggested Action
Engine has low rpm, exhaust gas temperature, and fuel flow when set to expected engine pressure ratio.	<ul style="list-style-type: none"> <li>Engine pressure ratio indication has high reading error.</li> </ul>	<ul style="list-style-type: none"> <li>Check inlet pressure line from probe to transmitter for leaks.</li> <li>Check engine pressure ratio transmitter and indicator for accuracy.</li> </ul>
Engine has high rpm, exhaust gas temperature, and fuel flow when set to expect engine pressure ration.	<ul style="list-style-type: none"> <li>Engine pressure ratio indication has low reading error due to:               <ul style="list-style-type: none"> <li>Misaligned or cracked turbine discharge probe.</li> <li>Leak in turbine discharge pressure line from probe to transmitter.</li> <li>Inaccurate engine pressure ratio transmitter or indicator.</li> <li>Carbon particles collected in turbine discharge pressure line or restrictor orifices.</li> </ul> </li> </ul>	<ul style="list-style-type: none"> <li>Check probe condition.</li> <li>Pressure-test turbine discharge pressure line for leaks.</li> <li>Check engine pressure ratio transmitter and indicator for accuracy.</li> </ul>
Engine has high exhaust gas temperature, low rpm, and high fuel flow at all engine pressure ratio settings.	<ul style="list-style-type: none"> <li>Possible turbine damage and/or loss of turbine efficiency.</li> </ul>	<ul style="list-style-type: none"> <li>Confirm indication of turbine damage by:               <ul style="list-style-type: none"> <li>Checking engine coast-down for abnormal noise and reduced time.</li> <li>Visually inspect turbine area with strong light</li> </ul> </li> </ul>
NOTE: Engines with damage in turbine section may have tendency to hang up during starting.	<ul style="list-style-type: none"> <li>If only exhaust gas temperature is high, other parameters normal, the problem may be thermocouple leads or instrument.</li> </ul>	<ul style="list-style-type: none"> <li>Re-calibrate exhaust gas temperature instrumentation.</li> </ul>
Engine vibrates throughout rpm range, but indicated amplitude reduces as rpm is reduced.	<ul style="list-style-type: none"> <li>Turbine damage.</li> </ul>	<ul style="list-style-type: none"> <li>Check turbine as outlined in preceding item.</li> </ul>
Engine vibrates at high rpm and fuel flow when compared to constant engine pressure ratio.	<ul style="list-style-type: none"> <li>Damage in compressor section.</li> </ul>	<ul style="list-style-type: none"> <li>Check compressor section for damage.</li> </ul>
Engine vibrates throughout rpm range, but is more pronounced in cruise or idle rpm range.	<ul style="list-style-type: none"> <li>Engine-mounted accessory such as constant-speed drive, generator, hydraulic pump, etc.</li> </ul>	<ul style="list-style-type: none"> <li>Check each component in turn.</li> </ul>
No change in power setting parameters, but oil temperature high.	<ul style="list-style-type: none"> <li>Engine main bearings.</li> </ul>	<ul style="list-style-type: none"> <li>Check scavenge oil filters and magnetic plugs.</li> </ul>
Engine has higher than normal exhaust gas temperature during takeoff, climb, and cruise. Rpm and fuel flow higher than normal.	<ul style="list-style-type: none"> <li>Engine bleed-air valve malfunction.</li> <li>Turbine discharge pressure probe or line to transmitter leaking.</li> </ul>	<ul style="list-style-type: none"> <li>Check operation of bleed valve.</li> <li>Check condition of probe and pressure line to transmitter.</li> </ul>
Engine has high exhaust gas temperature at target engine pressure ratio for takeoff.	<ul style="list-style-type: none"> <li>Engine out of trim.</li> </ul>	<ul style="list-style-type: none"> <li>Check engine with jetcal. Re-trim as desired.</li> </ul>

Figure 21-2. Troubleshooting turbojet engines. (Continued on next page.)

## TROUBLESHOOTING PROCEDURES FOR TURBOPROP ENGINES

All test run-ups, inspections, and troubleshooting should be performed in accordance with the applicable engine manufacturer's instructions. In *Figure 21-3*, the

troubleshooting procedure for the turboprop reduction gear, torque meter, and power section are combined because of their inter-relationships. The table includes the principal troubles, together with their probable causes and remedies.

---

## SPECTROMETRIC OIL ANALYSIS PROGRAM

The Spectrometric Oil Analysis Program allows an oil sample to be analyzed and searched for the presence of minute metallic elements. Due to oil circulation throughout an aircraft engine, every lubricant that is in service contains microscopic particles of metallic elements called wear metals. As the engine operates over time, the oil picks up very small particles that stay suspended in the oil. Oil analysis programs identify and measure these particles in parts per million (PPM) by weight. The analyzed elements are grouped into categories, such as wear metals and additives, and their measurement in PPM provides data that expert analysts can use as one of many tools to determine the engine's condition. An increase in PPM of certain materials can be a sign of component wear or impending failure of the engine. When you read an analysis report, note and record the amount of wear metals. If the amount of wear metals increases beyond a normal rate, then the operator can be notified quickly so repair or a recommend specific maintenance procedure or inspection can be ordered.

Oil analysis increases safety by identifying an engine problem before engine failure. It also saves money by finding engine problems before they become large problems or complete engine failure. This procedure can be used for both turbine and reciprocating engines.

## TYPICAL WEAR METALS AND ADDITIVES

The following examples of wear metals are associated with areas of the engine that could be their source. Identifying the metal can help identify the engine components that are wearing or failing.

Note: piston engine metal sources are included.

- Iron—wear from rings, shafts, gears, valve train, cylinder walls, and pistons in some engines.
- Chromium—primary sources are chromed parts (such as rings, liners, etc.) and some coolant additives.
- Nickel—secondary indicator of wear from certain types of bearings, shafts, valves, and valve guides.
- Aluminum—indicates wear of pistons, rod bearings, and certain types of bushings.
- Lead—mostly from tetraethyl lead contamination.
- Copper—wear from bearings, rocker arm bushings, wrist pin bushings, thrust washers, and other bronze or brass parts, and oil additive or anti-seize compound.
- Tin—wear from bearings.
- Silver—wear of bearings that contain silver and, in some instances, a secondary indicator of oil cooler problems.
- Titanium—alloy in high-quality steel for gears and bearings.
- Molybdenum—gear or ring wear and used as an additive in some oils.
- Phosphorous—antirust agents, spark plugs, and combustion chamber deposits.

---

## VIBRATION

As mentioned previously in *Sub-Module 14 - Engine Indicating Systems*, monitoring turbine engine spools for vibration can be part of the on-board aircraft monitoring capability or an independent vibration monitoring device can be used. Follow the manufacturer's instructions on use of any vibration monitoring devices and consult the

engine maintenance manual for acceptable limits. For more information, see *Sub-Module 14*.

Trouble	Probable Causes	Remedy
Power unit fails to turn over during attempted start.	<ul style="list-style-type: none"> <li>No air to starter.</li> <li>Propeller brake locked.</li> </ul>	<ul style="list-style-type: none"> <li>Check started air valve solenoid and air supply.</li> <li>Unlock brake by turning propeller by hand in direction of normal rotation.</li> </ul>
Power unit fails to start.	<ul style="list-style-type: none"> <li>Starter speed low because of inadequate air supply to starter.</li> <li>If fuel is not observed leaving the exhaust pipe during start, fuel selector valve may be inoperative because of low power supply or may be locked in "OFF."</li> <li>Fuel pump inoperative.</li> <li>Aircraft fuel filter dirty.</li> <li>Fuel control cutoff valve closed.</li> </ul>	<ul style="list-style-type: none"> <li>Check starter air valve solenoid and air supply.</li> <li>Check power supply or electrically operated valves. Replace valves if defective.</li> <li>Check pump for sheared drives or internal damage. Check for air leaks at outlet.</li> <li>Clean filter and replace filtering elements if necessary.</li> <li>Check electrical circuit to ensure that actuator is being energized. Replace actuator or control.</li> </ul>
Engine fires, but will not accelerate to correct speed.	<ul style="list-style-type: none"> <li>Insufficient fuel supply to control unit.</li> <li>Fuel control main metering valve sticking.</li> <li>Fuel control bypass valve sticking open.</li> <li>Drain valve stuck open. Starting fuel enrichment pressure switch setting too high.</li> </ul>	<ul style="list-style-type: none"> <li>Check fuel system to ensure all valves are open and pumps are operative.</li> <li>Flush system. Replace control.</li> <li>Flush system. Replace control.</li> <li>Replace drain valve. Replace pressure switch.</li> </ul>
Acceleration temperature too high during starting.	<ul style="list-style-type: none"> <li>Fuel control bypass valve sticking closed.</li> <li>Fuel control acceleration cam incorrectly adjusted.</li> <li>Defective fuel nozzle.</li> <li>Fuel control thermostat failure.</li> </ul>	<ul style="list-style-type: none"> <li>Flush system. Replace control.</li> <li>Replace control.</li> <li>Replace nozzle with a known satisfactory unit.</li> <li>Replace control.</li> </ul>
Acceleration temperature during starting too low.	<ul style="list-style-type: none"> <li>Acceleration cam of fuel control incorrectly adjusted.</li> </ul>	<ul style="list-style-type: none"> <li>Replace control.</li> </ul>
Engine speed cycles after start.	<ul style="list-style-type: none"> <li>Unstable fuel control governor operation.</li> </ul>	<ul style="list-style-type: none"> <li>Continue engine operation to allow control to condition itself.</li> </ul>
Power unit oil pressure drops off severely.	<ul style="list-style-type: none"> <li>Oil supply low.</li> <li>Oil pressure transmitter or indicator giving false indication.</li> </ul>	<ul style="list-style-type: none"> <li>Check oil supply and refill as necessary.</li> <li>Check transmitter or indicator and repair or replace if necessary.</li> </ul>
Oil leakage at accessory drive seals.	<ul style="list-style-type: none"> <li>Seal failure.</li> </ul>	<ul style="list-style-type: none"> <li>Replace seal or seals.</li> </ul>
Engine unable to reach maximum controlled speed of 100 percent.	<ul style="list-style-type: none"> <li>Faulty propeller governor.</li> <li>Faulty fuel control or air sensing tip.</li> </ul>	<ul style="list-style-type: none"> <li>Replace propeller control assembly.</li> <li>Replace faulty control. If dirty, use air pressure in reverse direction of normal flow through internal engine passage and sensing tip.</li> </ul>
Vibration indication high.	<ul style="list-style-type: none"> <li>Vibration pickup or vibration meter malfunction.</li> </ul>	<ul style="list-style-type: none"> <li>Calibrate vibration meter.</li> <li>Start engine and increase power gradually.</li> <li>Observe vibration indicator. If indications prove pickup to be at fault, replace it. If high vibration remains as originally observed, remove power unit for overhaul.</li> </ul>

Figure 21-3. Troubleshooting turboprop engines.



---

## BORESCOPE

A borescope is an optical viewing device that is inserted through a small opening in an engine case to view the inside of the engine. A simple borescope may have a rigid or flexible fiber optic wand. A light is projected into the wand which shines on the area where the tip of the wand is positioned. The other end of the wand has an eyepiece for viewing by the user. Some borescopes magnify. Other more modern borescopes are digital cameras capable of capturing still and video images. (Figure 21-4)

Turbine engines provide hours of reliable service while requiring relatively little maintenance. When a problem with the interior gas path of the engine is suspected, provisions for borescoping the engine allow the technician to see the area of concern without the lengthy process of disassembling the engine. Many engines are manufactured with ports that are plugged during normal operation but that can be removed to give borescope access to important areas inside the engine. Periodic borescope inspections may be required on some engines. (Figure 21-5)



Figure 21-4. Borescope video monitor and video recorder.

---

## TURBINE ENGINE MAINTENANCE

Turbine powerplant maintenance procedures vary widely according to the design and construction of the particular engine being serviced. The detailed procedures recommended by the engine manufacturer should be followed when performing inspections or maintenance. Maintenance information presented in this section is not intended to specify the exact manner in which maintenance operations are to be performed, but is included to convey a general idea of the procedures involved. For inspection purpose, the turbine engine is divided into two main sections: the cold and hot.

### COMPRESSOR SECTION

Maintenance of the compressor, or cold section, is one of concern because damage to blades can cause engine failure. Much of the damage to the blades arises from foreign matter being drawn into the turbine engine air intakes. The atmosphere near the ground is filled with tiny particles of dirt, oil, soot, and other foreign matter. A large volume of air is introduced into the compressor, and centrifugal force throws the dirt particles outward so that they build up to form a coating on the casing, the vanes, and the compressor blades. Accumulation of dirt on the compressor blades reduces the aerodynamic efficiency of the blades with resultant deterioration in engine performance. The efficiency of the blades is

impaired by dirt deposits in a manner similar to that of an aircraft wing under icing conditions. Unsatisfactory acceleration and high exhaust gas temperature can result from foreign deposits on compressor components.

An end result of foreign particles, if allowed to accumulate in sufficient quantity, would be inefficiency. The condition can be remedied by periodic inspection, cleaning, and repair of compressor components.

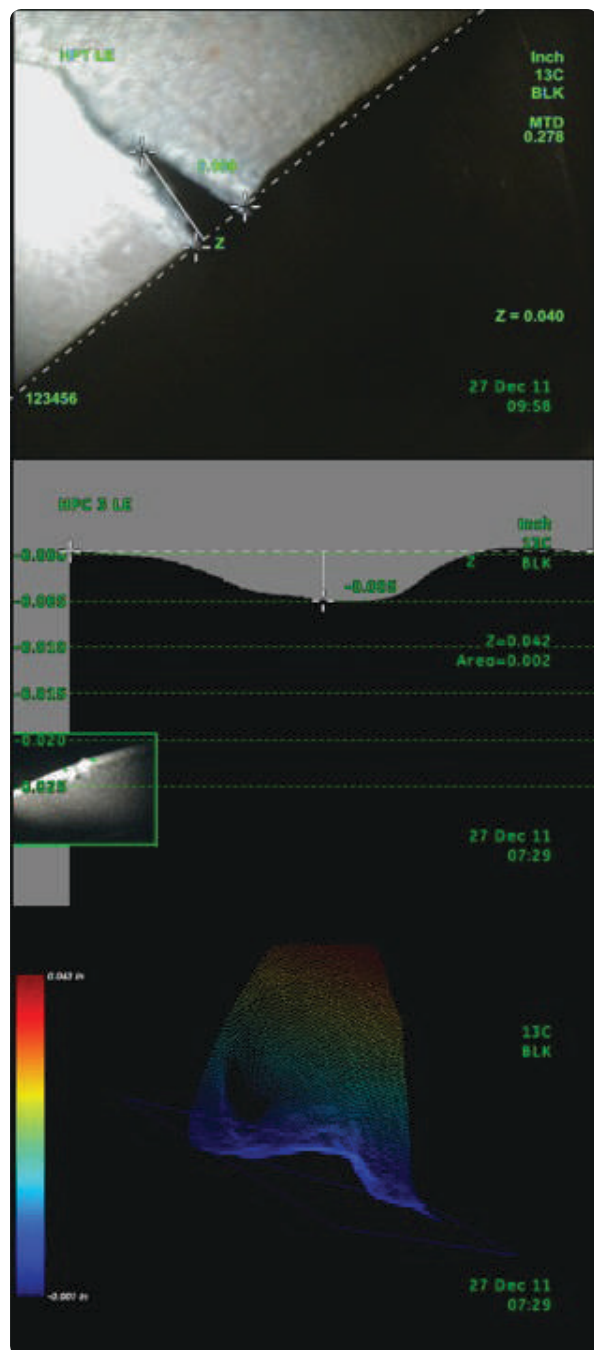

Figure 21-5. Boreoscope images.

## INSPECTION AND CLEANING

Minor damage to axial-flow engine compressor blades may be repaired if the damage can be removed without exceeding the allowable limits established by the manufacturer. Typical compressor blade repair limits are shown in **Figure 21-6**. Well-rounded damage to leading and trailing edges that is evident on the opposite side of the blade is usually acceptable without re-work, provided the damage is in the outer half of the blade only, and the indentation does not exceed values specified in the engine manufacturer's service and overhaul instruction manuals. When working on the inner half of the blade, damage must be treated with extreme caution. Repaired compressor blades are inspected by either magnetic particle or fluorescent penetrant inspection methods to ensure that all traces of the damage have been removed. All repairs must be well blended so that surfaces are smooth. (**Figure 21-7**) No cracks of any extent are tolerated in any area.

Whenever possible, stoning and local re-work of the blade should be performed parallel to the length of the blade. Rework must be accomplished by hand, using stones, files, or emery cloth. Do not use a power tool to buff the entire area of the blade. The surface finish in the repaired area must be comparable to that of a new blade. On centrifugal flow engines, it is difficult to inspect the compressor inducers without first removing the air-inlet screen. After removing the screen, clean the compressor inducer and inspect it with a strong light. Check each vane for cracks by slowly turning the compressor. Look for cracks in the leading edges. A crack is usually cause for component rejection. The compressor inducers are normally the parts that are damaged by the impingement of foreign material during engine operation.

Compressor inducers are repaired by stoning out and blending the nicks and dents in the critical band (1½ to 2½ inches from the outside edge), if the depth of such nicks or dents does not exceed that specified in the engine manufacturer's service or overhaul instruction manuals. Repair nicks by stoning out material beyond the depth of damage to remove the resulting cold-worked metal. A generous radius must be applied at the edges of the blend. After blending the nick, it should be smoothed over with a crocus cloth. Pitting nicks or corrosion found on the sides of the inducer vanes are similarly removed by blending.

Maximum Allowable Repair Limits-Inches				
Blade Area	Steel Blades		Titanium Blades	
	Stages		Stages	
	1 through 4	5 through 9	1 through 4	5 through 9
A	5/16 R	1/4 R	5/16 R	1/4 R
B	1/32 D	1/32 D	1/32 D	1/32 D
C	5/32 D	1/8 D	5/32 D	1/8 D
D	.008 D	.005 D	NONE	NONE
E	1/32 D	1/32 D	1/32 D	1/32 D

R—Radius D—Depth

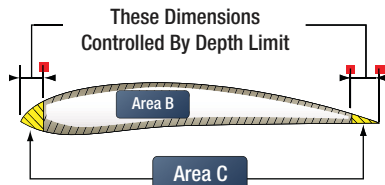

**CAUTION**

The limits referred to in this figure in areas Area E and Area C and pertain to local, isolated, damaged areas only must not be interpreted as authority for removal of material all across the tip and leading or trailing edges as might be done in a single machining cut.

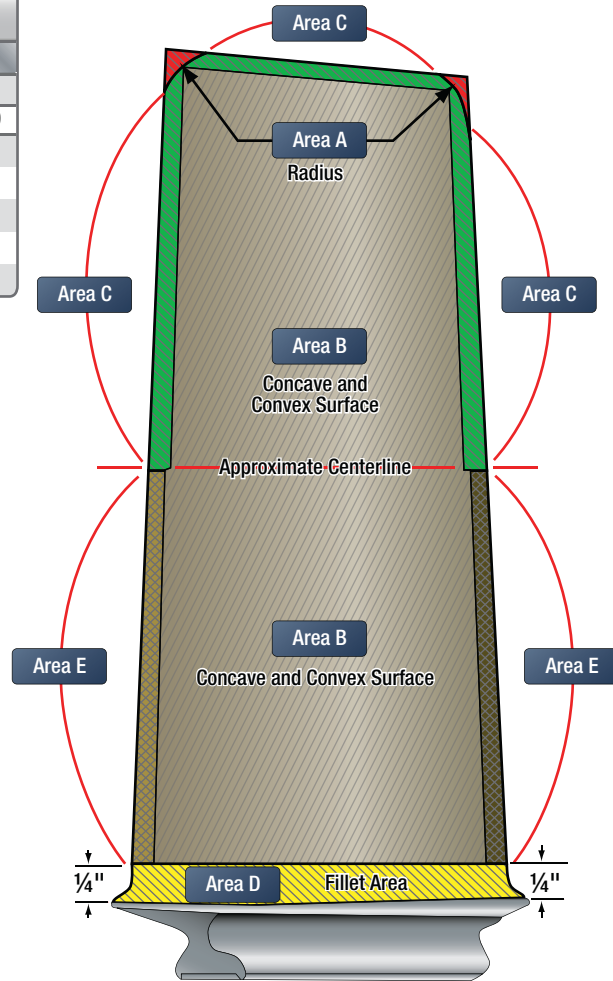
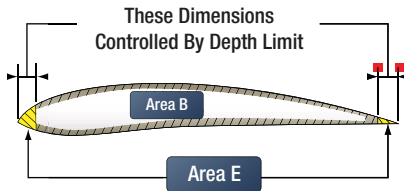

Figure 21-6. Typical compressor blade repair limit.

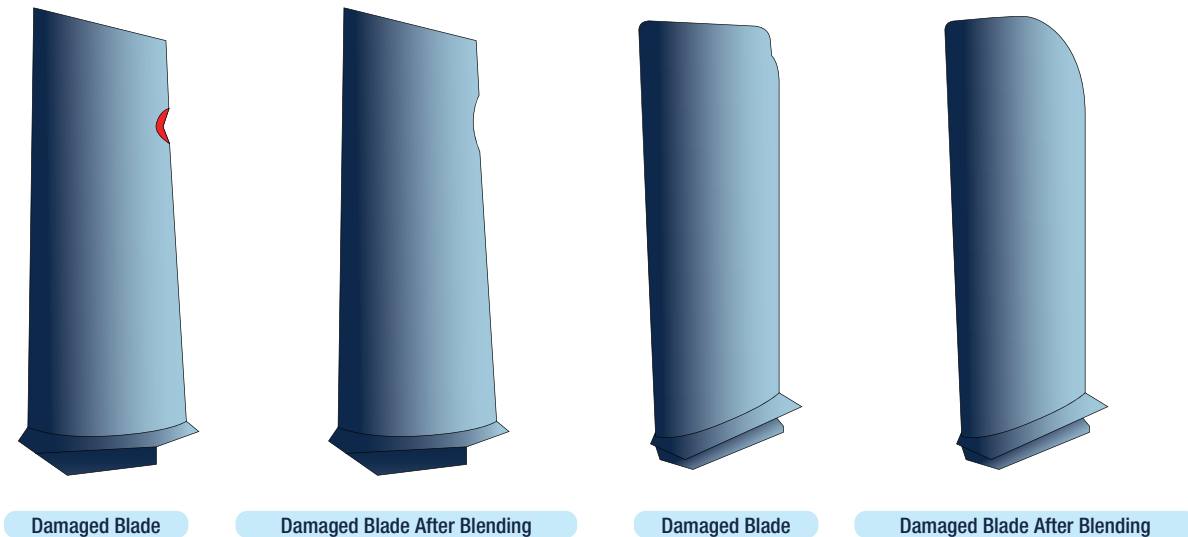

Figure 21-7. Examples of repairs to damaged blades.

### CAUSES OF BLADE DAMAGE

Loose objects often enter an engine either accidentally or through carelessness. Foreign object damage (FOD), such as pencils, tools, and flashlights, are often drawn

into the engine and can cause damage to the fan blades. (Figure 21-8) Do not carry any objects in pockets when working around operational turbine engines.



Figure 21-8. Fan blade damage.

A compressor rotor can be damaged beyond repair by tools that are left in the air intake, where they are drawn into the engine on subsequent starts. A simple solution to the problem is to check the tools against a tool checklist. Prior to starting a turbine engine, make a minute inspection of engine inlet ducts to assure that items, such as nuts, bolts, lock wire, or tools, were not left there after work had been performed.

**Figure 21-9** shows some examples of blade damage to an axial-flow engine. The descriptions and possible causes of blade damage are given in **Figure 21-10**. Corrosion pitting is not considered serious on the compressor stator vanes of axial-flow engines if the pitting is within the allowed tolerance. Do not attempt to repair any vane by straightening, brazing, welding, or soldering. Crocus cloth, fine files, and stones are used to blend out damage by removing a minimum of material and leaving a surface finish comparable to that of a new part. The

purpose of this blending is to minimize stresses that concentrate at dents, scratches, or cracks.

The inspection and repair of air intake guide vanes, swirl vanes, and screens on centrifugal-flow engines necessitates the use of a strong light. Inspect screen assemblies for breaks, rips, or holes. Screens may be tin-dipped to tighten the wire mesh, provided the wires are not worn too thin. If the frame strip or lugs have separated from the screen frames, re-brazing may be necessary. Inspect the guide and swirl vanes for looseness. Inspect the outer edges of the guide vanes, paying particular attention to the point of contact between the guides and swirl vanes for cracks and dents due to the impingement of foreign particles. Inspect the edges of the swirl vanes. Inspect the downstream edge of the guide vanes very closely, because cracks are generally more prevalent in this area. Cracks that branch or fork out so that a piece of metal could break free and fall into the compressor are cause for vane rejection.

### BLENDING AND REPLACEMENT

Because of the thin-sheet construction of hollow vanes, blending on the concave and convex surfaces, including the leading edge, is limited. Small, shallow dents are acceptable if the damage is of a rounded or gradual contour type and not a sharp or V-type, and if no cracking or tearing of vane material is evident in the damaged area.

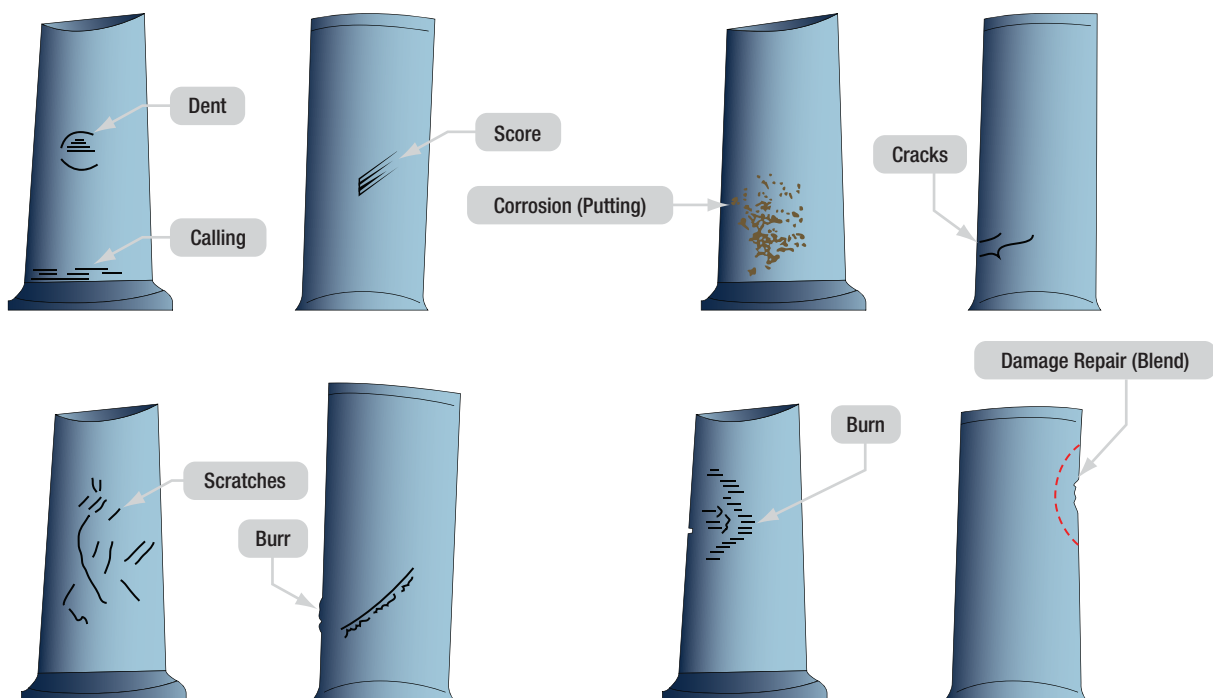

Figure 21-9. Compressor blade damage

Term	Appearance	Usual Causes
• Blend	• Smooth repair of ragged edge or surface into the contour of surrounding area.	
• Bow	• Bent blade.	• Foreign objects.
• Burning	• Damage to surfaces evidenced by discoloration or, in severe cases, by flow of material.	• Excessive heat.
• Burr	• A ragged or turned out edge.	• Grinding or cutting operation.
• Corrosion (pits)	• Breakdown of the surface; pitted appearance.	• Corrosive agents—moisture, etc.
• Cracks	• A partial fracture (separation).	• Excessive stress due to shock, overloading, or faulty processing; defective materials; overheating.
• Dent	• Small, smoothly rounded hollow.	• Striking of a part with a dull object.
• Gall	• A transfer of metal from one surface to another	• Severe rubbing.
• Gouging	• Displacement of material from a surface; a cutting or tearing effect.	• Presence of a comparatively large foreign body between moving parts.
• Growth	• Elongation of blade.	• Continued and/or excessive heat and centrifugal force.
• Pit	• (See corrosion).	
• Profile	• Contour of a blade or surface.	
• Score	• Deep scratches.	• Presence of chips between surfaces.
• Scratch	• Narrow shallow marks.	• Sand or fine foreign particles; careless handling.

Figure 21-10. Blade maintenance terms.

Trailing edge damage may be blended, if one-third of the weld seam remains after repair. (*Figure 21-11*) Concave surfaces of rubber-filled vanes may have allowable cracks extending inward from the outer airfoil, provided there is no suggestion of pieces breaking away. Using a light and mirror, inspect each guide vane trailing edge and vane body for cracks or damage caused by foreign objects. Any inspection and repair of turbine compressor section components require that the technician always use the specific manufacturer's current information for evaluation and limits of repairs.

## COMBUSTION SECTION INSPECTION

One of the controlling factors in the service life of the turbine engine is the inspection and cleaning of the hot section. Emphasis must be placed on the importance of careful inspection and repair of this section.

The following are general procedures for performing a hot section (turbine and combustion section) inspection. It is not intended to imply that these procedures are to be followed when performing repairs or inspections on turbine engines. However, the various practices are typical of those used on many turbine

engines. Where a clearance or tolerance is shown, it is for illustrative purposes only. Always follow the instructions contained in the applicable manufacturer's maintenance and overhaul manuals.

The entire external combustion case should be inspected for evidence of hotspots, exhaust leaks, and distortions before the case is opened. After the combustion case has been opened, the combustion chambers can be inspected for localized overheating, cracks, or excessive wear. (*Figure 21-12*) Inspect the first stage turbine blades and nozzle guide vanes for cracks, warping, or FOD. Also inspect the combustion chamber outlet ducts and turbine nozzle for cracks and for evidence of FOD.

One of the most frequent discrepancies that are detected while inspecting the hot section of a turbine engine is cracking. These cracks may occur in many forms, and the only way to determine that they are within acceptable limits or if they are allowed at all, is to refer to the applicable engine manufacturer's service and overhaul manuals.

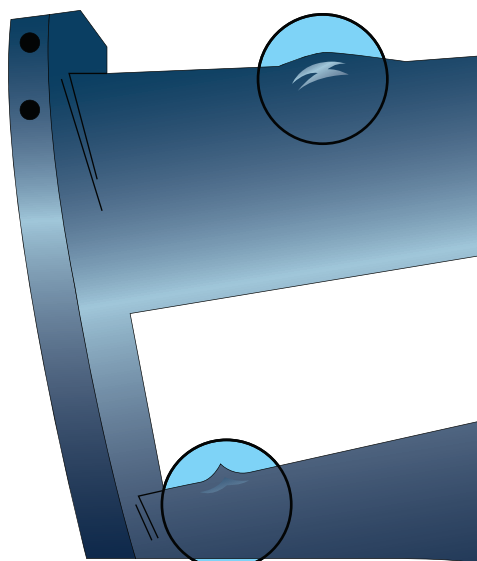

Before Blending

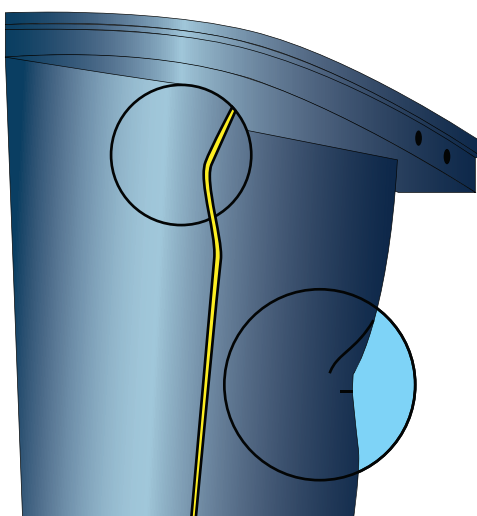

After Blending

Figure 21-11. Guide vane trailing edge damage.



Figure 21-12. Combustion case inspection.

Cleaning the hot section is not usually necessary for a repair in the field, but in areas of high salt water or other chemicals a turbine rinse should be accomplished.

Engine parts can be degreased by using the emulsion-type cleaners or chlorinated solvents. The emulsion-type cleaners are safe for all metals, since they are neutral and noncorrosive. Cleaning parts by the chlorinated solvent method leaves the parts absolutely dry. If they are not to be subjected to further cleaning operations, they should be sprayed with a corrosion preventive solution to protect them against rust or corrosion.

The hot section, which generally includes the combustion section and turbine sections, normally require inspections at regular intervals. The extent of disassembly of the engine to accomplish this inspection varies from different engine types. Most engines require that the combustion case be open for the inspection of the hot section. However, in performing this disassembly, numerous associated parts are readily accessible for inspection. The importance of properly supporting the engine and the parts being removed cannot be overstressed.

The alignment of components being removed and installed is also of the utmost importance. After all the inspections and repairs are made, the manufacturer's detailed assembly instructions should be followed. These instructions are important in efficient engine maintenance, and the ultimate life and performance of the engine. Extreme care must be taken during assembly to prevent dirt, dust, cotter pins, lock wire, nuts, washers, or other foreign material from entering the engine.

### MARKING MATERIALS FOR COMBUSTION SECTION PARTS

Certain materials may be used for temporary marking during assembly and disassembly. Always refer to manufacturer's information for marking parts. Layout dye (lightly applied) or chalk may be used to mark parts that are directly exposed to the engine's gas path, such as turbine blades and disks, turbine vanes, and combustion chamber liners. A wax marking pencil may be used for parts that are not directly exposed to the gas path. Do not use a wax marking pencil on a liner surface or a turbine rotor. The use of carbon alloy or metallic pencils is not recommended because of the possibility of causing intergranular corrosion attack that could result in a reduction in material strength and cracking.

## INSPECTION AND REPAIR OF COMBUSTION CHAMBERS

Inspect the combustion chambers and covers for cracks by using visible dye or fluorescent penetrant inspection method. Any cracks, nicks, or dents are usually cause for rejecting the component. Inspect the covers, noting particularly the area around the fuel drain bosses for any pits or corrosion. When repairing the combustion chamber liner, the procedures given in the appropriate engine manufacturer's overhaul instruction manual should be followed. If there is doubt that the liner is serviceable, it should be replaced.

Combustion chambers should be replaced or repaired if two cracks are progressing from a free edge so that their meeting is imminent and could allow a piece of metal that could cause turbine damage to break loose. Separate cracks in the baffle are acceptable. Cracks in the cone are rare but, at any location on this component, is cause for rejection of the liner. Cracks in the swirl vanes are cause for rejection of the liner. Loose swirl vanes may be repaired by silver brazing. Cracks in the front liner emanating from the air holes are acceptable, provided they do not exceed allowable limits. If such cracks fork or link with others, the liner must be repaired.

If two cracks originating from the same air hole are diametrically opposite, the liner is acceptable. Radial cracks extending from the interconnector and spark igniter boss are acceptable, if they do not exceed allowable limits and if such cracks do not fork or link with others. Circumferential cracks around the boss pads should be repaired prior to re-use of the liner.

Baffle cracks connecting more than two holes should be repaired. After long periods of engine operation, the external surfaces of the combustion chamber liner location pads often show signs of fretting. This is acceptable, provided no resultant cracks or perforation of the metal is apparent. Any cover or chamber inadvertently dropped on a hard surface or mishandled should be thoroughly inspected for minute cracks that may elongate over a period of time and then open, creating a hazard.

Parts may be found where localized areas have been heated to an extent to buckle small portions of the chamber. Such parts are considered acceptable if the burning of the part has not progressed into an adjacent welded area, or to such an extent as to

weaken the structure of the liner weldment. Buckling of the combustion chamber liner can be corrected by straightening the liner. Moderate buckling and associated cracks are acceptable in the row of cooling holes. More severe buckling that produces a pronounced shortening or tilting of the liner is cause for rejection. Upon completion of the repairs by welding, the liner should be restored as closely as possible to its original shape.

## FUEL NOZZLE AND SUPPORT ASSEMBLIES

Clean all carbon deposits from the nozzles by washing with a cleaning fluid approved by the engine manufacturer, and remove the softened deposits with a soft bristle brush. It is desirable to have filtered air passing through the nozzle during the cleaning operation to carry away deposits as they are loosened. Make sure all parts are clean. Dry the assemblies with clean, filtered air. Because the spray characteristics of the nozzle may become impaired, no attempt should be made to clean the nozzles by scraping with a hard implement or by rubbing with a wire brush. Inspect each component part of the fuel nozzle assembly for nicks and burrs. Many fuel nozzles can be checked by flowing fluid through the nozzle under pressure and closely checking the flow pattern coming for the nozzle.

## TURBINE SECTION

### TURBINE DISK INSPECTION

The inspection for cracks is very important because cracks are not normally allowed. Crack detection, when dealing with the turbine disk and blades is mostly visual, although structural inspection techniques can be used such as penetrant methods and others to aid in the inspection. Cracks on the disk necessitate the rejection of the disk and replacement of the turbine rotor. Slight pitting caused by the impingement of foreign matter may be blended by stoning and polishing.

### TURBINE BLADE INSPECTION

Turbine blades are usually inspected and cleaned in the same manner as compressor blades. However, because of the extreme heat under which the turbine blades operate, they are more susceptible to damage. Using a strong light and a magnifying glass, inspect the turbine blades for stress rupture cracks and deformation of the leading edge. (*Figures 21-13 and 21-14*)

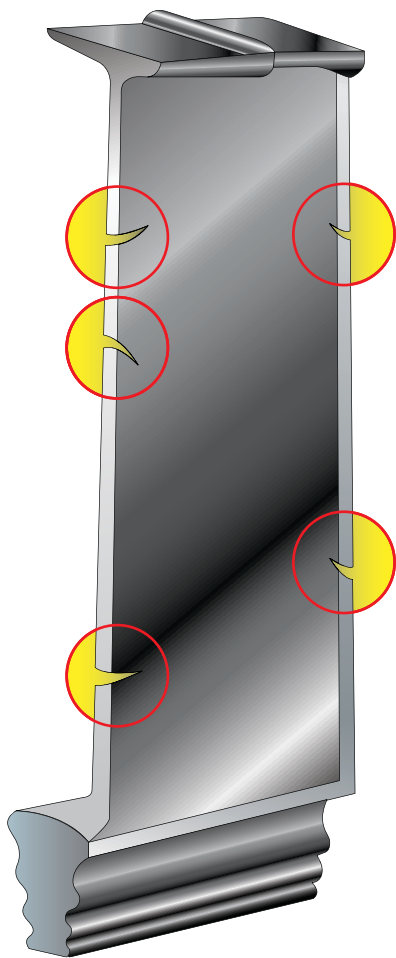

Figure 21-13. Turbine blade stress rupture cracks.

Stress rupture cracks usually appear as minute hairline cracks on or across the leading or trailing edge at a right angle to the edge length. Visible cracks may range in length from one-sixteenth inch upward. Deformation caused by over-temperature may appear as waviness and/or areas of varying airfoil thickness along the leading edge. The leading edge must be straight and of uniform thickness along its entire length, except for areas repaired by blending.

Do not confuse stress rupture cracks or deformation of the leading edge with foreign material impingement damage or with blending repairs to the blade. When any stress rupture cracks or deformation of the leading edges of the first-stage turbine blades are found, an over-temperature condition must be suspected. Check the individual blades for stretch and the turbine disk for hardness and stretch. When blades are removed for a detailed inspection, number each blade prior to removal.

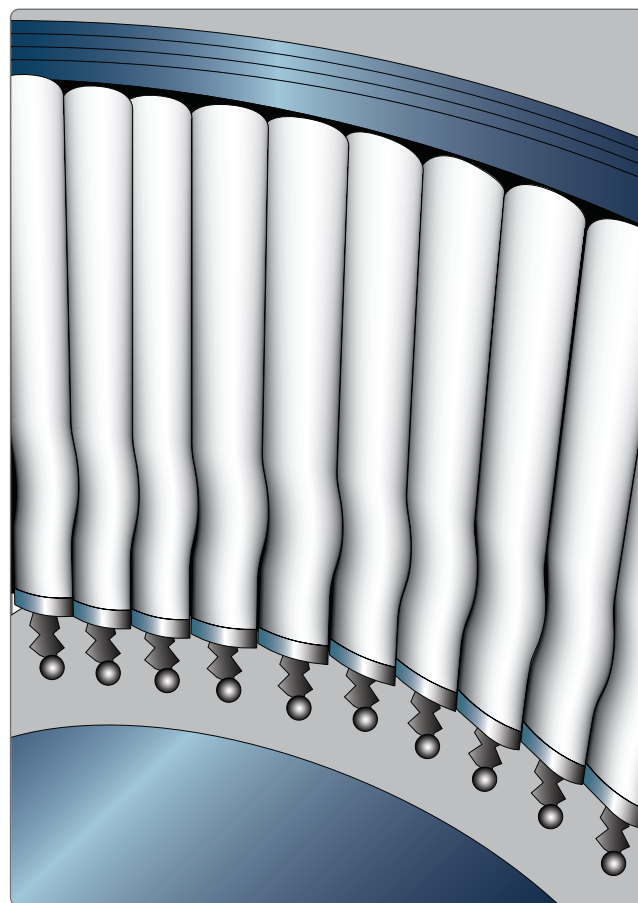

Figure 21-14. Turbine blade waviness.

The turbine blade outer shroud should be inspected for air seal wear. If shroud wear is found, measure the thickness of the shroud at the worn area. Use a micrometer or another suitable and accurate measuring device that ensures a good reading in the bottom of the comparatively narrow wear groove. If the remaining radial thickness of the shroud is less than that specified, the stretched blade must be replaced. Typical blade inspection requirements are indicated in *Figure 21-15*.

Blade tip curling within a one-half inch square area on the leading edge of the blade tip is usually acceptable if the curling is not sharp. Curling is acceptable on the trailing edge if it does not extend beyond the allowable area. Any sharp bends that may result in cracking or a piece breaking out of the turbine blade is cause for rejection, even though the curl may be within the allowable limits. Each turbine blade should be inspected for cracks.



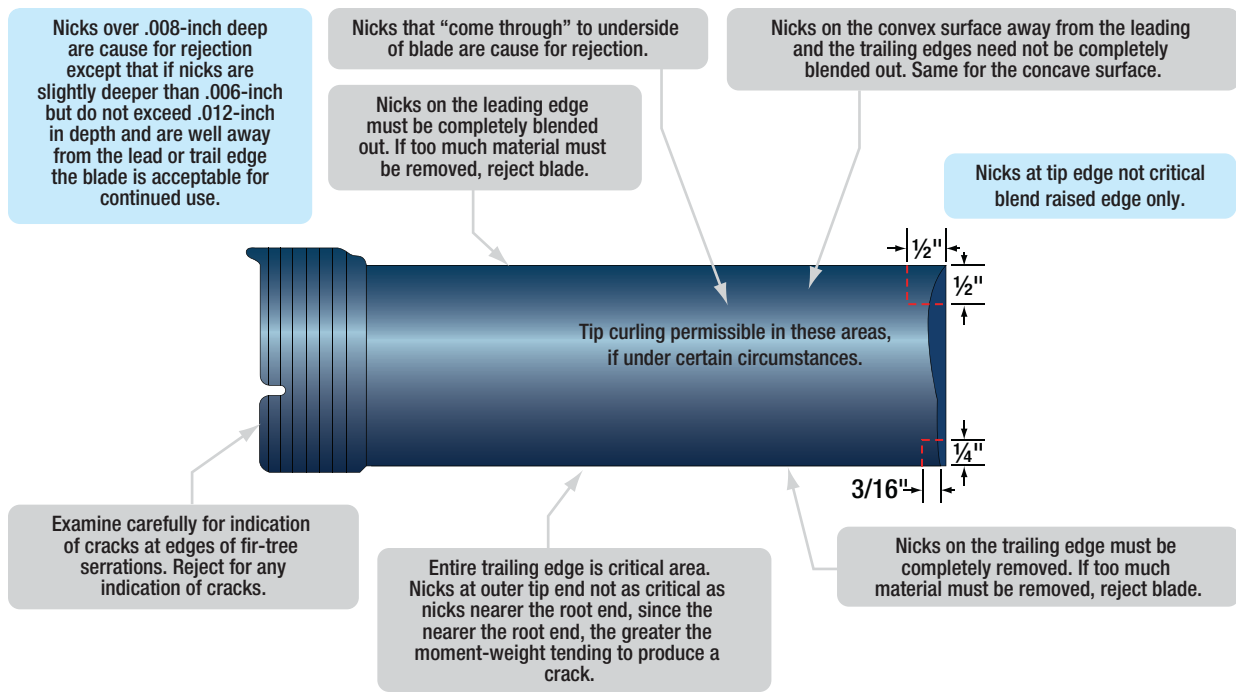

Figure 21-15. Typical turbine blade inspection.

## TURBINE BLADE REPLACEMENT PROCEDURE

Turbine blades are generally replaceable, subject to moment weight limitations. These limitations are contained in the engine manufacturer's applicable technical instructions. If visual inspection of the turbine assembly discloses several broken, cracked, or eroded blades, replacing the entire turbine assembly may be more economical than replacing the damaged blades. (Figure 21-16)

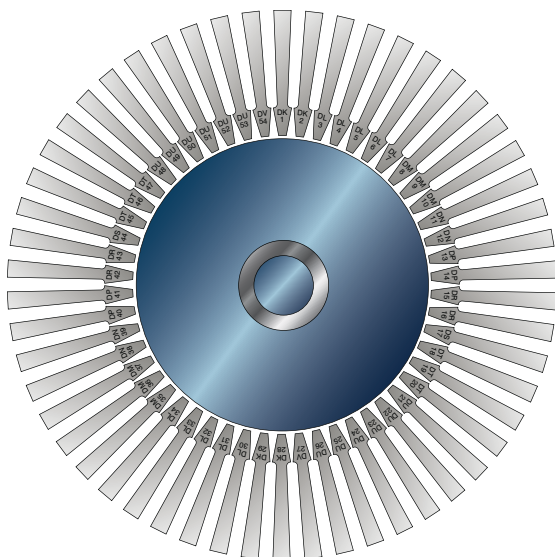

Figure 21-16. Typical turbine rotor blade moment-weight distribution.

In the initial buildup of the turbine, a complete set of 54 blades made in coded pairs (two blades having the same code letters) is laid out on a bench in the order of diminishing moment-weight. The code letters, indicating the moment weight balance in ounces, are marked on the rear face of the fir-tree section of the blade (viewing the blade as installed at final assembly of the engine). The pair of blades having the heaviest moment-weight is numbered 1 and 28; the next heaviest pair of blades is numbered 2 and 29; the third heaviest pair is numbered 3 and 30. This is continued until all the blades have been numbered. Mark a number 1 on the face of the hub on the turbine disk. The number 1 blade is then installed adjacent to the number 1 on the disk. (Figure 21-17)

The remaining blades are then installed consecutively in a clockwise direction, viewed from the rear face of the turbine disk. If there are several pairs of blades having the same code letters, they are installed consecutively before going to the next code letters. If a blade requires replacement, the diametrically opposite blade must also be replaced. Computer programs generally determine the location for turbine blades for turbine wheels on modern engines.

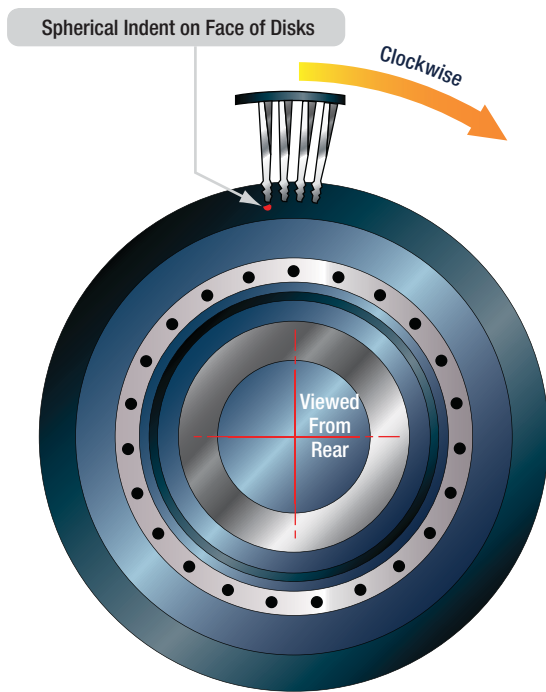

Figure 21-17. Turbine blade installation.

### TURBINE NOZZLE INLET GUIDE VANE INSPECTION

After removing the required components, the first stage turbine blades and turbine nozzle vanes are accessible for inspection. The blade limits specified in the engine manufacturer's overhaul and service instruction manual should be adhered to. *Figure 21-18* shows where cracks usually occur on a turbine nozzle assembly. Slight nicks and dents are permissible if the depth of damage is within limits. Inspect the nozzle vanes for nicks or cracks. Small nicks are not cause for vane rejection, provided such nicks blend out smoothly.

Inspect the nozzle vane supports for defects caused by the impingement of foreign particles. Use a stone to blend any doubtful nicks to a smooth radius. Like turbine blades, it is possible to replace a maximum number of turbine nozzle vanes in some engines. If more than the maximum vanes are damaged, a new turbine nozzle vane assembly must be installed. With the tailpipe (exhaust nozzle) removed, the rear turbine stage can be inspected for any cracks or evidence of blade stretch. Additional nozzle stages can also be inspected with a strong light by looking through the rear-stage turbine.

### CLEARANCES

Checking the clearances is one of the procedures in the maintenance of the turbine section of a turbine engine. The manufacturer's service and overhaul manual gives the procedures and tolerances for checking the turbine. Turbine clearances being measured at various locations are shown in *Figures 21-19 and 21-20*. To obtain accurate readings, special tools provided by each manufacturer must be used as described in the service instructions for specific engines.

### EXHAUST SECTION

The exhaust section of the turbine engine is susceptible to heat cracking. This section must be thoroughly inspected along with the inspection of the combustion section and turbine section of the engine. Inspect the exhaust cone and exhaust nozzle for cracks, warping, buckling, or hotspots. Hotspots on the tail cone are a good indication of a malfunctioning fuel nozzle or combustion chamber.

The inspection and repair procedures for the hot section of any one gas turbine engine share similarities to those of other gas turbine engines. One usual difference is the nomenclature applied to the various parts of the hot section by the different manufacturers. Other differences include the manner of disassembly, the tooling necessary, and the repair methods and limits.

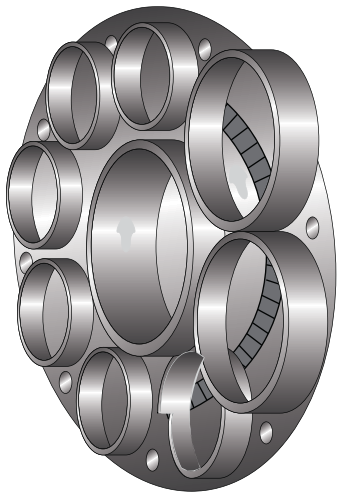

Turbine Nozzle Assembly

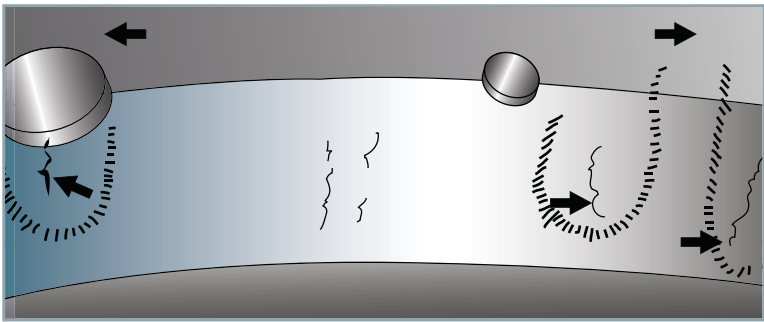

Turbine Nozzle Assembly At Junction Of Combustion Chamber Outlet Duct And Turbine Nozzle Outer Case

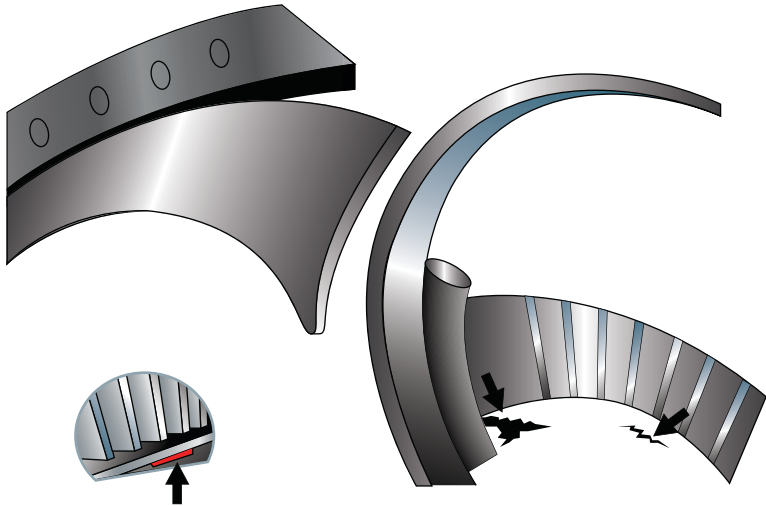
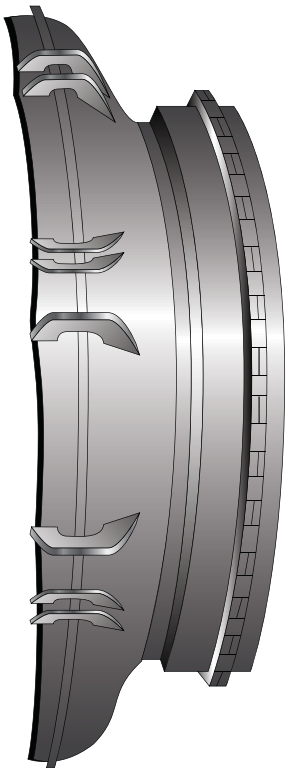

Cracked Area Along Spot Weld Line On Inner Duct

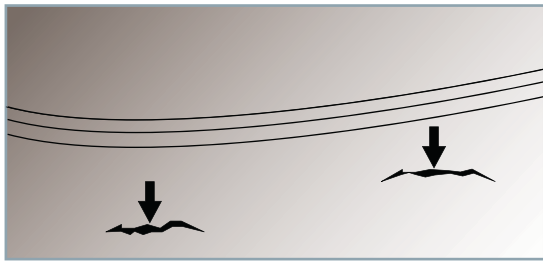

Spot Weld Cracks On Inner Duct

Figure 21-18. Turbine nozzle assembly defects.

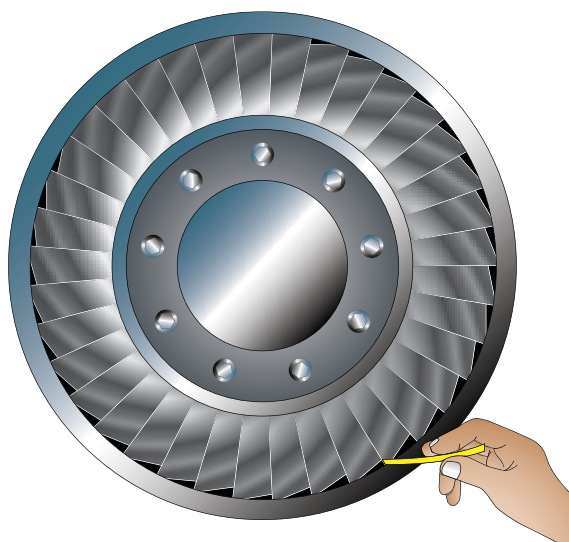

Figure 21-19. Measuring the turbine blades to shroud (tip) clearances.

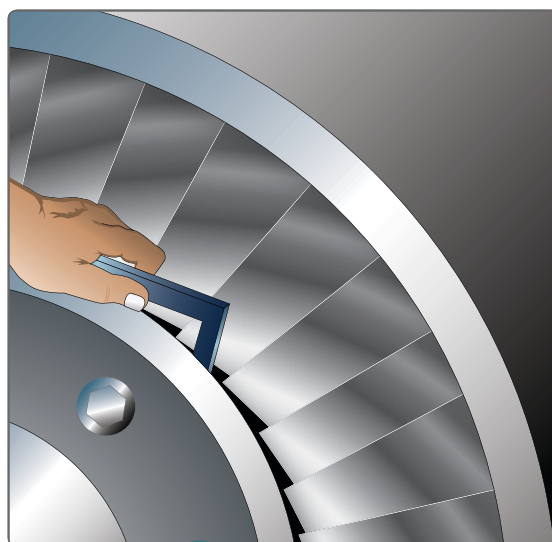

Figure 21-20. Measuring turbine wheel to exhaust cone clearance.

## TURBINE ENGINE ACCESSORIES

Turbine engine accessories should be inspected and maintained in accordance with the engine or aircraft manufacturer's maintenance manual. Carefully follow

all instructions for proper servicing. Overhaul of turbine engine accessories is typically performed at an overhaul shop per the component manufacturer's specification.

## COMPRESSOR WASHING AND CLEANING

The gradual accumulation of dirt and contaminants on the rotor and stator blades of a compressor will change the shape of and thus reduce the efficiency of each blade affected. Engine performance is thereby adversely affected. All sorts of airborne contaminants pass through the engine. They could be dust from the airport taxiways, airborne pollution such as soot or smoke particles, salt or chemical emissions from industry. These contaminants build up on the internal surfaces of an engine over a period of time. Much of this build-up can be removed with a compressor wash.

During a compressor wash, the entire engine gas path is washed with water or a mixture of water and cleaning solution as recommended by the engine manufacturer. Since the front of the engine, the compressor, is where contaminants enter the engine, it is the compressor that benefits most from the wash. The procedures for washing engines vary with manufacturers, engine types and wash solutions. Generally, the engine is rotated with the starter and the wash solution is sprayed into the first stage compressor blades. A soaking period may be specified and the procedure is repeated. Water used

in washing should be relatively free from solids and salt. Only specified cleaning agent should be used.

Grit blasting of turbine engines is another procedure designed to clean the compressor. Walnut shell grit or apricot pit grit is introduced into the operating engine at specified power settings. This abrasive substance more effectively cleans the compressor, however the grit is burned in the combustion section leaving the turbine untreated. Extreme caution must be exercised when working near an operating turbine engine. Do not stand directly in the intake air path. Severe injury and death can result from being ingested into a turbine engine.

---

## FOREIGN OBJECT DAMAGE (FOD)

Foreign object damage, or FOD is an ongoing issue for the safe operation of aircraft engines, especially turbine engines that have intake airflow powerful enough to lift objects of the ramp and feed them into the engine. As has been mentioned many times throughout this module, ingestion of foreign matter into the intake of a turbine engine causes damage or degrades performance, ultimately leading to shortened engine life. All technicians must be vigilant for any foreign objects on hangar floor, ramp surfaces and the like. Ramp and run-up areas must be regularly swept to be kept clear of foreign objects.

Nuts, bolts, trash, safety wire, rivets, rags - should never be cast upon the ground when working around aircraft. When it is inevitable such as during extensive maintenance work, a thorough clean-up including sweeping should occur before any engines are operated.

All FOD is not necessarily caused by small objects cast away or overlooked on the airport apron. Maintenance tools are a very big FOD threat. All technicians must develop good working practices which include accounting for all tools before a job is considered complete and the aircraft safe for operation. A neatly organized toolbox and a check that all tools have been returned to their place within it after working is highly recommended.

*Question:* 21-1

During a typical turbine engine start, it is necessary to monitor the tachometer, the oil pressure, and the \_\_\_\_\_.

*Question:* 21-5

Accumulation of dirt on the compressor blades reduces the \_\_\_\_\_ of the blades with resultant deterioration in engine performance.

*Question:* 21-2

When computing takeoff thrust, gas turbine engines are particularly sensitive to ambient air \_\_\_\_\_ and \_\_\_\_\_ values at the compressor inlet.

*Question:* 21-6

The purpose of \_\_\_\_\_ with crocus cloth, fine files, and stones is to minimize stresses that concentrate at dents, scratches, or cracks in compressor blades.

*Question:* 21-3

On a turboprop engine, torque meter pressure is approximately proportional to the \_\_\_\_\_ and, thus, is used as a measure of engine performance.

*Question:* 21-7

One of the most frequent discrepancies detected while inspecting the hot section of a turbine engine is \_\_\_\_\_.

*Question:* 21-4

Microscopic particles of metallic elements in engine oil are called \_\_\_\_\_.

*Question:* 21-8

The hot section, which generally includes the \_\_\_\_\_ section and \_\_\_\_\_ sections, normally require inspections at regular intervals.

## ANSWERS

*Answer:* 21-1  
exhaust gas temperature.

*Answer:* 21-5  
aerodynamic efficiency.

*Answer:* 21-2  
temperature.  
pressure.

*Answer:* 21-6  
blending.

*Answer:* 21-3  
total power output.

*Answer:* 21-7  
cracking.

*Answer:* 21-4  
wear metals.

*Answer:* 21-8  
combustion.  
turbine.

**Question:** 21-9

Inspection of a turbine engine combustion chamber and covers for cracks can be done by using visible dye or \_\_\_\_\_ inspection method.

**Question:** 21-12

Similar to the procedure for turbine blades, what must be done if more than the maximum number of turbine nozzle vanes are damaged?

**Question:** 21-10

Because of the extreme heat under which the \_\_\_\_\_ operate, they are more susceptible to damage than compressor blades.

**Question:** 21-13

\_\_\_\_\_ on the tail cone are a good indication of a malfunctioning fuel nozzle or combustion chamber.

**Question:** 21-11

Turbine blades are weighed and installed in \_\_\_\_\_.

**Question:** 21-14

Why is FOD (foreign object damage) a greater problem for turbine engines than it is for reciprocating engines?



## ANSWERS

*Answer:* 21-09  
fluorescent penetrant.

*Answer:* 21-12  
A new turbine nozzle vane assembly must be installed.

*Answer:* 21-10  
turbine blades.

*Answer:* 21-13  
Hotspots.

*Answer:* 21-11  
pairs.

*Answer:* 21-14  
Intake airflow is more powerful and can lift objects off the ramp and feed them into the engine.



PART-66 SYLLABUS **LEVELS**  
 CERTIFICATION CATEGORY → **A1** **B1**

**Sub-Module 22**  
**ENGINE STORAGE AND PRESERVATION**  
 Knowledge Requirements

*15.22 - Engine Storage and Preservation*

Preservation and de preservation for the engine and accessories/systems.

	A1	B1
	-	2

**Level 2**

A general knowledge of the theoretical and practical aspects of the subject and an ability to apply that knowledge.

*Objectives:*

- (a) The applicant should be able to understand the theoretical fundamentals of the subject.
- (b) The applicant should be able to give a general description of the subject using, as appropriate, typical examples.
- (c) The applicant should be able to use mathematical formula in conjunction with physical laws describing the subject.
- (d) The applicant should be able to read and understand sketches, drawings and schematics describing the subject.
- (e) The applicant should be able to apply his knowledge in a practical manner using detailed procedures.

---

## ENGINE STORAGE AND PRESERVATION

The following discussion includes some information on engine storage and preservation of reciprocating engines as well as turbine engines. Also note that each manufacturer's instructions for storage procedures and materials used to preserve and must be followed. The information is general guidance only.

An engine awaiting overhaul or return to service after overhaul must be given careful attention. It does not receive the daily care and attention necessary to detect and correct early stages of corrosion. For this reason, some definite action must be taken to prevent corrosion from affecting the engine. Engines that are not flown regularly may not achieve normal service life because of corrosion. The normal combustion process creates moisture and corrosive by-products that attack the unprotected surfaces. Engines under favorable atmospheric conditions can remain inactive for several weeks without evidence of damage by corrosion. This is the best-case scenario.

Aircraft that operate close to oceans, lakes, rivers, and humid regions have a greater need for engine preservation than engines operated in dry low humid areas. Corrosion formation in engines located in areas of high susceptibility will occur in a matter of days.

### CORROSION-PREVENTIVE MATERIALS

An engine in service is in a sense self-purging of moisture, since the heat of combustion evaporates the moisture in and around the engine, and the lubricating oil circulated through the engine temporarily forms a protective coating on the metal it contacts. If the operation of an engine in service is limited or suspended for a period of time, the engine is preserved to a varying extent, depending upon how long it is to be inoperative. There are three types of engine storage: active engine, temporary, and indefinite. An engine in active storage is defined as having at least one continuous hour of operation with an oil temperature of at least 165 °F to 200 °F and storage time not to exceed 30 days. Temporary storage describes an aircraft and engine that is not flown for 30 to 90 days, and indefinite storage is for an aircraft not to be flown for over 90 days or is removed from the aircraft for extended time.

### CORROSION-PREVENTIVE COMPOUNDS

The preservation materials discussed are used for all types of engine storage. Corrosion- preventive compounds are petroleum-based products that form a wax-like film over the metal to which they are applied. Several types of corrosion preventive compounds are manufactured according to different specifications to fit the various aviation needs. The type mixed with engine oil to form a corrosion-preventive mixture is a relatively light compound that readily blends with engine oil when the mixture is heated to the proper temperature.

The light mixture is available in three forms: MIL-C-6529C type I, type II, or type III. Type I is a concentrate and must be blended with three parts of MIL-L-22851 or MIL-L-6082C (SAE J1966) grade 1100 oil to one part of concentrate. Type II is a ready- mixed material with MIL-L-22851 or grade 1100 oil and does not require dilution. Type III is a ready-mixed material with grade 1010 oil for use in turbine engines only. The light mixture is intended for use when a preserved engine is to remain inactive for less than 30 days. It is also used to spray cylinders and other designated areas.

The desired proportions of lubricating oil, and either heavy or light corrosion-preventive compound, must not be obtained by adding the compound to the oil already in the engine. The mixture must be prepared separately before applying to the engine or placing in an oil tank.

A heavy compound is used for the dip treating of metal parts and surfaces. It must be heated to a high temperature to be sufficiently liquid to effectively coat the objects to be preserved. A commercial solvent, or kerosene spray, is used to remove corrosion-preventive compounds from the engine when they are being prepared for return to service. Although corrosion-preventive compounds act as an insulator from moisture, in the presence of excessive moisture, they eventually break down and corrosion begins. Also, the compounds eventually dry because their oil base gradually evaporates. This allows moisture to contact the engine's metal and aids in corroding it. Therefore, when an engine is stored in a shipping case or container, some dehydrating (moisture removing) agent must be used to remove the moisture from the air in and around the engine.

## DEHYDRATING AGENTS

There are a number of substances (referred to as desiccants) that can absorb moisture from the atmosphere in sufficient quantities to be useful as dehydrators. One of these is silica gel. This gel is an ideal dehydrating agent since it does not dissolve when saturated. As a corrosion preventive, bags of silica gel are placed around and inside various accessible parts of a stored engine.

## ENGINE SHIPPING CONTAINERS

For protection, engines are sealed in plastic or foil envelopes and can be packed in a wooden shipping case or in pressurized metal containers. The engine is lowered into the shipping container so that the mounting plate can be bolted into position. The protective envelope is attached directly to the base of the shipping case. Then, the engine is lowered vertically onto the base and bolted directly to it. A carburetor not mounted on its reciprocating engine (or no provision is made to seal it in a small container to be placed inside the shipping case) can, in some cases, be fastened to a specially constructed platform bolted to the engine.

Before the protective envelope is sealed, silica gel should be placed around the engine to dehydrate the air sealed into the envelope. The amount of silica gel used is determined by the size of the engine. The protective envelope is then carefully gathered around the engine and partially sealed, leaving an opening at one end from which as much air as possible is exhausted. A vacuum applied to the container is very useful for this purpose and is also an aid in detecting any leaks in the envelope. The envelope is then completely sealed, usually by pressing the edges together and fusing them with heat.

Before lowering the shipping case cover over the engine, a quick inventory should be made. Be sure the humidity indicator card is placed so that it can be seen through the inspection window and that everything required is enclosed in the container. While lowering the wooden shipping case cover into position, be careful that it does not twist and tear the protective envelope. Secure the cover and stencil or mark the date of preservation on the case. Also, indicate whether the engine is repairable or serviceable.

There are several types of shipping containers in use. (*Figure 22-1*) Another type allows horizontal installation of an engine, thus eliminating the need for an extra hoist. The engine is simply lowered onto the base portion of the container and secured. Then, silica gel bags are packed into the container, usually in a special section. The amount of silica gel required in a metal container is generally greater than that needed in a wooden shipping case, since the volume of air in the metal container is much greater than that in the protective envelope installed around an engine in a wooden shipping case. Also, in the metal container the silica gel bags must dehydrate the interior of the engine, since ventilatory plugs are normally installed in the engine openings in place of dehydrator plugs.

All records of the engine should be enclosed inside the shipping container or on the outside for accessibility. A humidity indicator should be fastened inside the containers with an inspection window provided. Then, the rubber seal between the base and the top of the container must be carefully inspected. This seal is usually suitable for re-use several times. After the top of the container has been lowered into position and fastened to the base of the container, dehydrated air at approximately 5 pounds per square inch (psi) pressure is forced into the container. The container should be checked for leaks by occasional rechecks of the air pressure, since radical changes in temperature affect the air pressure in the container.

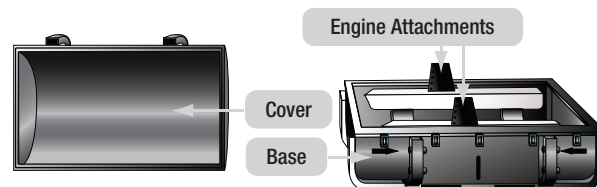

Figure 22-1. Turbine engine shipping container.

---

## INSPECTION OF STORED ENGINES

Most maintenance shops provide a scheduled inspection system for engines in storage. Normally, the humidity indicators on engines stored in shipping cases are inspected every 30 days. When the protective envelope must be opened to inspect the humidity indicator, the inspection period may be extended to once every 90 days, if local conditions permit. The humidity indicator of a metal container is inspected every 180 days under normal conditions.

If the humidity indicator in a wooden shipping case shows by its color that more than 30 percent relative

humidity is present in the air around the engine, all desiccants should be replaced. If more than half the dehydrator plugs installed in the spark plug holes indicate the presence of excessive moisture, the interior of the cylinders should be resprayed. If the humidity indicator in a metal container gives a safe blue indication, but air pressure has dropped below 1 psi, the container needs only to be brought to the proper pressure with dehydrated air. However, if the humidity indicator shows an unsafe (pink) condition, the engine should be represerved.

---

## PRESERVATION AND DEPRESERVATION OF GAS TURBINE ENGINES

The procedures for preserving and depreserving gas turbine engines vary depending upon the length of inactivity, the type of preservative used, and whether or not the engine may be rotated during the inactive period. Much of the general information on corrosion control presented in the sections above is applicable to gas turbine engines. However, the requirements for the types of preservatives and their use are normally different. The lubrication system is usually drained and

may or may not be flushed with preservative oil. The engine fuel system is generally filled with preservative oil, including the fuel control. Before the engine can be returned to service, the preservative oil must be completely flushed from the fuel system by motoring the engine and bleeding the fuel system. Always follow the manufacturer's instructions when performing any preservation or depreservation of gas turbine engines.

---

## PRESERVATION AND DEPRESERVATION OF ENGINE ACCESSORIES

The preservation and depreservation of engine accessories is done independently of the engine. Follow the component manufacturer's instructions on how to store components safely for long period of time. As with the engine, the basic concern is the threat of corrosion while in storage.

**Question: 22-1**

There are three types of engine storage: active engine, temporary, and \_\_\_\_\_.

**Question: 22-4**

Why are corrosion prevention compounds not necessarily required for an engine in frequent use?

**Question: 22-2**

A substance that can absorb moisture from the atmosphere in sufficient quantity to be useful as dehydrators for stored engines is known as a \_\_\_\_\_.

**Question: 22-5**

At what point should desiccants within a storage container be replaced?

**Question: 22-3**

As with the engine, the basic concern and reason for the preservation and depreservation of engine components is the threat of \_\_\_\_\_ when not operated for long periods of time.

## ANSWERS

*Answer: 22-1*  
indefinite.

*Answer: 22-4*  
Heat of operation purges moisture; circulating oil provides a moisture barrier.

*Answer: 22-2*  
desiccant (i.e. silica gel).

*Answer: 22-5*  
If humidity levels within the container exceed 30%.

*Answer: 22-3*  
corrosion.

AC	/	Alternating Current
ACM	/	Air Cycle Machine
ADU	/	Auxiliary Drive Unit
AIMS	/	Aircraft In-flight Monitoring System
APCE	/	Auxiliary Power Control Unit
APU	/	Auxiliary Power Unit
AVGAS	/	Aviation Gasoline
BITE	/	Built In Test Equipment
BTU	/	British Thermal Unit
CMC	/	Central Maintenance Computer
CRT	/	Cathode Ray Tube
CSD	/	Constant Speed Drive
DC	/	Direct Current
DOT	/	Department of Transportation (United States)
ECAM	/	Electronic Centralized Aircraft Monitor
ECU	/	Electronic Control Unit
EEC	/	Electronic Engine Control
EFCU	/	Electronic Fuel Control Unit
EGT	/	Exhaust Gas Temperature
EICAS	/	Engine Indicating and Crew Alert System
EMF	/	Electromagnetic Field
EPR	/	Engine Pressure Ratio
ETOPS	/	Extended Twin Operational Performance
FAA	/	Federal Aviation Administration
FADEC	/	Full Authority Digital Electronic Control
FCU	/	Fuel Control Unit
FMU	/	Fuel Metering Unit
FOC	/	Fuel Oil Cooler
FOD	/	Foreign Object Damage
GPU	/	Ground Power Unit
HRD	/	High Rate of Discharge
IGV	/	Inlet Guide Vanes
IR	/	Infrared
KVA	/	Kilovolt Ampere
LRU	/	Line Replaceable Unit
N1	/	Low Pressure Compressor Speed
N2	/	High Pressure Compressor Speed
NOX	/	Nitrogen Oxides
OAT	/	Outside Air Temperature
OEM	/	Original Equipment Manufacturer
PLA	/	Power Lever Angle
PMA	/	Permanent Magnet Alternator
PMG	/	Permanent Magnet Generator
PPM	/	Parts per Million
Pt2	/	Pressure Engine Inlet
Pt7	/	Pressure Turbine Exhaust



RPM	/	Revolutions Per Minute
SHP	/	Shaft Horse Power
TAPS	/	Twin Annular Pre-Mixing Swirler
TAT	/	Total Air Temperature
TBO	/	Time Between Overhaul
TGT	/	Turbine Gas Temperature
TIT	/	Turbine Inlet Temperature
TOT	/	Turbine Outlet Temperature
TRU	/	Transformer Rectifier Unit
V1	/	Inlet Velocity
V2	/	Exhaust Velocity
VCR	/	Viscosity Compensated Restrictor
VIGV	/	Variable Inlet Guide Vane
VSCF	/	Variable Speed Constant Frequency
VSV	/	Variable Stator Vane
Wf/P3	/	Fuel Flow / Compressor Discharge Pressure

## A

Acceleration .....	1.8
Accessory Section.....	10.13
Accessory Zone Cooling.....	12.2
Acoustic Panels .....	19.3
After Burning/Thrust Augmentation .....	15.2
Airblast Nozzles.....	11.13
Air Entrance .....	3.2
Air Oil Coolers .....	10.8
Air Systems .....	12.2
Air Turbine Starters .....	13.5
Air Turbine Troubleshooting Guide.....	13.9
Ambient Conditions .....	21.3
Anti-Ice Control Systems .....	12.3
APU Control.....	18.6
APU Fire Detection and Extinguishing System .....	20.17
APU Fire Warning .....	20.17
Automatic Self-Interrogation.....	20.7
Auxiliary Power Units (APUs) .....	18.2
Axial-Flow Compressor.....	4.4

## B

Bearings and Seals .....	8.2
Bellmouth Compressor Inlets .....	3.5
Bernoulli's principle .....	1.4
Blending and Replacement .....	21.11
Boeing 777 Aircraft Fire Detection and Extinguishing System .....	20.12
Borescope .....	21.8
Boyle's & Charles' Law .....	1.5
Breather Pressurizing System .....	10.11
Breather Subsystems .....	10.12
Bypass Ratio.....	1.12

## C

Capacitor Discharge Exciter Unit.....	13.12
Cartridge Pneumatic Starters .....	13.2
Causes of Blade Damage.....	21.10
Centrifugal-Flow Compressors .....	4.2
Checking Takeoff Thrust .....	21.2
Check System Operation .....	13.14
Clearances .....	21.17
Combination Fire and Overheat Warning .....	20.6

Combustion Drain Valves.....	11.15
Combustion Section.....	5.2
Combustion Section Inspection.....	21.12
Compactness .....	1.11
Components .....	13.15
Components .....	20.2
Compressor Inlet Screens .....	3.4
Compressor Section .....	4.2
Compressor Section .....	21.8
Compressor Stall and Surge.....	4.7
Compressor Types and Applications.....	4.2
Compressor Washing and Cleaning .....	21.19
Construction .....	18.2
Containers.....	20.10
Continuous Fault Monitoring.....	20.12
Continuous-Loop Detector Systems.....	20.4
Control Cables and Rods .....	19.4
Control Systems .....	17.2
Convergent-Divergent Exhaust Nozzle .....	7.5
Convergent Exhaust Nozzle .....	7.5
Corrosion-Preventive Compounds .....	22.2
Corrosion-Preventive Materials.....	22.2
Couplings and Drive Systems .....	17.2
Cowling.....	19.3
Crew Control and Monitoring.....	18.7

## D

Dehydrating Agents.....	22.3
Deoiler .....	10.9
Diffuser .....	4.6
Discharge Indicators .....	20.11
Divided-Entrance Duct .....	3.3
Drains.....	19.14
Dual-Loop Systems .....	20.7
Duplex Fuel Nozzle .....	11.13
Durability and Reliability .....	1.11

## E

Electric Starting Systems and Starter Generator Starting Systems.....	13.3
Energy.....	1.2
Engine Checks .....	21.2
Engine Fire Detection Systems .....	20.3
Engine Fire Extinguishing System.....	20.9

# INDEX

Engine Fire Operation.....	20.16	Fuel-Flow Indicator .....	14.6
Engine Fire Switches .....	20.15	Fuel Heater .....	11.11
Engine Fuel System Components.....	11.10	Fuel Identification .....	9.4
Engine Indicating Systems .....	14.2	Fuel Lines.....	19.4
Engine Monitoring and Ground Operation.....	21.2	Fuel Nozzle and Support Assemblies .....	21.14
Engine Noise Suppression .....	7.8	Fuel Oil Coolers.....	10.9
Engine Oil Pressure Indicator .....	14.6	Fuel Pressurizing and Dump Valves .....	11.14
Engine Oil Temperature Indicator .....	14.6	Fuel Quantity Indicating Units.....	11.15
Engine Performance.....	2.2	Fuel Spray Nozzles and Fuel Manifolds .....	11.12
Engine Pressure Ratio.....	2.7	Fuel System Operation.....	11.9
Engine Pressure Ratio (EPR)Indicator.....	14.4		
Engine Ratings .....	2.7	<b>G</b>	
Engine Shipping Containers.....	22.3	—	
Engine Shutdown .....	21.4	Gas Turbine Engine Performance .....	2.5
Engine Storage and Preservation .....	22.2	Gas Turbine Engine Starters .....	13.2
Engine Systems .....	18.4	Gear Coupled / Fixed Turbine and Free Turbine.....	16.2
Exhaust Gas Temperature Indicator (EGT) .....	14.2	General Requirements .....	1.9
Exhaust Nozzles.....	7.4	General Requirements .....	11.2
Exhaust Section .....	7.2	Ground Operation Engine Fire .....	21.2
Exhaust Section .....	21.17		
<b>F</b>		<b>H</b>	
—		—	
FADEC for an Auxiliary.....	11.5	Hoses and Pipes .....	19.4
FADEC Fuel Control Propulsion Engine.....	11.7	Hydraulic Lines .....	19.4
FADEC Fuel Control Systems.....	11.5	Hydromechanical/Electronic Fuel Control.....	11.3
Fan Balance.....	4.6	Hydromechanical Fuel Controls.....	11.3
Feeders, Connectors and Wiring Looms.....	19.12		
Fenwal Continuous-Loop System.....	20.5	<b>I</b>	
Fire Bottle Discharge.....	20.17	—	
Fire Detection.....	20.12	Igniter Plugs.....	13.13
Fire Detection Control Unit (Fire Detection Card).....	20.8	Igniter Plugs.....	13.15
Fire Extinguisher Containers .....	20.13	Ignition System Leads .....	13.15
Fire Extinguishing Agents .....	20.9	Ignition System Maintenance Safety.....	13.12
Fire Protection Systems .....	20.2	Infrared Optical Fire Protection.....	20.4
Fire Switch .....	20.11	Inlets and Accessory.....	3.2
Firewalls.....	19.2	Inspection.....	13.14
Fire Zones.....	20.8	Inspection and Cleaning.....	21.9
First Law.....	1.3	Inspection and Repair of Combustion Chambers .....	21.14
Flight Certified APUs .....	18.7	Inspection and Servicing.....	18.8
Flow Divider .....	11.14	Inspection of Stored Engines.....	22.4
Force.....	1.5	Installation .....	18.4
Force, Work, Power and Torque .....	1.5		
Foreign Object Damage (FOD) .....	21.20	<b>K</b>	
Fuel Economy .....	1.10	—	
Fuel Filters .....	11.11	Kidde Continuous-Loop System .....	20.6
		Kinetic Energy .....	1.2

## L

Lifting Points.....	19.14
Lubricants and Fuels.....	9.2
Lubrication System Breather Systems (Vents).....	10.7
Lubrication System Check Valve.....	10.8
Lubrication System Instrumentation.....	10.7
Lubrication System Thermostatic Bypass Valves.....	10.8

## M

Magnetic Chip Detectors.....	10.9
Main Fuel Pumps (Engine Driven).....	11.10
Marking Materials for Combustion Section Parts.....	21.13
Microbes.....	9.5
Motion.....	1.7
Mounts for Turbofan Engines.....	19.3

## N

Nacelle Temperature Recording.....	20.12
Newton's Laws of Motion.....	1.3

## O

Oil Jets.....	10.6
Oil Pressure Regulating Valve.....	10.5
Oil Pressure Relief Valve.....	10.6
Oil Pump.....	10.3
Oil Tank.....	10.2
Operating Flexibility.....	1.11
Optical Fire Detection Systems.....	20.4
O-Ring Seals.....	19.11
Overheat Detection.....	20.12
Over speed Safety Devices.....	16.4

## P

Pneumatic Thermal Fire Detection.....	20.4
Potential Energy.....	1.2
Power.....	1.6
Power and Weight.....	1.10
Power Augmentation Systems.....	15.2
Powerplant Installations.....	19.2
Power Unit.....	11.5

## Preservation and Depreservation of Engine

Accessories.....	22.4
Preservation and Depreservation of Gas Turbine Engines.....	22.4
Pressure Indication.....	20.10
Pressure Subsystem.....	10.11
Pressure System.....	10.10
Principle of Operation.....	20.4
Purity.....	9.4

## R

Ram Recovery.....	2.6
Reduction Gear Assembly.....	16.4
Reduction Gearing.....	17.2
Removal, Maintenance and Installation of Ignition System.....	13.15
Repair.....	13.15
Requirements for Turbine Engine Lubricants.....	9.2

## S

Scavenger Subsystem.....	10.12
Scavenge System.....	10.10
Second Law.....	1.3
Sensing Element.....	20.6
Simplex Fuel Nozzle.....	11.13
Single/Dual Loop Operation.....	20.13
Spectrometric Oil Analysis Program.....	21.6
Speed and Velocity.....	1.8
Squib.....	20.14
Starting Systems.....	13.2
Support Tube-Mounted Sensing Elements.....	20.7
System Test.....	20.7
System Test.....	20.13

## T

Tachometer.....	14.5
The Brayton Cycle.....	2.3
Thermal Discharge Indicator (Red Disk).....	20.11
Thermal Switch System.....	20.3
Thermocouple Systems.....	20.3
Third Law.....	1.4
Thrust.....	2.2
Thrust Reverser's.....	7.6

# INDEX

Thrust Vectoring .....	7.8	Typical Dry-Sump Variable Pressure Lubrication System.....	10.11
Torque .....	1.7	Typical Wear Metals and Additives.....	21.6
Torquemeter (Turboprop Engines) .....	14.4	<b>V</b>	
Troubleshooting a Starter Generator Starting System..	13.5	—	
Troubleshooting Procedures for Turboprop Engines....	21.6	Variable-Geometry Duct .....	3.4
Troubleshooting Turbine Engines .....	21.4	Vibration .....	21.6
Turbine Area Inspection .....	6.2	Vibration Monitoring.....	14.6
Turbine Blade Inspection .....	21.14	<b>W</b>	
Turbine Blade Replacement Procedure.....	21.16	—	
Turbine Disk Inspection .....	21.14	Warning Systems .....	20.12
Turbine Engine Accessories.....	21.19	Water Injection System .....	15.3
Turbine Engine Cooling .....	12.2	Work .....	1.6
Turbine Engine Emissions.....	7.10	<b>Y</b>	
Turbine Engine Fuels.....	9.3	—	
Turbine Engine Fuel Systems .....	11.2	Yellow Disk Discharge Indicator .....	20.11
Turbine Engine Fuel Types.....	9.4		
Turbine Engine Fundamentals .....	1.2		
Turbine Engine Ground Fire Protection .....	20.9		
Turbine Engine Ignition Systems .....	13.10		
Turbine Engine Inlet Systems.....	3.2		
Turbine Engine Lubrication Systems.....	10.2		
Turbine Engine Maintenance .....	21.8		
Turbine Engine Operating Principles.....	2.2		
Turbine Engine Operation.....	21.2		
Turbine Engine Types.....	1.12		
Turbine Engine Wet-Sump Lubrication System .....	10.13		
Turbine Fuel Controls.....	11.2		
Turbine Fuel Volatility.....	9.4		
Turbine Ignition System Inspection and Maintenance.	13.14		
Turbine Lubrication System Components .....	10.2		
Turbine Nozzle Inlet Guide Vane Inspection.....	21.17		
Turbine Oil Health and Safety Precautions.....	9.2		
Turbine Section.....	6.2		
Turbine Section.....	21.14		
Turbine Vibration Isolation Engine Mounts.....	19.3		
Turbofan Engine Inlet Sections.....	3.6		
Turboprop and Turboshaft Compressor Inlets .....	3.6		
Turboprop Controls .....	16.2		
Turbo-Propeller Assembly.....	16.4		
Turboprop Engines .....	16.2		
Turboprop Operation.....	21.4		
Turboshaft Engines.....	17.2		
Two-Way Check Valve.....	20.11		
Types and Construction.....	1.11		
Typical Dry-Sump Pressure Regulated Turbine Lubrication System .....	10.10		



+1 970 726 5111  
[www.actechbooks.com](http://www.actechbooks.com)

72413 US Hwy 40  
Tabernash, CO 80478-0270  
USA

ISBN 978-0989754767



9 780989 754767