

Module

17A

FOR LEVEL B-1 CERTIFICATION

PROPELLER

Aviation Maintenance Technician
Certification Series

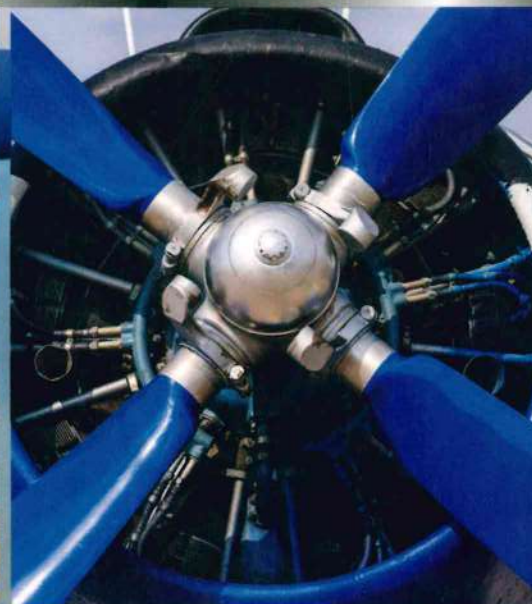

- Fundamentals
- Propeller Construction
- Propeller Pitch Control
- Propeller Synchronizing
- Propeller Ice Protection
- Propeller Maintenance
- Propeller Storage and Preservation



MODULE 17A

FOR B1 LEVEL CERTIFICATION

PROPELLER

Aviation Maintenance Technician Certification Series



AIRCRAFT
TECHNICAL
Book Company

72413 U.S. Hwy 40
Tabernash, CO 80478-0270 USA

www.actechbooks.com

+1 970 726-5111

+1 970 726-5115 FAX



AVIATION MAINTENANCE TECHNICIAN CERTIFICATION SERIES

Principal Author: Charles L. Rodriguez

Layout & Design: Shellie L. Hall

Copyright © 2016 — Aircraft Technical Book Company. All Rights Reserved.

No part of this publication may be reproduced, stored in a retrieval system, transmitted in any form or by any means, electronic, mechanical, photocopying, recording or otherwise, without the prior written permission of the publisher.

To order books or for Customer Service, please call +1 970 726-5111.

www.actechbooks.com

Printed in the United States of America

ISBN 978-1-941144-36-7



CONTENTS

SUB-MODULE 04

PROPELLER SYNCHRONIZING

| | |
|--|-----|
| Knowledge Requirements | 4.1 |
| Propeller Synchronization Systems | 4.2 |
| Propeller Synchronization | 4.2 |
| FADEC Systems | 4.3 |
| Propeller Synchrophasing | 4.3 |
| Twin Engine Synchronizer/Synchrophaser Testing on Piston-Powered Aircraft | 4.4 |
| SAAB Synchronizer/Synchrophaser on Turboprop System | 4.5 |
| Operation | 4.5 |
| System Testing | 4.5 |
| Active Noise and Vibration Suppression System | 4.6 |
| Questions | 4.7 |
| Answers | 4.8 |

SUB-MODULE 05

PROPELLER ICE PROTECTION

| | |
|---|------|
| Knowledge Requirements | 5.1 |
| Propeller Ice Protection Systems | 5.2 |
| Anti-icing Systems..... | 5.2 |
| De-icing Systems | 5.4 |
| Inspection, Maintenance, and Testing | |
| Anti-Icing System | 5.5 |
| Inspection, Maintenance, and Testing the Electric De-icing System..... | 5.7 |
| Brush Block Assembly | 5.7 |
| Sequencing Timer Assembly | 5.8 |
| Resistance Checks..... | 5.8 |
| Replacing Overshoes..... | 5.8 |
| Questions | 5.11 |
| Answers | 5.12 |

SUB-MODULE 06

PROPELLER MAINTENANCE

| | |
|--|-----|
| Knowledge Requirements | 6.1 |
| Propeller Inspection and Maintenance | 6.2 |
| Visual Inspection | 6.2 |
| Tactile Inspection | 6.2 |
| Blade Assessment..... | 6.3 |
| Wood Propeller Inspection | 6.4 |
| Metal Propeller Inspection | 6.4 |
| Dye Penetrants, Etching, and Chromic Acid | 6.4 |
| Eddy Current | 6.5 |
| Ultra Sound..... | 6.5 |
| Magnetic Particles | 6.5 |

| | |
|---|------|
| Composite Propeller Inspection | 6.6 |
| Coin Tap | 6.6 |
| Blade Tracking..... | 6.6 |
| Checking and Adjusting Propeller Blade Angles | 6.7 |
| Universal Propeller Protractor | 6.7 |
| Propeller Vibration | 6.8 |
| Propeller Balancing..... | 6.9 |
| Static Balancing | 6.9 |
| Dynamic Balancing | 6.10 |
| Balancing Procedure | 6.11 |
| Vibration Spectrum Survey | 6.14 |
| Propeller Lubrication..... | 6.15 |
| Charging the Propeller Air Dome | 6.16 |
| Tachometer Check..... | 6.17 |
| Cleaning Propellers | 6.17 |
| Propeller Repairs | 6.17 |
| Propeller Overhaul..... | 6.19 |
| The Hub | 6.19 |
| Prop Reassembly | 6.19 |
| Troubleshooting Propellers | 6.20 |
| Hunting and Surging | 6.20 |
| Engine Speed Varies With Flight Attitude (Airspeed) | 6.20 |
| Failure to Feather or Feathers Slowly | 6.20 |
| Propeller Governor Inspection, Maintenance, and Adjustment | 6.20 |
| Questions | 6.23 |
| Answers | 6.24 |

SUB-MODULE 07

PROPELLER STORAGE AND PRESERVATION

| | |
|---|-----|
| Knowledge Requirements | 7.1 |
| General | 7.2 |
| Long Term Storage and Preservation | 7.2 |
| Storage of Propeller Governors and Accumulators.. | 7.3 |
| During Preservation, Depreservation, and Return To Service | 7.4 |
| Questions | 7.7 |
| Answers | 7.8 |
| Acronyms | A.1 |
| Glossary | G.1 |
| Index | I.1 |

CONTENTS

PROPELLER

| | |
|-----------------------|------|
| Welcome | iii |
| Forward..... | iv |
| Preface..... | v |
| Revision Log..... | viii |
| Acknowledgments | viii |
| Contents | ix |

SUB-MODULE 01

FUNDAMENTALS

| | |
|------------------------------------|------|
| Knowledge Requirements | 1.1 |
| Introduction | 1.2 |
| Overview..... | 1.2 |
| Fundamentals | 1.3 |
| Basic Propeller Principles | 1.3 |
| Propeller Aerodynamic Process..... | 1.4 |
| Range of Propeller Pitch | 1.8 |
| Forces Acting on a Propeller | 1.9 |
| P-Factor | 1.10 |
| Slipstream Effect | 1.11 |
| Torque | 1.11 |
| Gyroscopic Precession | 1.11 |
| Vibration and Resonance..... | 1.12 |
| Questions | 1.13 |
| Answers | 1.14 |

SUB-MODULE 02

PROPELLER CONSTRUCTION

| | |
|--|-----|
| Knowledge Requirements | 2.1 |
| Propeller Construction..... | 2.2 |
| Propellers Used on General Aviation Aircraft | 2.2 |
| Fixed-Pitch Wooden Propellers | 2.2 |
| Torquing Wooden Propellers | 2.4 |
| Metal Fixed-Pitch Propellers | 2.5 |
| Steel Propeller Blades | 2.5 |
| Composite Propellers..... | 2.6 |
| Blade Stations | 2.6 |
| Propeller Hub, Shank, Back, and Face..... | 2.6 |
| Types of Propellers..... | 2.7 |
| Test Club Propeller..... | 2.7 |
| Fixed-Pitch Propeller | 2.7 |
| Ground-Adjustable Propeller | 2.8 |
| Controllable-Pitch Propeller | 2.8 |
| Constant-Speed Propellers | 2.8 |
| Feathering Propellers | 2.9 |

| | |
|---|------|
| Reverse-Pitch Propellers..... | 2.10 |
| Propeller Location | 2.10 |
| Tractor Propeller | 2.10 |
| Pusher Propellers | 2.10 |
| Contra-Rotating Propellers | 2.10 |
| Counter-Rotating Propellers | 2.11 |
| Propeller Removal and Installation..... | 2.11 |
| Removal..... | 2.11 |
| Installation | 2.12 |
| Questions | 2.15 |
| Answers | 2.16 |

SUB-MODULE 03

PROPELLER PITCH CONTROL

| | |
|--|------|
| Knowledge Requirements | 3.1 |
| Propeller Pitch Controls..... | 3.2 |
| Propeller Governor | 3.4 |
| Governor Mechanism..... | 3.4 |
| On Speed Condition..... | 3.6 |
| Under Speed Condition | 3.7 |
| Over Speed Condition | 3.7 |
| Constant-Speed Propeller Operations | 3.7 |
| Hartzell Constant-Speed, Non-feathering Propellers..... | 3.7 |
| Constant-Speed Feathering Propellers..... | 3.8 |
| Unfeathering | 3.10 |
| Autofeathering System | 3.11 |
| Hamilton Standard Hydromatic Propellers | 3.11 |
| Components | 3.12 |
| Hamilton Standard Propeller Control | 3.13 |
| Principles of Operation..... | 3.13 |
| Hydromatic On Speed Condition | 3.14 |
| Hydromatic Under Speed Condition | 3.14 |
| Over Speed Condition | 3.15 |
| Feathering Operation | 3.15 |
| Unfeathering Operation | 3.17 |
| Turboprop Engines and Propeller Control Systems | 3.18 |
| Reduction Gear Assembly | 3.19 |
| Turbo-Propeller Assembly | 3.19 |
| Pratt and Whitney PT-6 Hartzell Propeller System | 3.21 |
| Over Speed Protection | 3.24 |
| Electrically Controlled Propellers | 3.25 |
| Questions | 3.29 |
| Answers | 3.30 |

REVISION LOG

| VERSION | ISSUE DATE | DESCRIPTION OF CHANGE | MODIFICATION DATE |
|---------|------------|-----------------------------|-------------------|
| 001 | 2016 01 | Module Creation and Release | |
| | | | |
| | | | |
| | | | |
| | | | |
| | | | |
| | | | |
| | | | |
| | | | |
| | | | |

ACKNOWLEDGMENTS



| CERTIFICATION CATEGORY → | LEVELS | |
|--------------------------|--------|----|
| | A | B1 |

Sub-Module 06 - Propeller Maintenance

- Static and dynamic balancing;
- Blade tracking;
- Assessment of blade damage, erosion, corrosion, impact damage, delamination;
- Propeller treatment/repair schemes;
- Propeller engine running.

1

3

Sub-Module 07 - Propeller Storage and Preservation

- Propeller preservation and depreservation.

1

2

PREFACE

Propellers are the primary source of thrust for the most basic to many of the world's most advanced aircraft. Modern materials and the systems required for high performance flight have transformed propeller technology from the carved wooden blade still commonly used on many light and sport aircraft to complex systems designed to adjust pitch angle, self synchronize, and shed ice in foul weather conditions; all under the strain of tremendous horsepower of modern turbine engines. This module covers propellers and propeller systems, beginning with general theory of the fixed pitch prop to the inspection, repair, and preservation of full feathering and reversing blades, hydraulic and electric governors, plus electronic FADEC and de-ice systems. Some maintenance procedures described include balancing, tracking, vibration control, and preservation techniques. This module presents the B1 or A&P technician with what he or she needs to know for both a general understanding of these systems and the ability to work around them in an efficient and safe manner.

Module 17A Syllabus as outlined in PART-66, Appendix 1.

| CERTIFICATION CATEGORY → | LEVELS | |
|--|--------|----|
| | A | B1 |
| Sub-Module 01 - Fundamentals Blade element theory; High/low blade angle, reverse angle, angle of attack, rotational speed; Propeller slip; Aerodynamic, centrifugal, and thrust forces; Torque; Relative airflow on blade angle of attack; Vibration and resonance. | 1 | 2 |
| Sub-Module 02 - Propeller Construction Construction methods and materials used in wooden, composite and metal propellers; Blade station, blade face, blade shank, blade back and hub assembly; Fixed pitch, controllable pitch, constant speed propeller; Propeller/spinner installation. | 1 | 2 |
| Sub-Module 03 - Propeller Pitch Control Speed control and pitch change methods, mechanical and electrical/electronic; Feathering and reverse pitch; Overspeed protection. | 1 | 2 |
| Sub-Module 04 - Propeller Synchronizing Synchronizing and synchrophazing equipment. | - | 2 |
| Sub-Module 05 - Propeller Ice Protection Fluid and electrical de-icing equipment. | 1 | 2 |

FORWARD

PART-66 and the Acceptable Means of Compliance (AMC) and Guidance Material (GM) of the European Aviation Safety Agency (EASA) Regulation (EC) No. 1321/2014, Appendix 1 to the Implementing Rules establishes the Basic Knowledge Requirements for those seeking an aircraft maintenance license. The information in this Module of the Aviation Maintenance Technical Certification Series published by the Aircraft Technical Book Company meets or exceeds the breadth and depth of knowledge subject matter referenced in Appendix 1 of the Implementing Rules. However, the order of the material presented is at the discretion of the editor in an effort to convey the required knowledge in the most sequential and comprehensible manner. Knowledge levels required for Category A, B1, B2, and B3 aircraft maintenance licenses remain unchanged from those listed in Appendix 1 Basic Knowledge Requirements. Tables from Appendix 1 Basic Knowledge Requirements are reproduced at the beginning of each module in the series and again at the beginning of each Sub-Module.

How numbers are written in this book:

This book uses the International Civil Aviation Organization (ICAO) standard of writing numbers. This methods displays large numbers by adding a space between each group of 3 digits. This is opposed to the American method which uses commas and the European method which uses periods. For example, the number one million is expressed as so:

| | |
|-------------------|-----------|
| ICAO Standard | 1 000 000 |
| European Standard | 1.000.000 |
| American Standard | 1 000,000 |

SI Units:

The International System of Units (SI) developed and maintained by the General Conference of Weights and Measures (CGPM) shall be used as the standard system of units of measurement for all aspects of international civil aviation air and ground operations.

Prefixes:

The prefixes and symbols listed in the table below shall be used to form names and symbols of the decimal multiples and submultiples of International System of Units (SI) units.

| MULTIPLICATION FACTOR | PREFIX | SYMBOL |
|---|--------|--------|
| 1 000 000 000 000 000 000 = 10 ¹⁸ | exa | E |
| 1 000 000 000 000 000 = 10 ¹⁵ | peta | P |
| 1 000 000 000 000 = 10 ¹² | tera | T |
| 1 000 000 000 = 10 ⁹ | giga | G |
| 1 000 000 = 10 ⁶ | mega | M |
| 1 000 = 10 ³ | kilo | k |
| 100 = 10 ² | hecto | h |
| 10 = 10 ¹ | deca | da |
| 0.1 = 10 ⁻¹ | deci | d |
| 0.01 = 10 ⁻² | centi | c |
| 0.001 = 10 ⁻³ | milli | m |
| 0.000 001 = 10 ⁻⁶ | micro | μ |
| 0.000 000 001 = 10 ⁻⁹ | nano | n |
| 0.000 000 000 001 = 10 ⁻¹² | pico | p |
| 0.000 000 000 000 001 = 10 ⁻¹⁵ | femto | f |
| 0.000 000 000 000 000 001 = 10 ⁻¹⁸ | atto | a |

International System of Units (SI) Prefixes

WELCOME

The publishers of this Aviation Maintenance Technician Certification Series welcome you to the world of aviation maintenance. As you move towards EASA certification, you are required to gain suitable knowledge and experience in your chosen area. Qualification on basic subjects for each aircraft maintenance license category or subcategory is accomplished in accordance with the following matrix. Where applicable, subjects are indicated by an "X" in the column below the license heading.

For other educational tools created to prepare candidates for licensure, contact Aircraft Technical Book Company.

We wish you good luck and success in your studies and in your aviation career!

EASA LICENSE CATEGORY CHART

| Module number and title | | A1 Airplane Turbine | B1.1 Airplane Turbine | B1.2 Airplane Piston | B1.3 Helicopter Turbine | B2 Avionics |
|-------------------------|--|---------------------------|-----------------------------|----------------------------|-------------------------------|----------------|
| 1 | Mathematics | X | X | X | X | X |
| 2 | Physics | X | X | X | X | X |
| 3 | Electrical Fundamentals | X | X | X | X | X |
| 4 | Electronic Fundamentals | | X | X | X | X |
| 5 | Digital Techniques / Electronic Instrument Systems | X | X | X | X | X |
| 6 | Materials and Hardware | X | X | X | X | X |
| 7A | Maintenance Practices | X | X | X | X | X |
| 8 | Basic Aerodynamics | X | X | X | X | X |
| 9A | Human Factors | X | X | X | X | X |
| 10 | Aviation Legislation | X | X | X | X | X |
| 11A | Turbine Aeroplane Aerodynamics, Structures and Systems | X | X | | | |
| 11B | Piston Aeroplane Aerodynamics, Structures and Systems | | | X | | |
| 12 | Helicopter Aerodynamics, Structures and Systems | | | | X | |
| 13 | Aircraft Aerodynamics, Structures and Systems | | | | | X |
| 14 | Propulsion | | | | | X |
| 15 | Gas Turbine Engine | X | X | | X | |
| 16 | Piston Engine | | | X | | |
| 17A | Propeller | X | X | X | | |



PROPELLER

FUNDAMENTALS

SUB-MODULE 01

PART-66 SYLLABUS LEVELS
 CERTIFICATION CATEGORY →

| A | B1 |
|---|----|
| 1 | 2 |

Sub-Module 01
FUNDAMENTALS
 Knowledge Requirements

17.1 - Fundamentals

- Blade element theory;
- High/low blade angle, reverse angle, angle of attack, rotational speed;
- Propeller slip;
- Aerodynamic, centrifugal, and thrust forces;
- Torque;
- Relative airflow on blade angle of attack;
- Vibration and resonance.

Level 1

A familiarization with the principal elements of the subject.

Objectives:

- (a) The applicant should be familiar with the basic elements of the subject.
- (b) The applicant should be able to give a simple description of the whole subject, using common words and examples.
- (c) The applicant should be able to use typical terms.

Level 2

A general knowledge of the theoretical and practical aspects of the subject and an ability to apply that knowledge.

Objectives:

- (a) The applicant should be able to understand the theoretical fundamentals of the subject.
- (b) The applicant should be able to give a general description of the subject using, as appropriate, typical examples.
- (c) The applicant should be able to use mathematical formula in conjunction with physical laws describing the subject.
- (d) The applicant should be able to read and understand sketches, drawings and schematics describing the subject.
- (e) The applicant should be able to apply his knowledge in a practical manner using detailed procedures.

INTRODUCTION

During the invention era of the airplane, the propeller proved to be a very difficult challenge. Early aviation pioneers made crude propellers that were inefficient. This further complicated the invention process by requiring a larger propeller to provide the requisite thrust to propel the airplane at or above its minimum flying speed. Furthermore, the larger propeller required a more powerful engine and sturdier structure, which further compounded the problem by increasing weight, which meant more lift was needed to ascend from the surface.

The Wright Brothers are credited with developing and implementing effective theories regarding the design of propellers. Their early, hand-carved wooden propellers were remarkably efficient for their day. They considered the propeller to be a rotating airfoil. Upon reflecting on the designing aspect of their propellers, Orville Wright concluded, "... on further consideration it is hard to find even a point from which to make a start; for nothing about a propeller, or the medium in which it acts, stands still for a moment. The thrust depends upon the speed and the angle at which the blade strikes the air; the angle at which the blade strikes the air depends upon the speed at which the propeller is turning, the speed the machine is travelling forward, and the speed at which the air is slipping backward; the slip of the air backwards depends upon the thrust exerted by the propeller, and the amount of air acted upon. When any one of these changes, it changes all the rest, as they are interdependent upon one another. But these are only a few of the many factors that must be considered and determined in calculating and designing propellers."

OVERVIEW

The propeller, the component that must absorb the power output of the engine, has passed through many stages of development. Although most propellers are two-bladed, great increases in power output have resulted in the development of four-, five-, and six-bladed propellers of large diameters. However, all propeller-driven aircraft are limited by the revolutions per minute (rpm) at which propellers can be turned.

There are several forces acting on the propeller as it turns; a major one is centrifugal force. This force at high rpm tends to pull the blades out of the hub. Thus, blade weight and hub strength are very important to the design of a propeller. Excessive blade tip speed (rotating the propeller too fast) may result not only in poor blade efficiency, but also in flutter and vibration. Since the propeller speed is limited, the forward speed of a propeller driven airplane is also limited—to approximately 400 miles per hour (mph) or 650 km/h or 350 knots. As aircraft speeds increased, turbine engines were used for higher speed aircraft. Propeller-driven aircraft have several advantages over pure jets and are thus widely used for several applications. Among those advantages are a generally lower cost and shortened takeoff and landing distances for operation at smaller airports. New blade materials and manufacturing techniques have increased the efficiency of propellers. Many smaller aircraft will continue to use propellers well into the future.

Many different types of propeller systems have been developed for specific aircraft installation, speed, and mission. Propeller development has encouraged many

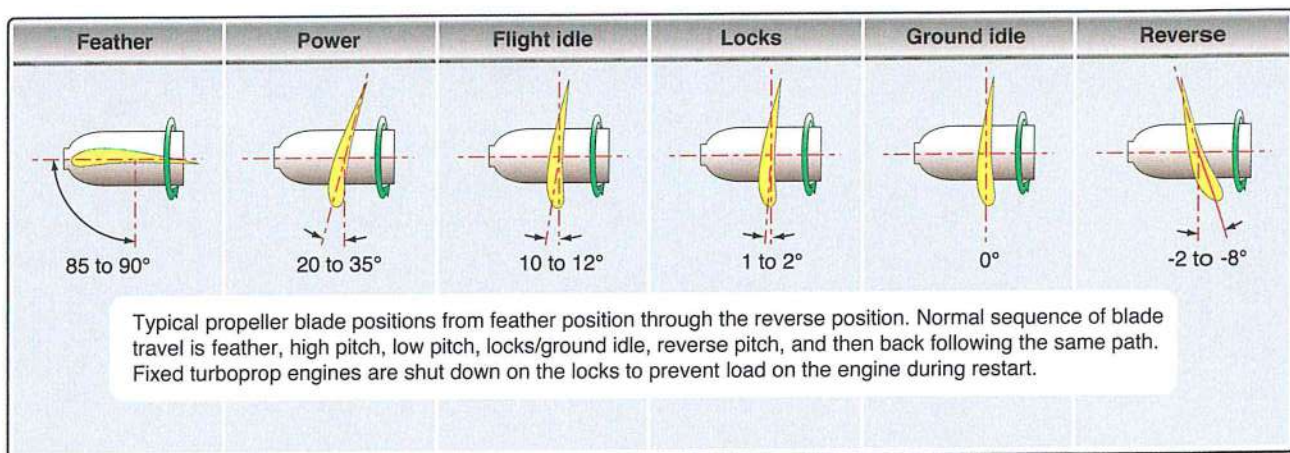

Figure 1-1. Ranges of Propeller Pitch.

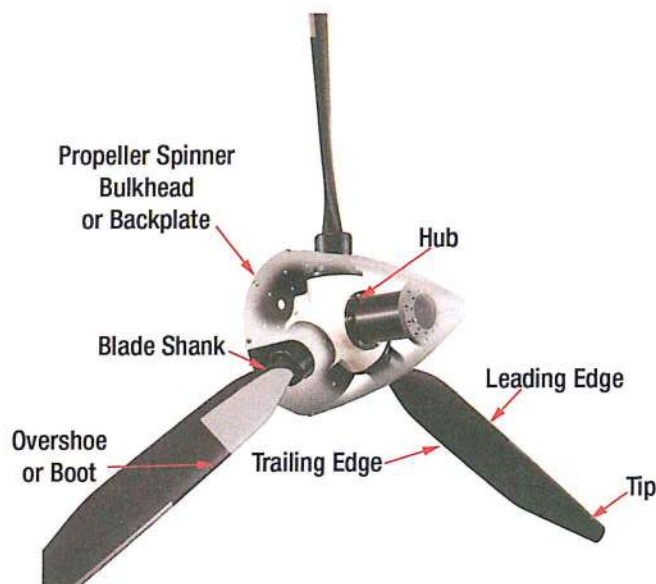

Figure 1-2. Parts of a Propeller.

changes as propulsion systems have evolved. Early experimental propellers, which proved unsuccessful, were sticks extended from the hub in which fabric was stretched across. They forced air in a rearward direction. Successful propellers started as simple two-bladed wood propellers and have advanced to the complex propulsion systems of turboprop aircraft that involve more than just the propeller blades. As an outgrowth of operating large, more complex propellers, a variable-pitch, constant-speed feathering and reversing propeller system was developed. This system allows the engine rpm to be varied only slightly during different flight conditions and, therefore, increases flying efficiency. A basic constant-speed system consists of a flyweight-equipped governor unit that controls the pitch angle of the blades so that the engine speed remains constant. The governor can be regulated by controls in the cockpit so that any desired blade angle setting and engine operating speed can be obtained. A low pitch, high rpm setting, for example, can be utilized for takeoff. Then, after the aircraft is airborne, a higher

pitch and lower rpm setting can be used for cruise operations. *Figure 1-1* shows normal propeller movement with the positions of low pitch, high pitch, feather (used to reduce drag if the engine quits), and zero pitch into negative pitch, or reverse pitch.

FUNDAMENTALS

The basic nomenclature of the parts of a propeller is shown in *Figure 1-2*. The aerodynamic cross-section of a propeller blade presented in *Figure 1-3* includes terminology to describe relevant elements of a blade.

BASIC PROPELLER PRINCIPLES

The aircraft propeller consists of two or more blades and a central hub to which the blades are attached. Each blade of an aircraft propeller is essentially a rotating wing. As a result of their construction, the propeller blades produce forces that create thrust to pull or push the airplane through the air. The power needed to rotate the propeller blades is furnished by the engine. The propeller is mounted on a shaft that may be an extension of the crankshaft on low-horsepower engines.

On high horsepower engines, it is mounted on a propeller shaft that is geared to the engine crankshaft. In either case, the engine rotates the airfoils of the blades through the air at high speeds, and the propeller transforms the rotary power of the engine into thrust.

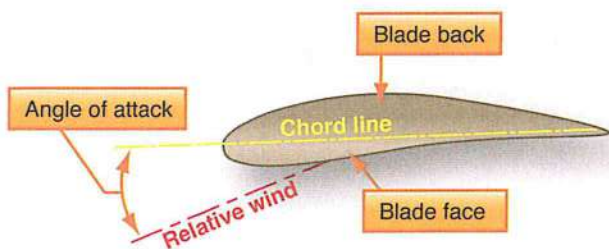

Figure 1-3. Cross Section of Propeller Airfoil.

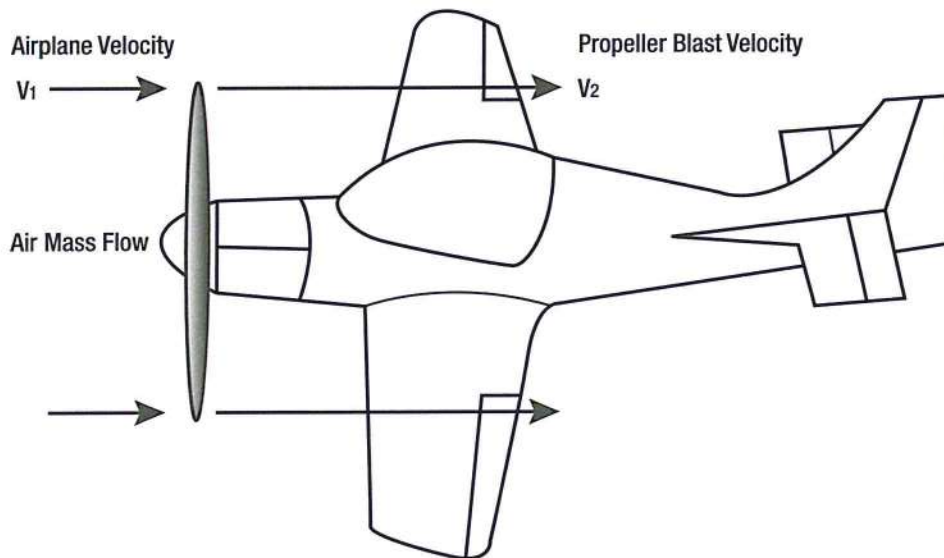

Figure 1-4. Thrust.

The thrust produced by the engine/propeller combination is the result of how much air is pushed and the speed of the moving air mass. The resulting action/reaction is in accordance with Newton's Third Law of Motion. In comparison to a jet engine, a propeller moves a large mass of air at a relatively slow speed.

$$\text{Thrust} = \text{Mass} (V_2 - V_1)$$

PROPELLER AERODYNAMIC PROCESS

An airplane moving through the air creates a drag force opposing its forward motion. If an airplane is to fly on a level path at a constant speed, there must be a force applied to it that is equal to the drag but acting forward. This force is called thrust. The work done by thrust is equal to the thrust times the distance it moves the airplane.

$$\text{Work} = \text{Thrust} \times \text{Distance}$$

The power expended by thrust is equal to the thrust times the velocity at which it moves the airplane.

$$\text{Power} = \text{Thrust} \times \text{Velocity}$$

If the power is measured in horsepower units, the power expended by the thrust is termed thrust horsepower. The engine supplies brake horsepower through a rotating shaft, and the propeller converts it into thrust horsepower. In this conversion, some power is wasted. For maximum

efficiency, the propeller must be designed to keep this waste as small as possible. Since the efficiency of any machine is the ratio of the useful power output to the power input, propeller efficiency is the ratio of thrust horsepower to brake horsepower. The usual symbol for propeller efficiency is the Greek letter η (eta). Propeller efficiency varies from 50 percent to 87 percent, depending on how much the propeller slips.

Pitch is not the same as blade angle, but because pitch is largely determined by blade angle, the two terms are often used interchangeably. An increase or decrease in one is usually associated with an increase or decrease in the other. Propeller slip is the difference between the geometric pitch of the propeller and its effective pitch. (Figure 1-5) Geometric pitch is the distance a propeller should advance in one revolution with no slippage.

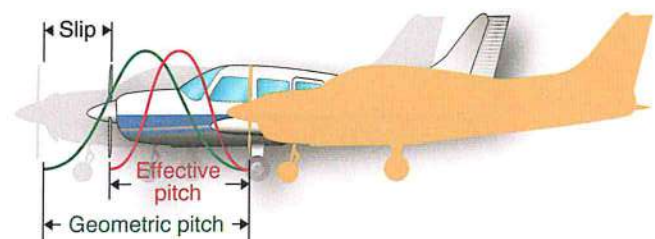

Figure 1-5. Effective Pitch versus Geometric Pitch.

Effective pitch is the distance it actually advances. Thus, geometric or theoretical pitch is based on no slippage.

Actual, or effective, pitch recognizes propeller slippage in the air. The relationship can be shown as:

$$\text{Slip} = \text{Geometric pitch} - \text{Effective pitch}$$

Geometric pitch is usually expressed in pitch inches and calculated by using the following formula:

$$GP = 2 \times \pi R \times \text{tangent of blade angle at 75 percent station}$$

$$R = \text{Radius at the 75 percent blade station and } \pi = 3.14$$

Blade angle and propeller pitch are closely related. Blade angle is the angle between the face or chord of a blade section and the plane in which the propeller rotates. (Figure 1-6) The chordline of the propeller blade is determined in about the same manner as the chordline of an airfoil. In fact, a propeller blade can be considered as being composed of an infinite number of thin blade elements, each of which is a miniature airfoil section whose chord is the width of the propeller blade at that section. Because most propellers have a flat blade face, the chord line is often drawn along the face of the propeller blade.

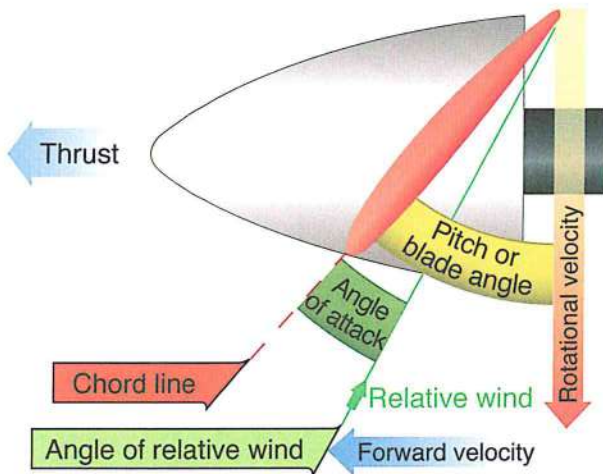

Figure 1-6. Propeller Aerodynamics.

The typical propeller blade can be described as a twisted airfoil of irregular planform. Two views of a propeller blade are shown in Figure 1-7. For purposes of analysis, a blade can be divided into segments that are located by station numbers in inches from the center of the blade hub. The cross-sections of each 6-inch blade segment

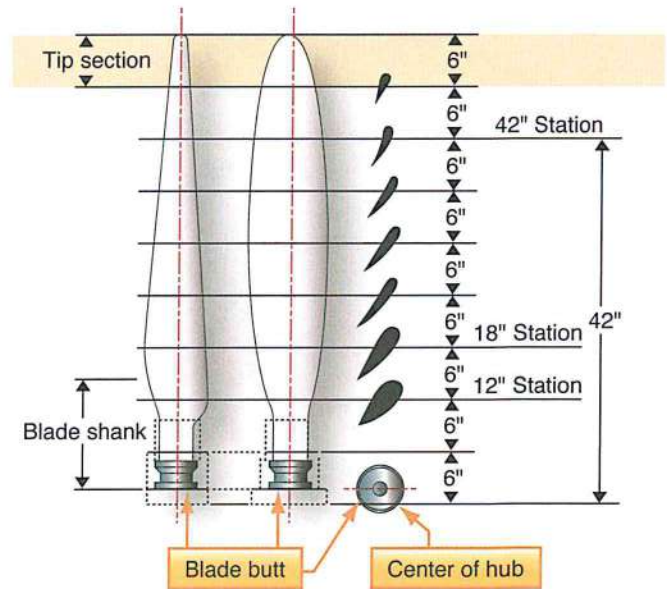

Figure 1-7. Propeller blade elements demonstrating twist.

are shown as airfoils in the right side of Figure 1-7. Also identified in Figure 1-7 are the blade shank and the blade butt. The blade shank is the thick, rounded portion of the propeller blade near the hub and is designed to give strength to the blade. The blade butt, also called the blade base or root, is the end of the blade that fits in the propeller hub. The blade tip is that part of the propeller blade farthest from the hub, generally defined as the last 6 inches of the blade. In the blade element theory, the propeller blade is divided into small segments so that the performance of each segment may be critically analyzed. By combining the performance of the segments, designers are able to closely predict the performance of the propeller.

The cross-section of a typical propeller blade is shown in Figure 1-3. This blade element is an airfoil comparable to a cross-section of an aircraft wing. The blade back is the cambered or curved side of the blade, similar to the upper surface of an aircraft wing. The blade face is the relatively flat side of the propeller blade similar to the undersurface of a wing. The chord line is an imaginary line drawn through the blade from the leading edge to the trailing edge. The leading edge is the thick edge of the blade that meets the air as the propeller rotates.

As seen in Figure 1-7, the propeller blade is designed with a twisting component. The angle of the blade near the hub is higher than the angle at the tip. The reason the propeller blade needs the twist is due to the difference in velocity between the blade at the hub versus

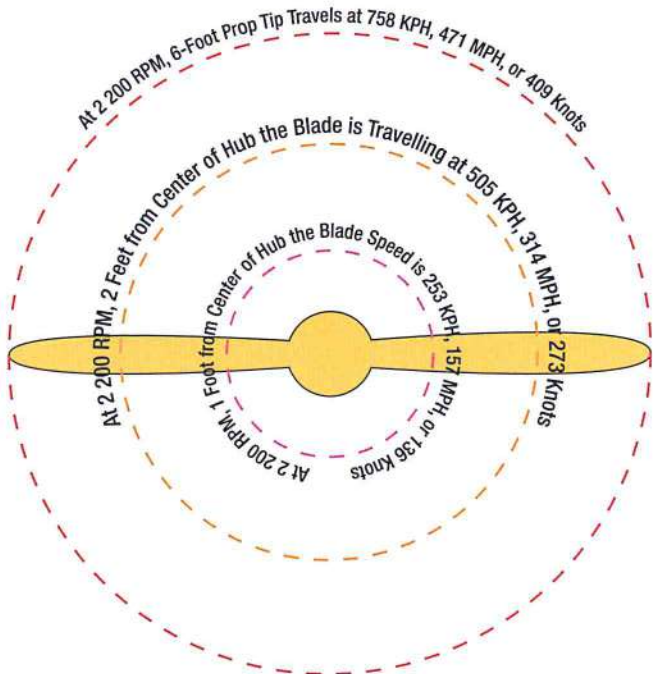

Figure 1-8. Velocities along blade span.

the blade at the tip. (Figure 1-8) The lower speeds at the hub region benefit from the higher blade angle while the higher speeds at the tip require a lesser blade angle. The

pitch of the blade changes progressively from the root to the tip to provide the proper interaction with the air along the entire length of the blade.

There is a distinction between blade angle and angle of attack. The blade angle for each segment of a fixed-pitch propeller is the angle formed by the chord line of the blade segment and its plane of rotation. That relationship does not change. (Figure 1-9) The same is true for controllable-pitch propellers once the blade angle is established. By contrast, the angle of attack of a fixed-pitch propeller blade varies with forward speed of the aircraft. (Figure 1-10) The faster the airspeed of the airplane, the less the angle of attack.

As seen in Figure 1-10, the relative airflow (RAF) encountered by the propeller varies with the speed of the airplane. When the aircraft is traveling at a low airspeed, the angle of attack encountered by the propeller blade is high. The thrust for a given rpm will be high due to the high angle of attack. In terms of efficiency, the slow moving airplane will have poor propeller efficiency. At high airspeeds, the angle of attack of the propeller is relatively low.

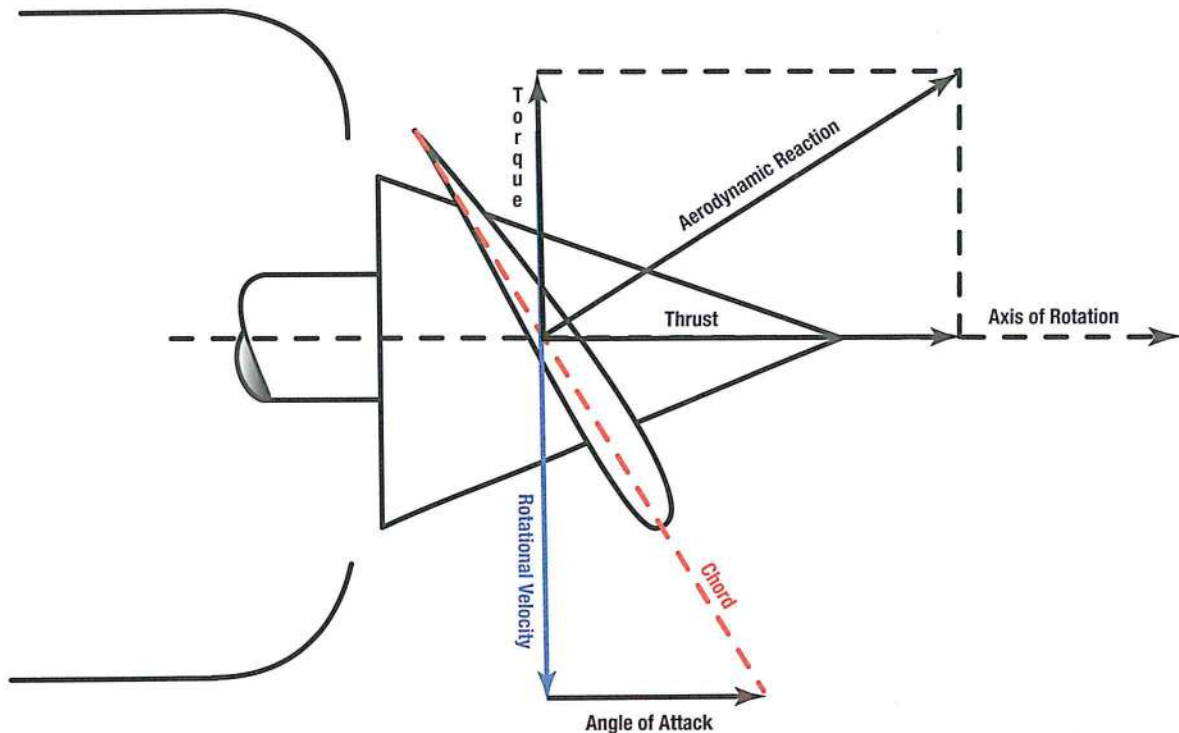

Figure 1-9. Propeller blade angle with no forward airspeed.

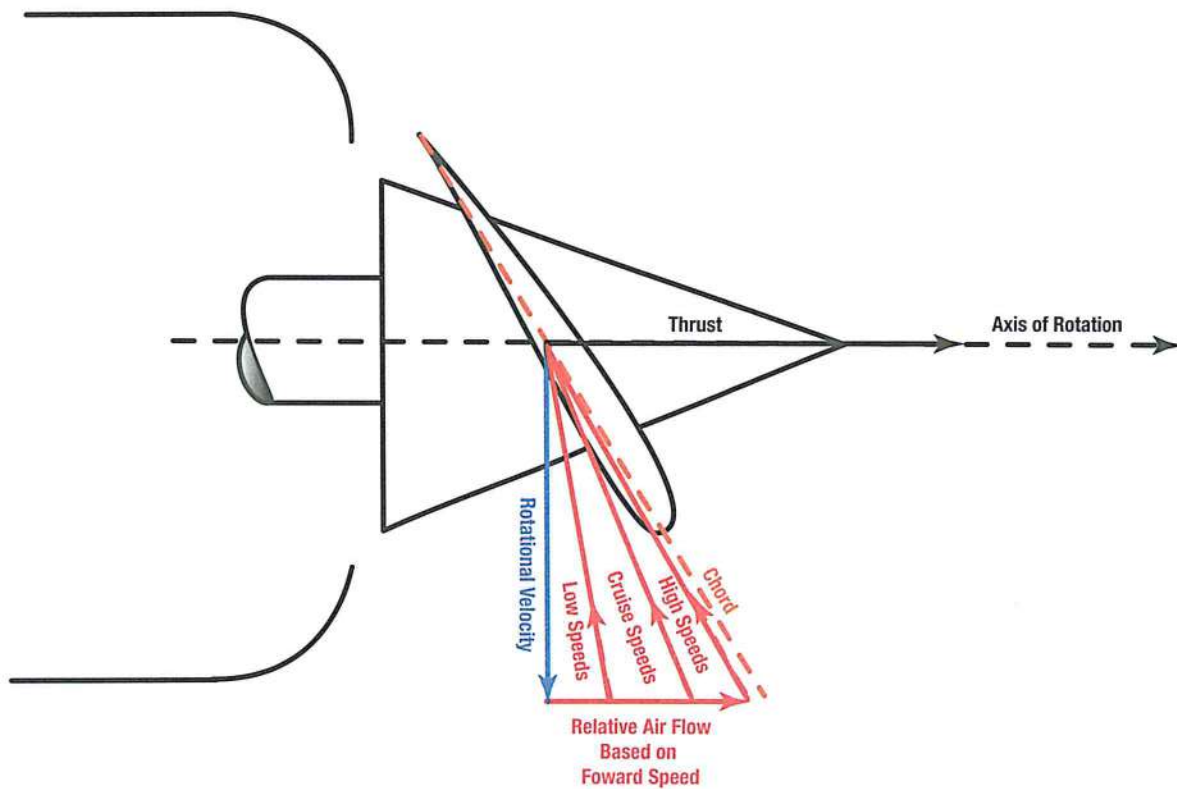

Figure 1-10. Relative air flow based on forward speed.

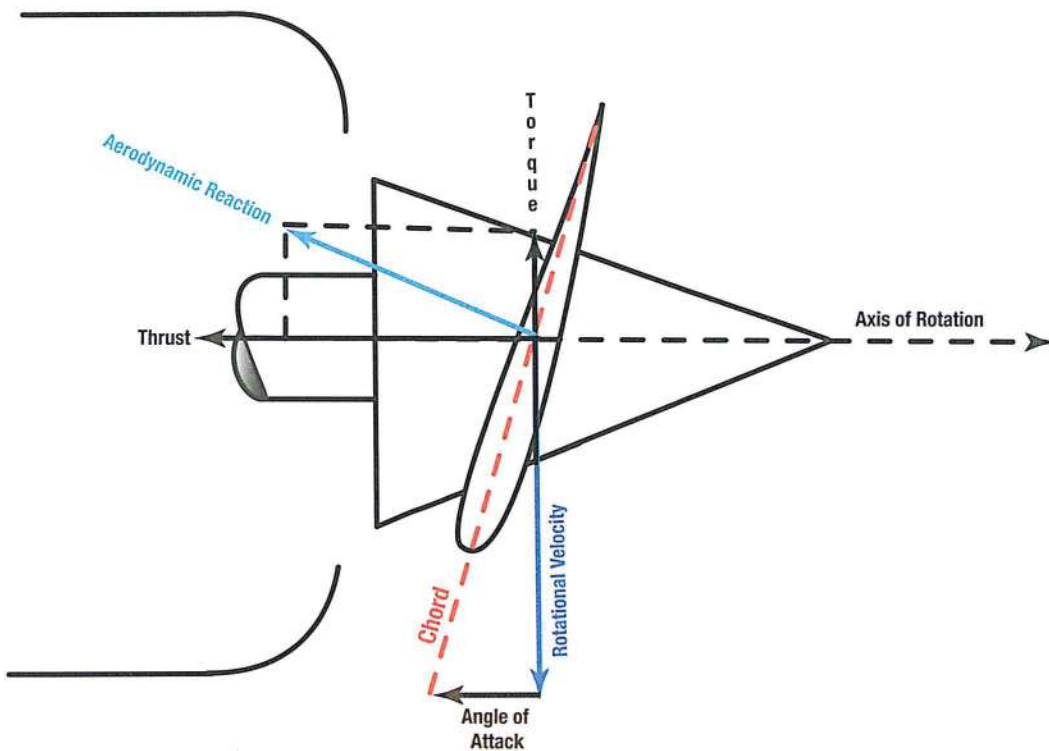

Figure 1-11. Reverse Thrust.

Where a large number of small airplanes use fixed-pitch propellers, a majority of higher performance aircraft are equipped with propellers that are variable pitch. This allows the operator to vary the pitch of the propeller during flight to increase the efficiency of the propeller in order to yield the desired performance in terms of speed and fuel economy. These propellers often include a constant-speed mechanism that keeps the engine at the same rpm during cruise flight. When the aircraft changes flight attitude (e.g., nose up for altitude gain), the propeller changes pitch to keep the engine at the same rpm.

Some propellers are able to produce reverse thrust. This is accomplished by reducing the pitch angle to achieve a negative angle of attack. This produces reverse thrust that serves as a means of aerodynamic braking to reduce aircraft speed following landing. The ability to reverse the thrust of the propeller is useful for slowing the aircraft after touching down, thereby shortening the length of roll out and allowing the aircraft to operate from a shorter runway than it could otherwise use without reverse thrust while saving a measure of wear on the brake system. Some aircraft are able to back-up on the ground using reverse thrust. Reverse thrust may prove useful when maneuvering a seaplane, especially during docking. (Figure 1-11)

Multiengine aircraft are normally equipped with propellers that may be feathered. This feature is useful for when the aircraft experiences a dead engine or an engine incapable of producing proper thrust during flight. Without the ability to feather the propeller, the dead or weak engine would windmill or attempt to windmill. Such action generates detrimental drag, making it more difficult for the aircraft to sustain altitude.

When the propeller is feathered the blade angle is close to 90°. Where the propeller tip may not appear to be perpendicular to the plane of rotation, the higher angle of attack of the blade towards the hub is also in play. The net result of the aerodynamic action acting on the entire blade is that the propeller does not rotate the engine. The drag produced by the propeller is relatively low as the blades slice through the air during flight. (Figure 1-12)

RANGE OF PROPELLER PITCH

Depending on the design of the propeller, the range of pitch may extend from reverse thrust to feathered. Generally speaking, higher performance turboprop aircraft have propellers that include the full range of travel. This provides the aircraft with sufficient propeller capabilities to meet operational requirements. (Figure 1-13)

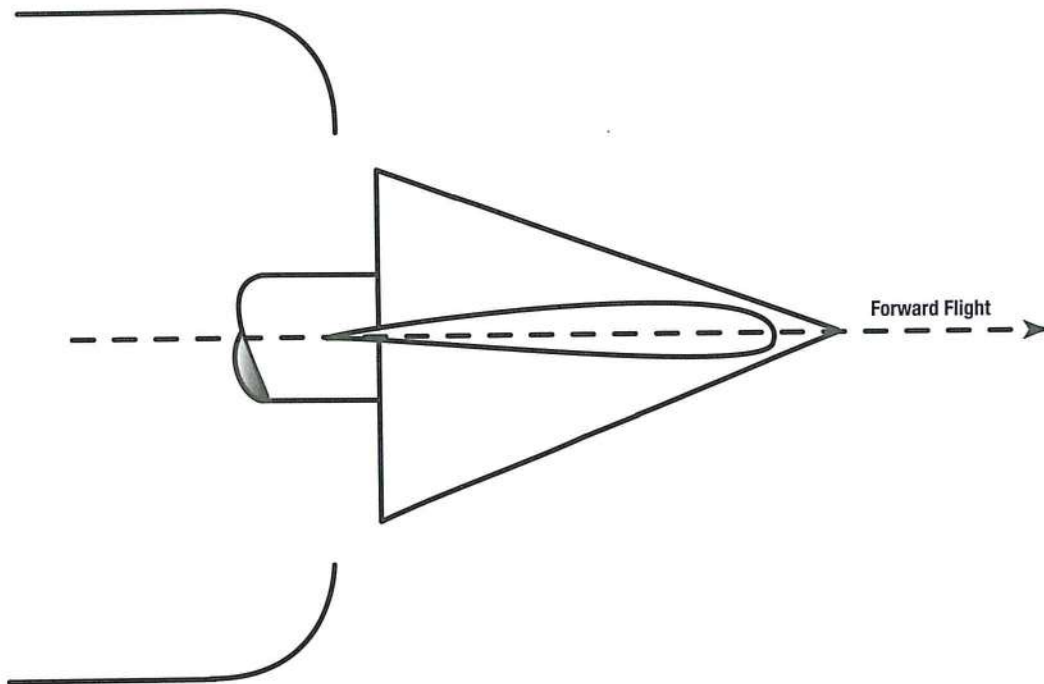

Figure 1-12. Feathered propeller blade.

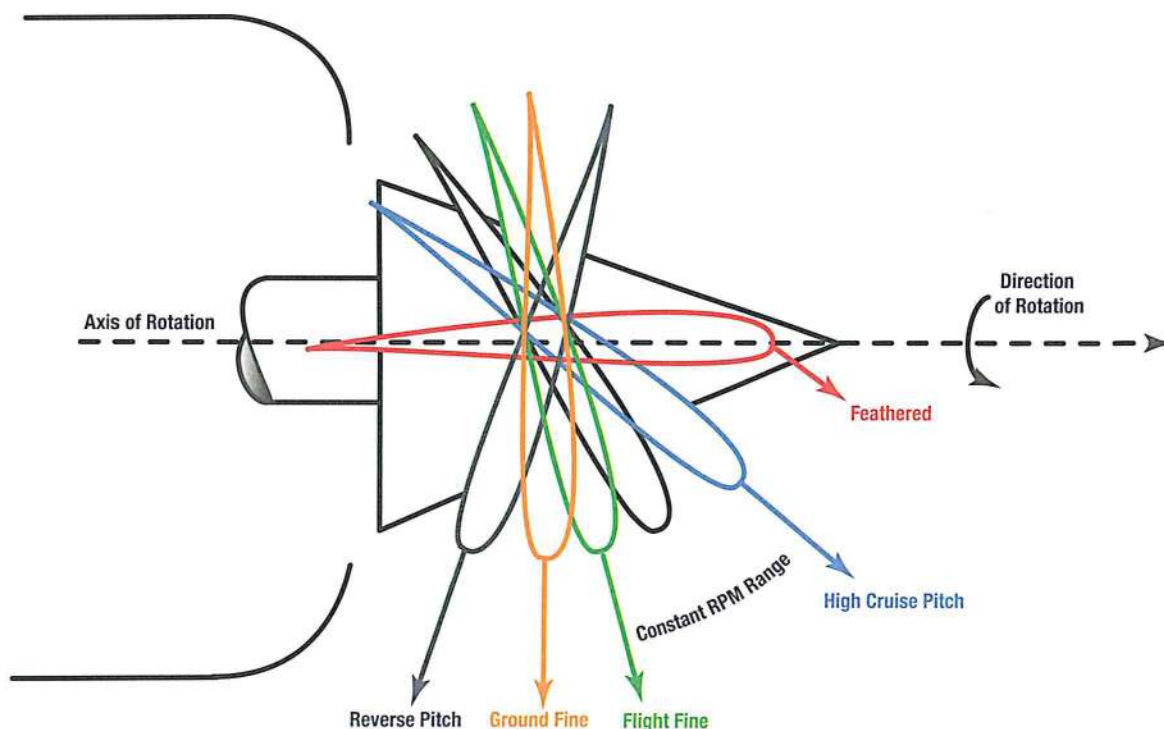

Figure 1-13. Range of propeller pitch for a variety of flight parameters.

FORCES ACTING ON A PROPELLER

The propeller is subjected to numerous forces. The level of force may be extreme, depending on the operation. Forces acting on the propeller during flight include: (a) centrifugal force, (b) torque bending force, (c) thrust bending force, (d) aerodynamic twisting force, and (e) centrifugal twisting force as shown in *Figure 1-14*. A description of each is provided.

Centrifugal force is a physical action that tends to pull the rotating propeller blades out of the hub. (*Figure 1-14A*) This is the most dominant force on the propeller. The centrifugal load exerted by the blades at high rpm is measured in tons. Damage to the propeller near the root or damage to the hub may result in blade separation.

Torque bending force, in the form of air resistance, tends to bend the propeller blades in the direction opposite than of rotation. (*Figure 1-14B*) The resistance generated by the rotating blades is basically drag. Under varying flight configurations, the pilot has to use the flight controls to compensate for the torque generated by the engine/propeller combination.

Thrust bending force is the thrust load that bends propeller blades forward as the aircraft is pulled through the air. (*Figure 1-14C*) The thrust bending force is more prominent at the tip of the propeller blade. The relative thinness of the propeller blade in the tip area allows that section to bend forward in response to the generation of thrust.

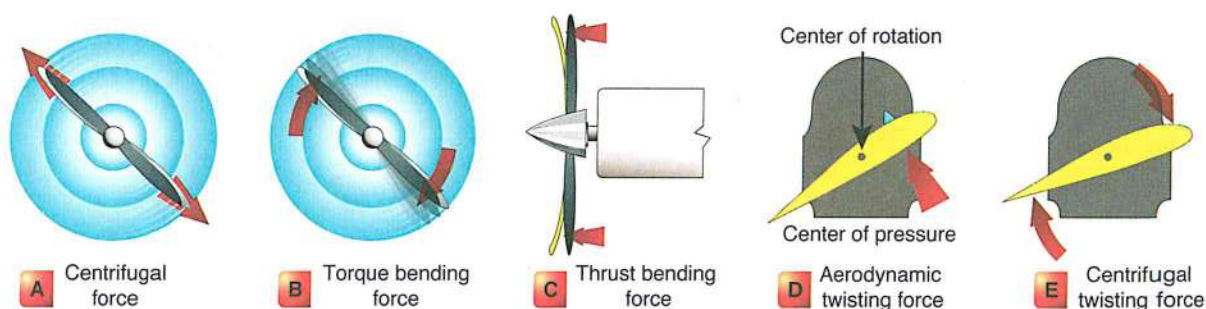

Figure 1-14. Forces acting on a propeller.

Aerodynamic twisting force (ATF), also known as aerodynamic twisting moment (ATM), tends to rotate the propeller blades to a high blade angle. (Figure 1-14D) This force is generated as the propeller produces thrust. Because the axis of rotation of the propeller blade in terms of pitch angle is approximately the midpoint along the chord, the center of pressure generated by the aerodynamic action of the blade interacting with the air imparts a force nearer the leading edge of the blade. The result is that the blade tries to move in the direction of higher pitch. ATM may be incorporated to increase the pitch of the blades during flight.

Centrifugal twisting force (CTF), also known as centrifugal twisting moment (CTM), is generated as the propeller rotates. Because the axis of blade pitch rotation is basically the midpoint of the chord, the mass of the propeller blade on each side of the axis of rotation works to reduce propeller pitch due to the centrifugal force generated. As with the other forces acting on the propeller blades, the higher the rpm, the greater the CTM. When compared to the aerodynamic twisting moment, the centrifugal twisting moment is more powerful and tends to force the propeller blades toward a low blade angle. (Figure 1-14E)

Two of these forces acting on the propeller's blades are used to move the blades on a controllable pitch propeller. Centrifugal twisting moment (CTM) is sometimes used to move the blades to the low pitch position, while aerodynamic twisting moment (ATM) is used to move the blades into high pitch. These forces can be the primary or secondary forces that move the blades to the new pitch position.

In terms of construction, a propeller must be capable of withstanding severe stresses, which are greater near the hub, caused by centrifugal force and thrust. The stresses increase in proportion to the rpm. The blade face is also subjected to tension from the centrifugal force and additional tension from the thrust bending force. For these reasons, nicks or scratches on the blade may cause very serious consequences. These could lead to cracks and failure of the blade and are addressed in the repair section later in this book.

A propeller must also be rigid enough to prevent fluttering, a type of vibration in which the ends of the blade twist back and forth at high frequency around an axis perpendicular to the engine crankshaft. Fluttering is accompanied by a distinctive noise, often mistaken for exhaust noise. The constant vibration and resonance tends to weaken the blade and eventually causes failure.

P-FACTOR

When an airplane is flying in a level attitude, the thrust developed by the propeller is fairly uniform between the descending blade and the ascending blade. Raising the nose of the aircraft produces asymmetrical thrust between the ascending and descending propeller blades. This is often referred to as "P-Factor."

P-Factor is generated during climbs because the descending blade has a greater angle of attack than the ascending blade. The difference in thrust between the right and left regions of the propeller disc generates a yawing moment. For right-hand rotating propellers, a left yawing moment is formed. Pilots compensate for P-Factor by applying the necessary rudder input. (Figure 1-15)

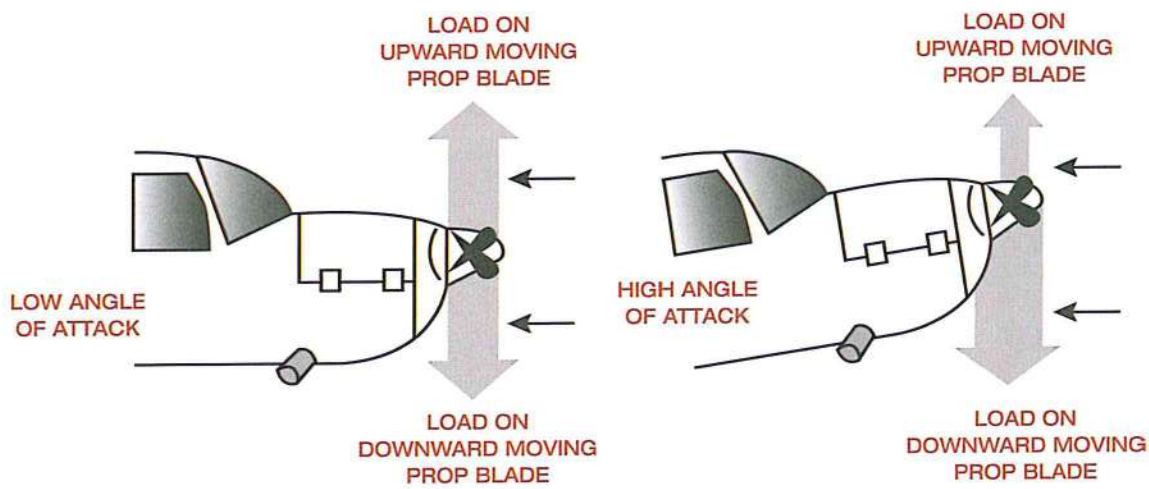

Figure 1-15. P-Factor.

SLIPSTREAM EFFECT

Another occurrence generated by the flowing air mass of the propeller is the slipstream effect. As the air acted upon by the propeller flows aft, it flows around the surface of the aircraft at an accelerated speed when compared to air flowing over the surface outside the propeller disc. Control surfaces within the path of the slipstream benefit from the accelerated flow and become more effective.

The slipstream generated by the propeller also has a whirling action as it flows aft. This rotating air mass on single-engine aircraft, or aircraft with a propeller in the nose, experience a yawing action due to the striking of the air against the vertical fin. For right-hand rotating propellers, the aircraft develops a yawing moment to the left. Aircraft designers often compensate for the slipstream effect by offsetting the vertical fin, incorporating a corrective measure with the rudder, or applying a slight offset of the thrust line of the engine by designing the engine mount with a corrective installation angle. Such corrective measures may also soften the effect of P-Factor. *(Figure 1-16)*

TORQUE

Torque is a natural resistance to a rotating mass. As the propeller revolves in one direction, torque works to rotate the airplane in the opposite direction. This follows Newton's Third Law of Motion that states, for every action there is an equal and opposite reaction.

On a right-hand rotating propeller, torque works to drop the left wing. The greater the power/rpm, the greater the torque effect. High power operations, in combination with low airspeeds, increase the torque effect. Often aerobatic pilots will demonstrate "torque rolls" by pointing the nose of the airplane vertically up with full power. As the airspeed approaches zero, the aircraft will begin to revolve in the opposite direction of the rotating propeller.

Pilots experience the effect of torque, P-Factor, and slipstream effect when they perform power-on stalls. During the maneuver, the throttle is placed at full power and the nose of the aircraft is lifted until the aircraft stalls. When the stall is entered, the pilot will implement corrective control inputs to compensate for the torque and other effects while recovering from the stall. If the throttle is reduced to idle, or a low-power setting during the stall, the effects of torque, P-Factor, and slipstream action are greatly reduced.

GYROSCOPIC PRECESSION

The rotating propeller is, in effect, a gyroscope. The rotating mass will generate a measure of gyroscopic rigidity and precession. The latter produces a small, but noticeable, reaction during operation.

Gyroscopic precession is the response of a gyroscope to generate an action 90° from the point of input in the direction of rotation. To illustrate, when an aircraft equipped with a right-hand rotating propeller is yawed to the left, gyroscopic precession will work to lift the nose.

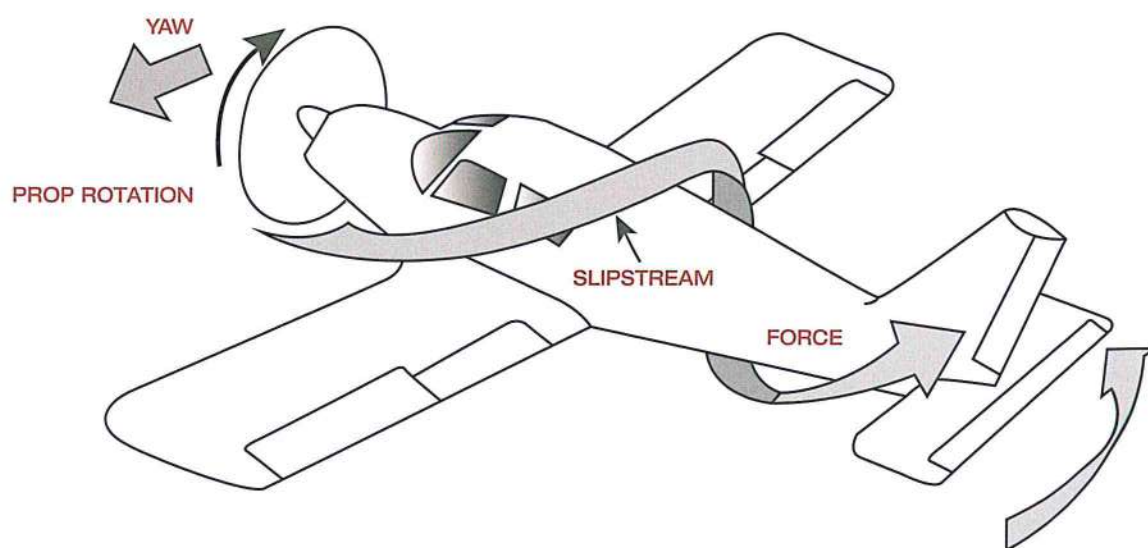

Figure 1-16. Slipstream Effect.

During takeoff roll of an aircraft equipped with a tail wheel, when the pilot raises the tail, the aircraft develops a yawing action to the left.

In general, the effects of gyroscopic precession are minor. The pilot is able to make inputs into the flight control system to counteract gyroscopic precession.

VIBRATION AND RESONANCE

During operation, the propeller is subjected to vibrations. The mechanical and aerodynamic forces acting on the propeller generate vibrations. Such vibrations are harmful when they result in extreme blade flexing. High levels of flexing will work harden the metallic blade and may cause sections of the blade to break off. The area near the propeller tip is of great concern as the thinness of the metal in combination with the high air speeds encountered during high rpm operations make this portion of the propeller blade vulnerable. Manufacturers of propellers must design the propeller to withstand the operational vibration for the particular airframe/engine/propeller installation. Some aircraft have red arcs on the tachometer to indicate operational rpms that are harmful.

Pilots are allowed to accelerate and decelerate through and beyond the red arc, or critical rpm range, but must avoid continuous operations within the range of the red arc. (Figure 1-17)

Metal propeller blades may possess multiple resonant frequencies, usually two, that result in considerable flexing of the blade. The hinge point where the flexing concentrates is referred to as a node point or nodal point. If the blade receives physical damage in this exact location or a repair is improperly performed at the node point, there is a likelihood that the blade will fail at that location over the course of operations.

Between the mechanical impulses applied to the propeller and the aerodynamic forces absorbed by the propeller, metal propeller blades, usually aluminum, must be designed to withstand the natural vibrations generated during operation. A proven approach to minimizing damage that may occur to the propeller from resonance is to generate forces between the airframe, engine, and propeller that do not closely match the natural resonant frequencies of the propeller.



Figure 1-17. Red arc from 1 800 to 2 000 rpm.

QUESTIONS

Question: 1-1

What two factors determine the amount of thrust produced by a propeller?

Question: 1-6

What remains “constant” on a constant speed propeller?

Question: 1-2

What are two reasons why an additional 3rd or 4th blade would be added to a propeller?

Question: 1- 7

Of the principle 5 forces acting on a propeller in flight, which is the greatest in terms of pressure?

Question: 1-3

Compared to its take-off setting, in a cruise flight a propeller system is most efficient when configured with a _____ pitch angle and the engine turning at a _____ rpm.

Question: 1-8

Of the principle 5 forces acting on a propeller in flight, which is compensated for by the pilot?

Question: 1-4

When would an aircraft propeller be “feathered”?

Question: 1-9

Which of the principle 5 forces acting on a propeller in flight acts as an advantage when adjusting a propeller from a climb configuration to a cruise configuration?

Question: 1-5

In order to provide even thrust through the entire length of a propeller blade, the blade is constructed so that the root is at a _____ pitch, and the tip is at a _____ pitch.

Question: 1-10

At what stage of flight does P-factor have the greatest affect on the directional control of an aircraft?

ANSWERS

Answer: 1-1

The angle of pitch and the speed of rotation.

Answer: 1-6

The rpm of the engine.

Answer: 1-2

Allows a smaller diameter propeller; to reduce tip speed and provide additional clearance to the aircraft structure and/or ground.

Answer: 1-7

Centrifugal force

Answer: 1-3

high; low

Answer: 1-8

Torque bending force

Answer: 1-4

In the event of an engine failure and during flight training exercises.

Answer: 1-9

Aerodynamic twisting force

Answer: 1-5

high; low

Answer: 1-10

When climbing at a steep angle of attack with the engine operating at a high power setting (eg., takeoff and climb).



PROPELLER

PROPELLER CONSTRUCTION

SUB-MODULE 02

PART-66 SYLLABUS LEVELS

CERTIFICATION CATEGORY –

A B1

Sub-Module 02 PROPELLER CONSTRUCTION Knowledge Requirements

17.2 - Propeller Construction

Construction methods and materials used in wooden, composite and metal propellers;
Blade station, blade face, blade shank, blade back and hub assembly;
Fixed pitch, controllable pitch, constant speed propeller;
Propeller/spinner installation.

1

2

Level 1

A familiarization with the principal elements of the subject.

Objectives:

- (a) The applicant should be familiar with the basic elements of the subject.
- (b) The applicant should be able to give a simple description of the whole subject, using common words and examples.
- (c) The applicant should be able to use typical terms.

Level 2

A general knowledge of the theoretical and practical aspects of the subject and an ability to apply that knowledge.

Objectives:

- (a) The applicant should be able to understand the theoretical fundamentals of the subject.
- (b) The applicant should be able to give a general description of the subject using, as appropriate, typical examples.
- (c) The applicant should be able to use mathematical formula in conjunction with physical laws describing the subject.
- (d) The applicant should be able to read and understand sketches, drawings and schematics describing the subject.
- (e) The applicant should be able to apply his knowledge in a practical manner using detailed procedures.

PROPELLER CONSTRUCTION

PROPELLERS USED ON GENERAL AVIATION AIRCRAFT

An increasing number of light aircraft are designed for operation with governor regulated, constant-speed propellers. Significant segments of general aviation aircraft are still operated with fixed-pitch propellers. A majority of small, single engine aircraft use fixed-pitch metal propellers. Some light sport aircraft (LSA) use multi blade fixed-pitch composite propellers. Medium size turbo prop aircraft will often be equipped controllable propellers with pitch reversing systems. Larger transport and cargo turbo prop aircraft use propeller systems with dual or double acting governors and differential oil pressure to change pitch.

FIXED-PITCH WOODEN PROPELLERS

Although many of the wood propellers were used on older airplanes, some are still in use. Early aviation pioneers carved propellers from laminated wooden blanks using hand tools. The construction of a fixed-pitch, wooden propeller is such that its blade pitch cannot be changed after manufacture. (*Figure 2-1*) The choice of the blade angle is decided by the normal use of the propeller on an aircraft during level flight when the engine performs in an efficient manner. The impossibility of changing the blade pitch on the fixed-pitch propeller restricts its use to small aircraft with low horsepower engines in which maximum engine efficiency during all flight conditions is of lesser significance than in larger aircraft. The wooden, fixed-pitch propeller is well suited for small aircraft because of its lightweight, rigidity, economy of production, simplicity of construction, and ease of replacement. Because many small aircraft have a variety of approved

propellers for installation, aircraft owners or operators have the option of selecting the appropriate propeller for their operation. The two common options are a “climb prop” or “cruise prop.” Climb propellers generally have a lower pitch or shorter diameter that allows the engine to attain higher rpms while cruise propellers are built with higher pitch angles and longer diameters and are well suited for cruise operations.

A wooden propeller is not constructed from a solid block of wood, but is built up of a number of separate layers or laminates of carefully selected and well seasoned hardwoods. Many woods, such as mahogany, cherry, black walnut and oak, are used to some extent, but birch is the most widely used. Five to nine separate layers are typically used, each about 3/4 inch (2 cm) thick. Generally, the growth rings of the laminates are alternated in terms of direction to minimize warping. The wood laminates are glued together using a waterproof, resinous glue and allowed to set. The blank is then roughed out to the approximate shape and size of the finished product. The roughed out propeller is then allowed to dry for approximately one week to permit the moisture content of the layers to become equalized. This additional period of seasoning prevents warping and cracking that might occur if it was immediately carved from a blank. Following this period, the propeller is carefully constructed. Templates and bench protractors are used to assure the proper contour and blade angle at all stations.

After the propeller blades are finished, a fabric covering is cemented to the outer 12 to 15 inches (30 to 38 cm) of each finished blade. A metal or composite tipping is fastened to the leading edge and tip of each blade to protect the propeller from damage caused by flying particles in the

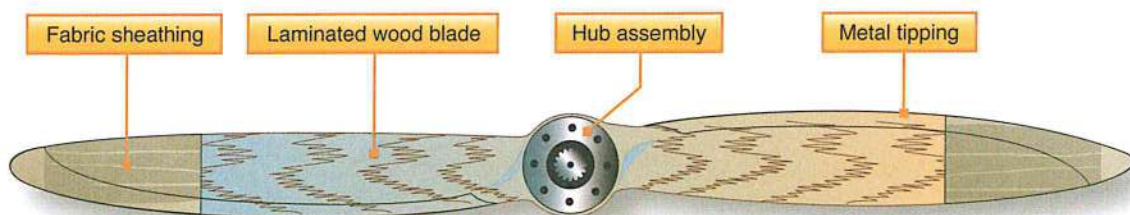

Figure 2-1. Wooden propeller.



Figure 2-2. Propeller data. This propeller has a 72-inch diameter with a 44-inch pitch. It could serve as a climb propeller on some airplanes and a cruise propeller on others. Note the laminates.



Figure 2-3. Wooden propeller showing spinner, hub, laminates, metal tipping, fabric covering, and drain holes.

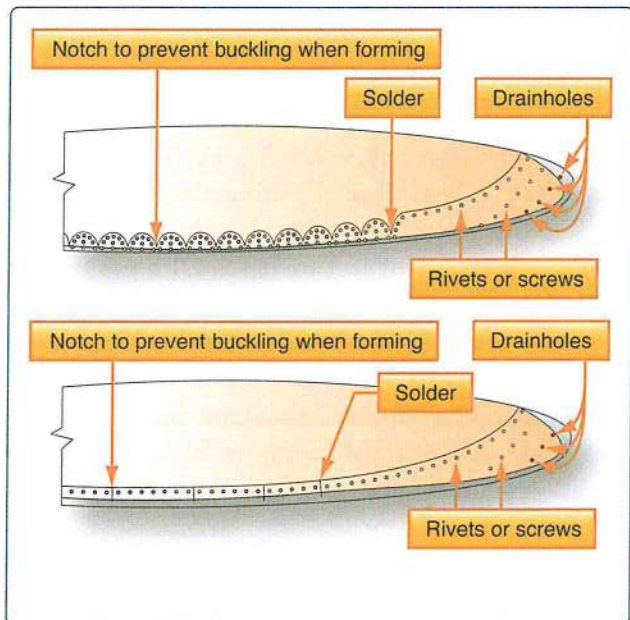

Figure 2-4. Wooden propeller tipping.

air during landing, taxiing, or takeoff. The tipping also serves as an erosion strip to protect the leading edge of the propeller. (Figures 2-3 and 2-4) Metal tipping may be of terneplate, monel metal, or brass. Stainless steel has been used to some extent. The metal tipping is secured

to the leading edge of the blade by countersunk wood screws and rivets. The heads of the screws are soldered to the tipping to prevent loosening, and the solder is filed to make a smooth surface. Since moisture condenses on the tipping between the metal and the wood, the tipping is provided with small holes near the blade tip to allow this moisture to drain away or be thrown out by centrifugal force. (Figure 2-5) It is important that these drain holes be kept open at all times. When the aircraft is inactive for an extended period, the engine is positioned so that the wooden propeller remains in a horizontal position to maintain even water content between the blades. If the blades are left in a vertical position for a protracted period, water in the wood will tend to migrate to the lower blade.

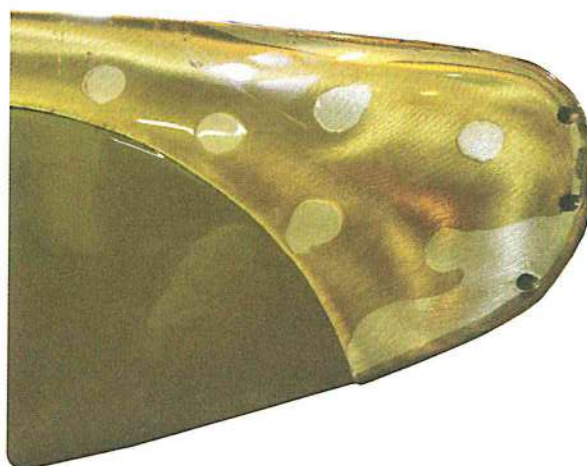

Figure 2-5. Tip on wooden propeller revealing soldered attachment hardware and drain holes.

Since wood is subject to swelling, shrinking, and warping because of changes of moisture content, a protective coating is applied to the finished propeller to prevent a rapid change of moisture content. The finish most commonly used is a number of coats of water repellent, clear varnish. After these processes are completed, the propeller is mounted on a spindle and very carefully balanced.

Several types of hubs are used to mount wooden propellers on the engine crankshaft. The propeller may have a forged steel hub that fits a splined crankshaft. It may be connected to a tapered crankshaft by a tapered, forged steel hub. Or it may be bolted to a steel flange forged on the crankshaft. In any case, several attaching parts are required to mount the propeller on the shaft properly.

Hubs fitting a tapered shaft are usually held in place by a retaining nut that screws onto the end of the crankshaft. A lengthy metal key is used to align the propeller hub with the crankshaft. Proper positioning of the propeller on the crankshaft in terms of clock angle is needed when the engine is started by hand cranking or propping. A snap ring is used in many hubs. The snap ring retains the crankshaft nut when the propeller is removed from the engine. The snap ring also serves as a pulling surface when breaking the hub free from the tapered crankshaft using the crankshaft nut. A loud cracking sound is emitted when the hub is broken free from the tapered crankshaft.

On splined shaft installations, front and rear cones may be used to accurately center the propeller on the crankshaft or propeller shaft and seat the propeller. The rear cone is a one piece bronze design that fits around the shaft and against the thrust nut (or spacer) and seats in the rear cone recess of the hub. The front cone is a two piece, split type steel cone that has a groove around its inner circumference so that it can be fitted over a flange of the propeller retaining nut. Then, the retaining nut is threaded into place and the front cone seats in the front cone hub. A snap ring is fitted into a groove in the hub in front of the front cone so that when the retaining nut is unscrewed from the propeller shaft, the front cone acts against the snap ring and pulls the propeller from the shaft.

One type of hub incorporates a bronze bushing instead of a front cone. When this type of hub is used, it may be necessary to use a puller to start the propeller from the shaft. A rear cone spacer is sometimes provided with the splined shaft propeller assembly to prevent the propeller from interfering with the engine cowling. The wide flange on the rear face of some types of hubs eliminates the use of a rear cone spacer.

One type of hub assembly for the fixed-pitch, wooden propeller is a steel fitting inserted in the propeller to mount it on the propeller shaft. It has two main parts: the faceplate and the flange plate. (*Figure 2-6*) The faceplate is a steel disk that forms the forward face of the hub. The flange plate is a steel flange with an internal bore splined to receive the propeller shaft. The end of the flange plate opposite the flange disk is externally splined to receive the faceplate. The faceplate bore has splines to match these external splines. The units used on lower horsepower engines with tapered shafts generally do not have these splines. Both faceplate and flange plates have

a corresponding series of holes drilled on the disk surface concentric with the hub center. The bore of the flange plate has a 15° cone seat on the rear end and a 30° cone seat on the forward end to center the hub accurately on the propeller shaft.

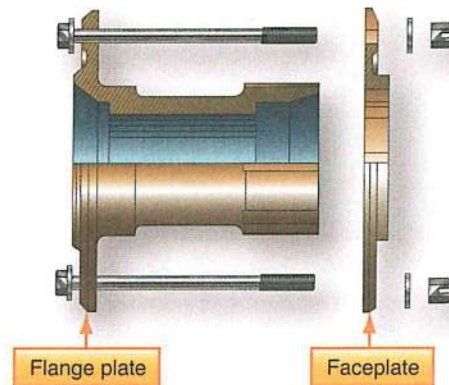

Figure 2-6. Wooden propeller hub adapter.

TORQUING WOODEN PROPELLERS

As with other examples of maintenance procedures provided in this unit, the information contained herein is only for instructional purposes. Always refer to the current manufacturer's technical data for explicit maintenance instructions.

The installation of a wooden propeller must adhere to strict torquing procedures. The torque placed on a wooden propeller must be enough to apply a compressive force to the hub without crushing the wood. Before installing the propeller, or checking the torque, ensure that the magneto switch(es) are in the OFF position and that the aircraft is chocked or tied-down. Removing a spark plug from each cylinder will further enhance safety and will make it easier to rotate the engine for torquing purposes and for checking propeller track. Always use an accurate torque wrench that fulfills calibration requirements.

The propeller bolts should be tightened using a star pattern. Increase the tightness of the bolts using small incremental increases of torque. Keep shifting from one bolt to the next using the star pattern. Continue the process until the prescribed torque value is attained. If self-locking nuts are used to retain the propeller, add the resistance of the friction of the self-locking mechanism to the published torque value. The reason that the technician should use small incremental

increases in torque to arrive at the desired tightness is that applying large quantities of torque at one time to the bolts may cause the wood to crush and the blade track to shift. Wooden propellers should have a blade track no greater than 1/8 inch (3.175 mm). After arriving at the proper torque, safety the propeller retention hardware, as required.

The torque of the propeller bolts should be re-checked after the initial flight and following the first 25 hours of operation. Thereafter, check the bolt torque every 50 hours of operation. The torque should also be checked when the ambient environment changes in a substantial manner (e.g., winter to summer).

To check the torque of the propeller bolts, remove safety wire, if applicable, and rotate the torque wrench in a tightening direction until the fastener begins to turn. If the amount of torque required to rotate the fastener is very low (e.g., approximately half to two-thirds of the prescribed torque), remove the propeller and inspect the hub area for defects (e.g., elongated holes and/or cracks). Such damage must be repaired by the manufacturer or an appropriately rated repair facility. If the torque is somewhat low (e.g., three quarters the specified torque), carefully increase the torque to the proper level. If the torque is within the specified range, no action is required. And if the torque exceeds the prescribed range, loosen the bolts and torque to the correct limit. At the conclusion of the torque check, verify that the propeller track is within limits and resafety the hardware, as necessary.

METAL FIXED-PITCH PROPELLERS

Metal fixed-pitch propellers are similar in general appearance to a wooden propeller, except that the sections are usually thinner. The metal fixed-pitch propeller is widely used on many models of light aircraft. Many of the earliest metal propellers were manufactured in one piece of forged Duralumin. Compared to wooden propellers, some were lighter in weight because of elimination of blade clamping devices, offered a lower maintenance cost because they were made in one piece, provided more efficient cooling because of the effective pitch nearer the hub and, because there was no joint between the blades and the hub, the propeller pitch could be changed, within limits, by twisting the blade slightly by a propeller repair station. Generally, metal propellers are heavier than their wooden counterparts.

Propellers of this type are now manufactured as one piece anodized aluminum alloy. They are identified by stamping the propeller hub with the serial number, model number, type certificate number, production certificate number, and the number of times the propeller has been reconditioned. The complete model number of the propeller is a combination of the basic model number and suffix numbers to indicate the propeller diameter and pitch. An explanation of a complete model number, using the McCauley 1B90/CM propeller, is provided in *Figure 2-7*.

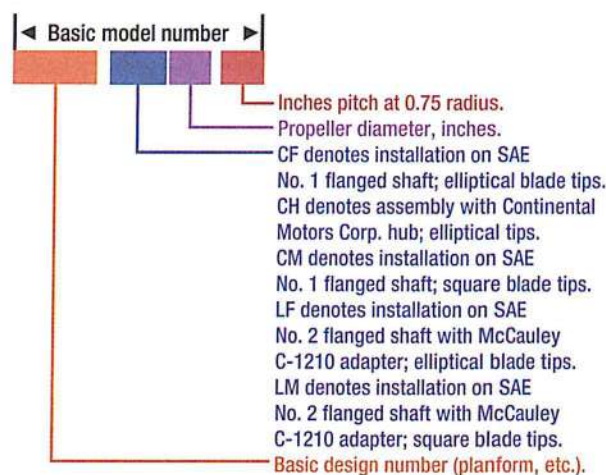

Figure 2-7. Propeller data information.

STEEL PROPELLER BLADES

A number of propeller blades are manufactured from steel. These blades are sometimes found on propellers used on larger aircraft. A number of World War II aircraft and large transport piston powered aircraft of that era use propellers with steel blades.

Steel propeller blades are typically hollow to keep weight to a minimum. By comparison to blades made from other materials, steel propeller blades possess more heft. (*Figure 2-8*)



Figure 2-8. Cross section of steel propeller blade.

COMPOSITE PROPELLERS

As with other parts of the airplane, composite materials and construction techniques have been adopted by the propeller manufacturers. They offer numerous advantages, especially for higher speed turboprop aircraft. The strength offered by composite blades in conjunction with lightweight and reduced sound levels have proven useful attributes.

Similar to other composites used throughout the aviation industry, two essential components are utilized to produce the blades, the matrix and the fiber material. The former is similar to an epoxy and is used to keep the strands of the fiber in position. The fibers possess considerable tensile strength and provide vigor in terms of blade resiliency. A number of propellers flown in aerobatics are composite because of their lightweight, low inertia, durability, and affordability. (Figure 2-9)

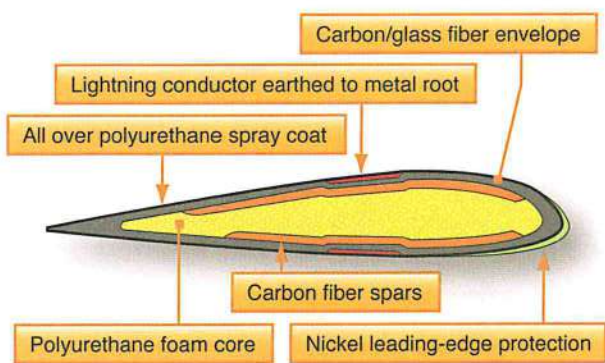

Figure 2-9. Makeup of composite propeller blade.

Composite blades typically begin at the blade root where they are formed around the metal blade shank. Numerous layers of carbon fiber laminates are wound around a core. An attached erosion strip, when included, provides protection against blade erosion. (Figure 2-10)



Figure 2-10. Cross section of composite propeller blade.

BLADE STATIONS

Propeller blades are rotating airfoils that have a relatively complex shape when compared to wings. The main reason for the intricate shape is related to airspeed. Near the propeller hub the relative velocity between the blade section and air is comparatively slow. By contrast, the propeller tip experiences a high velocity with the air. (Figure 1-8) To accommodate the difference in airspeed, a typical propeller blade will have a high blade angle near the hub and a shallow blade angle at the tip. An examination of a propeller blade reveals that the blade angle gradually decreases from the hub or shank area of the blade to the tip. The length of the chord of the propeller blade may also change moving from the hub to the tip. The structural need of the propeller blade near the hub may require a shape that lacks aerodynamic qualities but provides ample strength to combat the various forces placed on the propeller assembly.

Propeller stations are often provided in six inch increments (15 cm). Refer to Figure 1-7. Note the gradual change in pitch angle and chord width.

PROPELLER HUB, SHANK, BACK, AND FACE

The propeller hub is designed to withstand all the forces experienced by the propeller during operation. On fixed-pitched units, the opposing blades connect at the hub, which is a thick, heavily built member. On controllable-pitch propellers, the hub accommodates the pitch change mechanisms, bearings, passageways, and necessary lubricant(s). In addition to retaining the blades and internal members of the pitch control mechanism, the propeller hub is attached to the crankshaft or propeller shaft. The thrust generated by the propeller is transmitted to the engine and ultimately to the airframe through the propeller hub. Some propeller models attach the spinner bulkhead, or spinner backplate, to the hub.

The portion of the blade inserted into the hub of a controllable pitch propeller is known as the blade butt or blade root. The propeller blade shank connects the blade root or butt to the airfoil section of the propeller blade. The shape of the shank ranges from circular or oval to a highly cambered form. The shank must be capable of absorbing the loads placed upon the propeller and transmitting the thrust to the hub. Overshoes or boots associated with de-icing and anti-icing systems are

attached to the shank of the propeller blades and extend down a measure of the blade. (See *Figure 1-2*)

The surface of the propeller blade known as the back is the side of the blade containing the camber or curvature. The propeller back is similar to the upper surface of a wing in that it generates a lower pneumatic pressure as the blade rotates. Where a wing produces lift, the propeller generates thrust.

The face of the propeller blade is the surface that is relatively flat. As the propeller rotates, the face strikes the air. Pilots who fly single engine airplanes equipped with tractor propellers look at, or face, the face of the propeller as they operate the aircraft. (*Figure 2-11*)



Figure 2-12. Club propeller used in test cell.

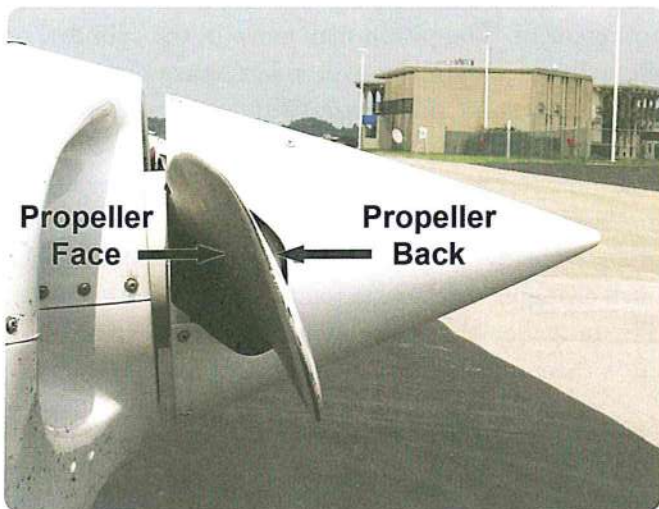

Figure 2-11. Propeller face and back.

FIXED-PITCH PROPELLER

As the name implies, a fixed-pitch propeller has the blade pitch, or blade angle, built into the propeller. (*Figure 2-13*) The blade angle cannot be changed after the propeller is built. Generally, this type of propeller is one piece and is constructed of wood or aluminum alloy.

TYPES OF PROPELLERS

There are various types or classes of propellers, the simplest of which are the fixed-pitch and ground adjustable propellers. The complexity of propeller systems increases from these simpler forms to controllable-pitch and complex constant speed systems (automatic systems). Various characteristics of several propeller types are discussed in the following paragraphs, but no attempt is made to cover all types of propellers.

TEST CLUB PROPELLER

A test club is used to test and break in reciprocating engines. (*Figure 2-12*) They are made to provide the correct amount of load on the engine during the testing and breaking in period and not intended for flight. The multi blade design also provides extra cooling airflow during operation.



Figure 2-13. Fixed-pitch tractor propeller.

Fixed-pitch propellers are designed for best efficiency at one rotational and forward speed. They are designed to fit a set of conditions of both airplane and engine speeds. Any change in these conditions reduces the efficiency of both the propeller and the engine. The fixed-pitch propeller is used on airplanes of low power, speed, range, or altitude. Many single engine aircraft use fixed-pitch propellers and the advantages to these are less expense and their simple operation. This type of propeller does not require any control inputs from the pilot in flight. Fixed-pitch propellers are available in tractor and pusher designs.

GROUND-ADJUSTABLE PROPELLER

The ground-adjustable propeller operates as a fixed-pitch propeller. The pitch, or blade angle, can be changed only when the propeller is not turning. This is done by loosening the clamping mechanism that holds the blades in place, and setting the desired pitch. After the clamping mechanism has been tightened, the pitch of the blades cannot be changed in flight to meet variable flight requirements. The ground-adjustable propeller is not often used on present day airplanes.

CONTROLLABLE-PITCH PROPELLER

The controllable-pitch propeller permits a change of blade pitch, or angle, while the propeller is rotating. This allows the propeller to assume a blade angle that gives the best performance for particular flight conditions. The number of pitch positions may be limited, as with a two position controllable propeller, or the pitch may be adjusted to any angle between the minimum and maximum pitch settings of a given propeller. The use of controllable-pitch propellers also makes it possible to attain the desired engine rpm for a particular flight condition.

This type of propeller is not to be confused with a constant-speed propeller. With the controllable-pitch type, the blade angle can be changed in flight, but the pilot must change the propeller blade angle directly. The blade angle will not change again until the pilot changes it. The electric propellers used on older models Beechcraft Bonanzas are examples of controllable-pitch propellers. To change blade angle on these electric propellers, the pilot toggles increases and decreases in propeller pitch using a switch.

The use of a governor is the next step in the evolution of propeller development, making way for constant-speed propellers with governor systems. Constant-speed propeller systems are commonplace in higher performance general aviation airplanes and larger propeller equipped airplanes.

CONSTANT-SPEED PROPELLERS

The propeller has a natural tendency to slow down as the aircraft climbs and to speed up as the aircraft dives because the load on the engine varies. To provide an efficient propeller, the speed is kept as constant as possible. By using propeller governors to increase or decrease propeller pitch, the engine speed is held constant. When the airplane goes into a climb, the blade angle of the propeller decreases just enough to prevent

the engine speed from decreasing. The engine can maintain its power output if the throttle setting is not changed. When the airplane goes into a dive, the blade angle increases sufficiently to prevent overspeeding and, with the same throttle setting, the power output remains unchanged. If the throttle setting is changed instead of changing the speed of the airplane by climbing or diving, the blade angle increases or decreases as required to maintain a constant engine rpm. The power output (not the rpm) changes in accordance with changes in the throttle setting. The governor controlled, constant-speed propeller changes the blade angle automatically, keeping engine rpm constant.

One type of pitch changing mechanism is operated by oil pressure (hydraulically) and uses a piston and cylinder arrangement. The piston may move in the cylinder, or the cylinder may move over a stationary piston. The linear motion of the piston/cylinder is converted by several different types of mechanical linkages into the rotary motion necessary to change the blade angle. The mechanical connection between the piston/cylinder and propeller blades may be through gears or linkages. The pitch changing mechanism rotates the butt of each blade. The propeller blades are mounted with bearings that allow them to rotate to change pitch. (*Figure 2-14*)



Figure 2-14. Blade bearing locations.

In most cases, the oil pressure for operating the different types of hydraulic pitch changing mechanisms comes directly from the engine lubricating system. When the engine lubricating system is used, the engine oil pressure is usually boosted by a pump that is integral with the governor to operate the propeller. The higher oil pressure (approximately 300 pounds per square inch (psi)) provides a quicker blade angle change. A valve within

the governor directs the pressurized oil for operation of the hydraulic pitch changing mechanism.

The governors used to control hydraulic pitch changing mechanisms are geared to the engine crankshaft and are sensitive to changes in rpm. When rpm increases above the value for which a governor is set, the governor causes the propeller pitch changing mechanism to turn the blades to a higher angle. The higher pitch increases the load on the engine, and rpm decreases until it returns to the on speed rpm. When rpm decreases below the value for which a governor is set, the governor causes the pitch changing mechanism to turn the blades to a lower angle. The load on the engine is decreased and rpm increases until it reaches the on speed rpm. Thus, a propeller governor tends to keep engine rpm constant.

In constant speed propeller systems, the control system automatically adjusts pitch through the use of a governor, without attention by the pilot, to maintain a specific preset engine rpm within the set range of the propeller. For example, if engine speed increases, an overspeed condition occurs and the propeller system responds to reduce the engine rpm. The controls automatically increase the blade angle until the desired rpm has been reestablished. A good constant speed control system responds to such small variations of rpm that for all practical purposes, a constant rpm is maintained.

Each constant speed propeller has an opposing force that operates against the oil pressure from the governor. On some models, counterweights mounted on the propeller blades, or associated parts, move the blades in the high pitch direction as the propeller turns. (Figure 2-15) Other forces used to move the blades toward the high pitch direction include air pressure (contained in the front dome), springs, and aerodynamic twisting moment.



Figure 2-15. Propeller blade counterweight.

FEATHERING PROPELLERS

Feathering propellers are typically mounted on multi engine aircraft to reduce propeller drag to a minimum in case of one or more engine failure conditions. A feathering propeller is a constant speed propeller used on multi engine aircraft that has a mechanism to change the pitch to an angle of approximately 90°. (Figure 1-12) A propeller is usually feathered when the engine fails to develop power to turn the propeller. By rotating the propeller blade angle parallel to the line of flight, the drag on the aircraft is greatly reduced. With the blades parallel to the airstream, the propeller stops turning and minimum windmilling, if any, occurs. The blades are held in feather by aerodynamic forces.

Almost all small feathering propellers use oil pressure to take the propeller to low pitch and blade flyweights, springs, and compressed air to take the blades to high pitch. Since the blades would go to the feather position during shutdown, latches lock the propeller in the low pitch position as the propeller slows down at shutdown. (Figure 2-16) These can be internal or external and are contained within the propeller hub. In flight, the latches are prevented from stopping the blades from feathering because they are held off their seat by centrifugal force. Latches are needed to prevent excess load on the engine at start up. If the blade were in the feathered position during engine start, the engine would be placed under an undue load during a time when the engine is already subject to wear.

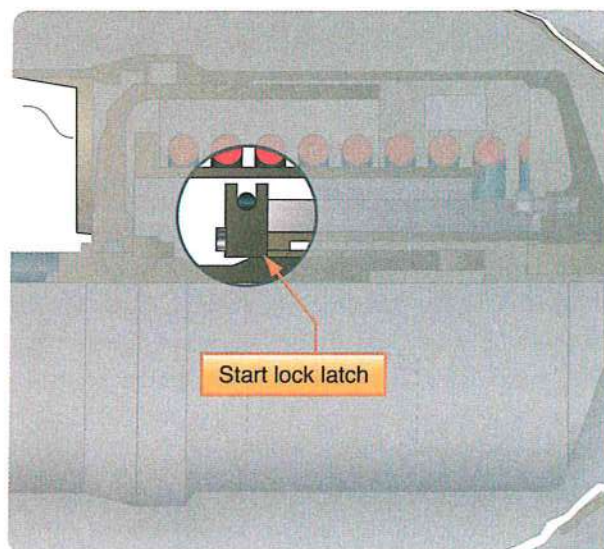

Figure 2-16. Feathering latch.

REVERSE-PITCH PROPELLERS

Additional refinements, such as reverse-pitch propellers (mainly used on turboprop aircraft), are included in some propellers to improve their operational characteristics. Almost all reverse-pitch propellers are of the feathering type. A reverse-pitch propeller is a controllable propeller in which the blade angles can be changed to a negative value during operation.

The purpose of the reversible pitch feature is to produce a negative blade angle that produces thrust opposite the normal forward direction. Typically, when the landing gear is in contact with the runway after landing, the propellers blades can be moved to negative pitch (reversed), which creates thrust opposite of the aircraft direction and slows the aircraft. As the propeller blades move into negative pitch, engine power is applied to increase the negative thrust. This aerodynamically brakes the aircraft and reduces ground roll after landing. The angle of attack encountered by the blades change as the aircraft speed changes. Reversing the propellers also reduces aircraft speed quickly on the runway just after touchdown and minimizes aircraft brake wear. Some aircraft are able to backup using reverse-pitch propellers.

PROPELLER LOCATION

TRACTOR PROPELLER

Tractor propellers are those mounted on the upstream end of a propeller shaft in front of the supporting structure. Most aircraft are equipped with this type of propeller. A major advantage of the tractor propeller is that lower stresses are induced in the propeller as it rotates in relatively undisturbed air. See *Figure 2-13* for an example of a tractor propeller.

PUSHER PROPELLERS

Pusher propellers are those mounted on the downstream end of a propeller shaft behind the supporting structure. Pusher propellers are constructed as fixed or variable pitch units. In the early era of aviation, many airplanes used pusher propellers. Some light sport aircraft use pusher propellers. By placing the propeller behind the wing, airflow over the wing is straight and basically void of the spinning air mass.

Seaplanes and amphibious aircraft have used a greater percentage of pusher propellers than other kinds of aircraft. On land airplanes, where propeller to ground clearance usually is less than the propeller to water

clearance of watercraft, pusher propellers are subject to more damage than tractor propellers. Rocks, gravel, and small objects dislodged by the wheels are quite often thrown or drawn into a pusher propeller. Similarly, planes with pusher propellers are apt to encounter propeller damage from water spray thrown up by the hull during landing or takeoff airspeed. Consequently, the pusher propeller is commonly mounted above and behind the wings to prevent such damage. (*Figure 2-17*)



Figure 2-17. Pusher propeller.

CONTRA-ROTATING PROPELLERS

Contra-rotating propellers are used on a limited number of airplanes. The propellers are mounted on two concentric shafts that rotate in opposite directions. Such installations have little torque effect generated by the propellers as the torque from one unit is largely negated by the torque from the other propeller.



Figure 2-18. Contra-rotating propellers.

Having a contra-rotating propeller installation reduces the diameter of the propeller disc that would otherwise be necessary using a single propeller. This serves to lower the height of the landing gear and airplane in general. (Figure 2-18)

COUNTER-ROTATING PROPELLERS

The Wright Brothers used the counter-rotating design in their early model airplanes to eliminate the torque effect of the spinning propeller mass. Not knowing how much impact the torque effect would have on their aspirations to succeed in producing a successful flying machine, the Brothers decided to cancel the effect by spinning each pusher propeller in opposite directions. (Figure 2-19)



Figure 2-19. Counter-rotating propellers.

Today the installation of counter-rotating propellers is used on certain model multiengine aircraft. The benefit of the counter-rotating design is especially beneficial on twin engine aircraft. When an engine fails or is unable to produce power on a twin engine aircraft, the pilot has to implement compensating action to sustain aircraft altitude and maintain steering. One action is to feather the propeller. This reduces drag on the side of the aircraft with the troubled engine. Next the pilot must input corrective rudder action. Twin engine aircraft with similar rotation propellers will typically possess asymmetrical yaw between the engines. In other words, there will be a greater yawing action when one engine fails than the other. With clockwise rotating propellers, there will be a greater yawing action when the left engine fails. Consequently, the pilot needs to input greater amounts of rudder and rudder trim to compensate for a failed left engine than for a failed right engine. In such cases, the left engine is termed the “critical engine.” A benefit of having counter-rotating propellers is the elimination of the “critical engine” from the aircraft. The critical engine of a multiengine aircraft is defined as the engine whose failure would most adversely affect the performance or handling qualities of an aircraft.

PROPELLER REMOVAL AND INSTALLATION

REMOVAL

The following procedure is for educational purposes only. It provides general steps for removing and reinstalling a propeller on a flanged crankshaft or propeller shaft. Procedures for removing and installing propellers on splined shafts or tapered shafts are different. Always use the current manufacturer’s information when removing and installing any propeller. Exercise caution when handling propellers to prevent damage to the propeller and associated components.

1. Remove the spinner dome in accordance with applicable procedures. It may be necessary to index the spinner prior to removal so that the spinner may be installed in the same relative position with the propeller to maintain pre removal balance.
2. Support the propeller assembly with a sling. If the same propeller is to be reinstalled and has been previously dynamically balanced, make an identifying mark (with a felt tipped pen only) on the propeller hub and a matching mark on the engine flange or propeller shaft to make sure of proper orientation during reinstallation to minimize dynamic imbalance.
3. Remove the lockwire and/or safetying devices. Use caution to prevent scratching the propeller during the removal of the lockwire. Remove the hardware securing the propeller to the shaft. It may be necessary to use special wrenches. Do not allow the tools to damage the crankshaft, engine case, or propeller.

CAUTION: Remove the propeller from the mounting flange with care to prevent damaging the propeller mounting studs. Using the support sling, remove the propeller from the engine. Smaller propellers may be removed without a sling using technicians to grapple with the unit. On constant-speed propeller models, be prepared to capture oil that will drain as the propeller is separated from the propeller shaft.

4. Place the propeller on a suitable cart or fixture for transport or storage.

INSTALLATION

Most flanged propellers have six studs configured in a four inch circle. Dowel pins may also be used to absorb torque during operation and index the propeller with respect to the propeller shaft. Perform the applicable steps to clean the engine flange and propeller flange with quick drying stoddard solvent or methyl-ethyl ketone (MEK). Observe safety precautions when handling such chemicals. Install the O-ring in the O-ring groove in the hub bore or on propeller shaft. **NOTE:** When the propeller is received from the factory, the O-ring has usually been installed or is included with the shipment. With a suitable support, such as a crane hoist or similar equipment or adequate personnel, carefully move the propeller assembly to the engine mounting flange in preparation for installation.

Install the propeller on the engine flange. Make certain to align the dowel pins, if used, with the corresponding holes in the engine mounting flange. As the attachment studs are longer than the dowel pins, exercise care when threading the studs through the mounting holes to avoid damage to the threads. The propeller may be installed on the engine flange in a given position, or 180° from that position. If reinstalling a propeller that has been dynamically balanced, align the propeller to match the original installation position. Check the engine and airframe manuals to determine if either manual specifies a propeller mounting position. (*Figure 2-20*)

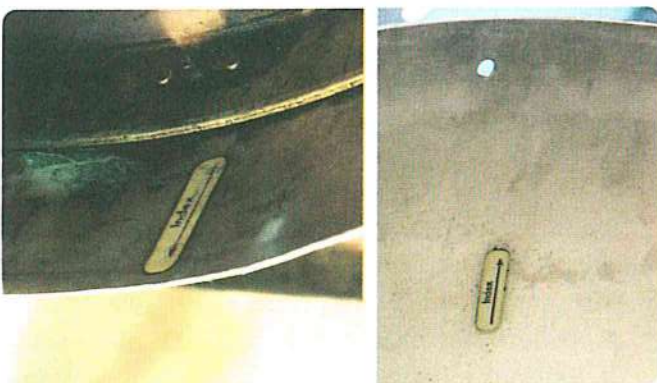

Figure 2-20. Index mark on spinner bulkhead shown on left image and index mark on spinner shown on right image. Technicians should align the two marks before installing the spinner.

CAUTION: Tighten nuts evenly to avoid hub damage.

Install the propeller mounting hardware per manufacturer's instructions. Torque the propeller mounting nuts or bolts in accordance with the proper specifications and safety wire the studs or bolts in pairs (if required by the aircraft maintenance manual). If safety wire is not used, install the appropriate safetying device. Be careful to prevent slippage of wrenches during the torquing process.

Following the installation of the propeller, the technician must connect any additional items included with the propeller system, such as wires for the propeller de-icing system. If equipped, the spinner must be installed. Spinners range from small simple units retained by a single screw, as shown on the wooden propeller in *Figure 2-3* to large spinners. As spinners are part of the rotating mass during operation, technicians should index the spinner in relation to the spinner bulkhead so that during reinstallation the two may be reunited in the same relative position. Some manufacturers index the spinner and bulkhead at the factory. Often technicians will have to install their own index marks (e.g., a piece of tape that spans the spinner and bulkhead). Reinstalling the spinner in a different position may result in vibration during operation.

It will be necessary to perform a post installation test of the propeller. During the test the technician should ensure proper rpm attainment and, if the propeller is controllable, check operation including feathering and reversing, as appropriate. After the test, the technician should check for oil leaks on controllable-pitch models and correct any defects. Next, the technician should complete the appropriate paperwork.

PROPELLER CLEARANCES

During operation, the whirling propeller is capable of causing damage to itself, the engine, and surrounding objects. Generally, when the aircraft experiences a propeller strike, the propeller and engines will need to be inspected and repaired. In extreme cases, the engine and propeller will need to be replaced. To minimize the risk of encountering propeller strikes, an array of clearances between the propeller, ground, water, and structure has been established.

Each set of regulations will specify the appropriate propeller clearances. In the U.S., the minimum clearance between the tip of the propeller and ground is seven inches (18 cm) for nose wheel aircraft and nine inches (23 cm) for tail wheel aircraft. These clearances are when the aircraft is in its normal takeoff or taxiing attitude, whichever is most critical. Aft mounted propellers must be designed so that the propeller will not contact the ground when the airplane is at its maximum pitch attitude during normal takeoffs and landings. There is a requirement of at least 18 inches (46 cm) of clearance between the propeller and water on aircraft that land and takeoff from the water. A requirement of at least one inch (2.54 cm) of clearance in a radial direction is required from the tip of the propeller to the structure of the aircraft. Additional radial clearance may be required to prevent detrimental vibrations. There must be a minimum of $\frac{1}{2}$ inch (1.27 cm) clearance between any part of the propeller blade and any stationary part of the aircraft. Positive clearance between the rotating parts of the propeller and spinner and stationary parts of the airplane is required.

QUESTIONS

Question: 2-1

Name five advantages of fixed pitch wooden propellers.

Question: 2-5

On a test club propeller, what aspect of its design serves to control the maximum rpm of the engine being tested?

Question: 2-2

What is an easy and routine method of preserving the balance of a wood propeller?

Question: 2-6

An airplane is equipped with contra-rotating propellers. Name two advantages to this installation.

Question: 2-3

What is meant by saying that a propeller has a 44 inch pitch?

Question: 2-7

What typically prevents a reversible thrust propeller from engaging a negative pitch setting when in flight?

Question: 2-4

Name the four pieces of information which can be determined by a propeller's model number.

Question: 2-8

On a multi engine aircraft with counter-rotating props, which engine is considered the critical engine?

ANSWERS

Answer: 2-1

Light weight; inexpensive; simplicity; good rigidity; ease of replacement (and not subject to vibration spectrum as discussed in Chapter 6).

Answer: 2-5

The test club's pitch.

Answer: 2-2

Rotate or store it in a horizontal position when not in use.

Answer: 2-6

Eliminates torque induced from P-factor; reduces required propeller diameter.

Answer: 2-3

The propeller will drive the airplane forward by 44 inches with each revolution.

Answer: 2-7

A weight on wheels sensor on the landing gear.

Answer: 2-4

Basic design number; installation data; propeller diameter; propeller pitch.

Answer: 2-8

Neither. Counter rotating props eliminate the problem of "critical engines".

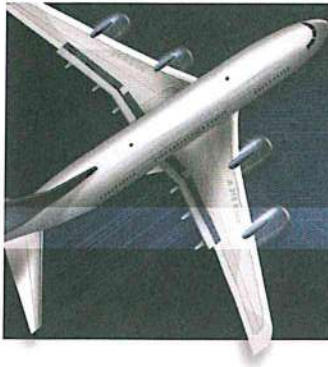

PROPELLER

PROPELLER PITCH CONTROL

SUB-MODULE 03

PART-66 SYLLABUS LEVELS

CERTIFICATION CATEGORY →

| A | B1 |
|---|----|
| 1 | 2 |

PROPELLER PITCH CONTROL

Sub-Module 03 PROPELLER PITCH CONTROL Knowledge Requirements

17.3 - Propeller Pitch Control

- Speed control and pitch change methods, mechanical and electrical/electronic;
- Feathering and reverse pitch;
- Overspeed protection.

Level 1

A familiarization with the principal elements of the subject.

Objectives:

- (a) The applicant should be familiar with the basic elements of the subject.
- (b) The applicant should be able to give a simple description of the whole subject, using common words and examples.
- (c) The applicant should be able to use typical terms.

Level 2

A general knowledge of the theoretical and practical aspects of the subject and an ability to apply that knowledge.

Objectives:

- (a) The applicant should be able to understand the theoretical fundamentals of the subject.
- (b) The applicant should be able to give a general description of the subject using, as appropriate, typical examples.
- (c) The applicant should be able to use mathematical formula in conjunction with physical laws describing the subject.
- (d) The applicant should be able to read and understand sketches, drawings and schematics describing the subject.
- (e) The applicant should be able to apply his knowledge in a practical manner using detailed procedures.

PROPELLER PITCH CONTROLS

As airplanes evolved in terms of power and capability, one element that added greatly to the performance of the airplane was the controllable-pitch propeller. As previously revealed, fixed-pitch propellers were given blade angles designed to provide acceptable performance during both takeoff and cruise. Ground adjustable propellers were developed that gave the operator the ability to set the propeller pitch prior to flight. These units were not adjustable during flight, but provided the means whereby the pitch could be set to enhance either cruise or takeoff operations. Automatic propellers were developed that changed pitch during flight without any direct input from the pilot. Generally, the automatic propellers provided a lower pitch setting for takeoff and climb and a higher pitch for cruise, but lacked the precise controllability preferred by pilots. Controllable-pitch propellers provided the means whereby the pilot could tailor the pitch of the propeller to best suit the flight based on altitude, speed, engine rpm, economy, etc. Early controllable pitch propellers did not provide constant-speed operations. Electrically controlled propellers made available the option for pilots to select a variety of fixed-pitch positions in addition to constant-speed operations.

Technicians must understand the relationship between propeller pitch, rpm, manifold absolute pressure (MAP), and propeller performance. For any single revolution of the propeller, the amount of air displaced (directionally moved) depends on the blade angle, which determines the quantity or mass of air moved by the propeller. Thus, the blade angle becomes a suitable means of adjusting the load on the propeller that is subsequently transferred to the crankshaft to control engine rpm. If the blade angle is increased, more load is placed on the engine, tending to slow it down unless extra horsepower is applied. For the same throttle setting, a reduction of engine rpm will increase the MAP as less air is pulled from the manifold and consumed by the cylinders.

As an airfoil passes through the air, it produces two forces: lift and drag. In terms of propellers, which are rotating airfoils, the force of lift becomes thrust. Increasing propeller blade angle increases the angle of attack (AoA) and produces more lift (thrust) and drag (torque bending force); this action increases the

horsepower required to turn the propeller at any given rpm. Simply stated, it takes more horsepower to drive a higher pitch propeller at the same rpm than it does to drive a lower pitch propeller, other conditions being equal. Since the engine is still producing the same horsepower at the moment that pitch increases, the engine rpm slows down. If the blade angle is decreased, the propeller speeds up and MAP is reduced as more air is pulled from the manifold in response to the increase in rpm. Thus, engine rpm can readily be controlled by increasing or decreasing the blade angle.

The blade angle is also an excellent method of adjusting the AoA of the propeller. On constant-speed propellers, the blade angle is commonly adjusted to provide the most efficient AoA at all engine and airplane speeds. Lift versus drag curves, which are drawn for propellers as well as wings, indicate that the most efficient AoA is a small one varying from 2° to 4° positive. The actual blade angle necessary to maintain this small AoA varies with the forward speed of the airplane. This is due to a change in the relative wind angle or relative airflow (RAF) applied to the propeller blade, which varies with aircraft speed. Refer to *Figures 1-6 and 1-10*.

Fixed-pitch and ground-adjustable propellers are designed for best efficiency at one rotation and forward speed. In other words, they are designed to fit a given airplane and engine combination at a preferred flight parameter. A propeller may be used that provides the maximum propeller efficiency for one of the following: takeoff, climb, cruising, or high speeds. Any change in these conditions results in lowering the efficiency, to some degree, of both the propeller and the engine. A constant-speed propeller, however, keeps the blade angle adjusted for maximum efficiency for most conditions encountered in flight. During takeoff, when maximum power and thrust are required, the constant-speed propeller is at a low propeller blade angle or pitch. The low blade angle keeps the AoA small and efficient with respect to the relative wind or RAF. At the same time, it allows the propeller to handle a smaller mass of air per revolution. This light load allows the engine to turn at a higher rpm and convert the maximum amount of fuel into heat energy in a given time. The high rpm also creates maximum thrust. Although the mass of air handled per revolution is small, the engine rpm is high, the slipstream velocity (air coming off the propeller) is high, and, with the low airplane speed, the thrust is maximum.

After takeoff, as the speed of the airplane increases, the constant-speed propeller changes to a higher angle or blade pitch. Again, the higher blade angle in combination with the higher airspeed keeps the AoA small and efficient with respect to the RAF. The higher blade angle increases the mass of air handled by the propeller per revolution. This decreases the engine rpm, reducing fuel consumption and engine wear, and keeps thrust at a maximum for that operation.

For climb after takeoff, the power output of the engine is reduced by the pilot to climb power. This is accomplished by decreasing the manifold absolute pressure by reducing the throttle opening and increasing the blade angle to lower the engine rpm using the propeller control. Thus, the torque (horsepower absorbed by the propeller) is reduced to match the reduced power of the engine. The AoA is again kept small by the increase in blade angle and forward speed of the aircraft. The greater mass of air handled per second, in this case, is more than offset by the lower slipstream velocity and the increase in airspeed.

At cruising altitude, when the airplane is in level flight and less power is required than is used in takeoff or climb, engine power is once more reduced by lowering the manifold pressure, leaning the mixture, and increasing the blade angle to decrease the rpm. Again, this reduces torque to match the reduced engine power; for, although the mass of air handled per revolution is greater, it is more than offset by a decrease in slipstream velocity and an increase in airspeed. The AoA is still small because the blade angle has been increased to correspond with the increase in airspeed. Pitch distribution along the span of the propeller blade is due to the twist in the blade from the shank to the blade tip and to the variation in speeds that each section of the blade is traveling. (Figure 1-7) The tip of the blade is traveling much faster than the inner portion of the blade as illustrated in Figure 1-8.

The constant-speed propeller has a propeller control lever, often on the center pedestal between the throttle and the mixture control. (Figure 3-1) Single engine airplanes with constant-speed propellers may use a push-pull cable instead of a lever to control propeller pitch. Such cables are normally equipped with a vernier feature that allows the pilot to precisely set rpm by slowly rotating the control knob in the appropriate direction, clockwise

to increase rpm and counter clockwise to decrease rpm. A release button in the center of the control allows the pilot the ability to rapidly push or pull the propeller control. (Figure 3-2)



Figure 3-1. Throttle; propeller; and mixture controls of twin engine aircraft.

The two extreme positions for the propeller control are increase rpm or low pitch (full forward) and decrease rpm or high pitch (full aft). The propeller knob is directly connected to the propeller governor and, by moving the control, adjusts the tension on the governor speeder spring. On applicable models, this control can also be used to feather the propeller by moving the knob into the feathering position. The two main engine instruments used for setting power with the constant-speed propeller are the tachometer and the manifold pressure gauge. During cruise operations, revolutions per minute (rpm) is controlled by the propeller control and the manifold pressure is set using the throttle control.



Figure 3-2. Push-pull type controls for throttle (T), propeller (P), and mixture (M). Rotating the propeller vernier control clockwise increases the on speed rpm. Pressing the release button in the center of the knob allows the control to be rapidly moved in a linear fashion. Both the propeller and mixture controls are equipped with the vernier feature in this illustration.

PROPELLER GOVERNOR

A propeller governor is an engine rpm sensing device with a high pressure oil pump. In a constant-speed propeller system, the governor responds to a change in engine rpm by directing oil under pressure to the propeller hydraulic cylinder or by releasing oil from the hydraulic cylinder, depending on system design. The change in oil volume in the hydraulic cylinder changes the blade angle and maintains the engine rpm. The governor is set for a specific rpm through the use of the propeller control, which compresses or releases tension on the governor speeder spring. (Figure 3-3)

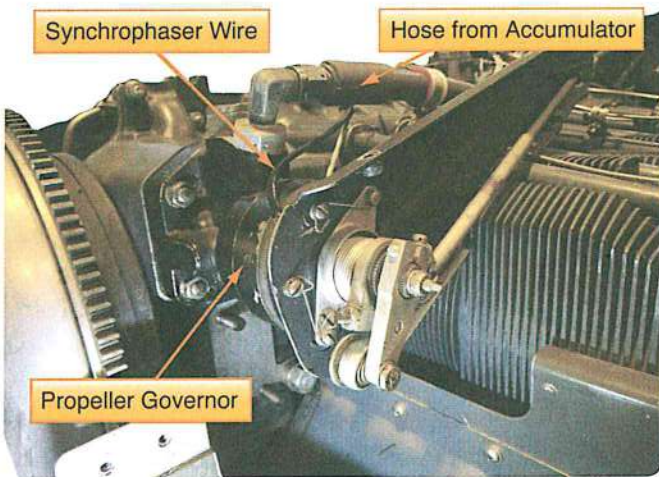

Figure 3-3. Propeller governor equipped with synchronization and synchrophaser system and hose from unfeathering accumulator (note wire and hose attached to the governor).

A propeller governor is used to sense propeller/engine speed and normally provides pressurized oil to the propeller to reduce blade pitch. There are a couple of non feathering propellers that operate opposite to this; they are discussed later in this chapter. Fundamental forces, some already discussed, are used to control blade angle variations required for constant-speed propeller operation. These forces are:

1. Centrifugal twisting moment (CTM) - a component of the centrifugal force acting on a rotating blade that tends at all times to move the blade into low pitch. (Figure 1-14E)
2. Propeller governor oil on the propeller piston side of the governor moves the blades to low pitch. This balances against the propeller blade counterweights. The latter moves the blades toward high pitch.

3. Propeller blade counterweights - always move the blades toward high pitch. (Figure 2-15)
4. Pneumatic pressure against the propeller piston - pushes toward high pitch.
5. Springs - push in the direction of high pitch and feather.
6. Aerodynamic twisting moment (ATM) - moves the blades toward high pitch. (Figure 1-14D)

All of the forces listed are not equal in terms of magnitude. The most powerful force is the governor oil pressure acting on the propeller piston. The piston is connected mechanically to the blades; as the piston moves, the blades are rotated in proportion to change pitch angle. By removing the oil pressure from the governor, the other forces can force the oil from the piston chamber and move the propeller blades in the other direction.

GOVERNOR MECHANISM

The engine driven single acting propeller governor (constant-speed control) receives oil from the engine's lubricating system and boosts that pressure to that required to operate the pitch changing mechanism. (Figure 3-4) It consists of a gear pump to increase the pressure of the input oil from the engine, a pilot valve controlled by flyweights in the governor to direct the flow of oil through the governor to and from the propeller, and a relief valve

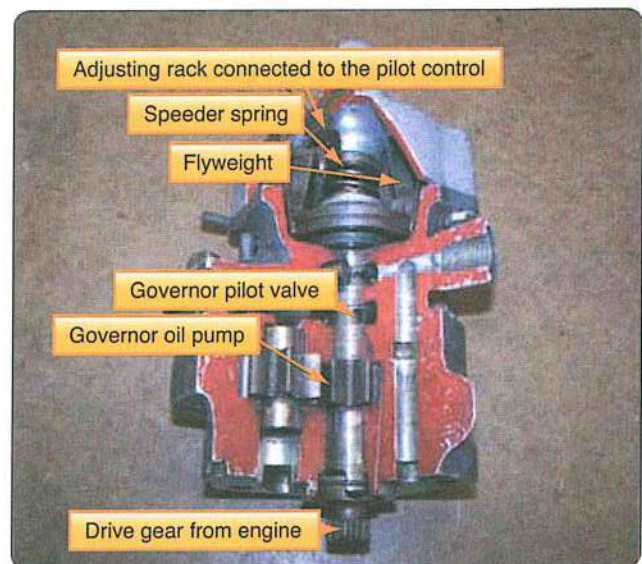

Figure 3-4. Internal workings of a propeller governor.

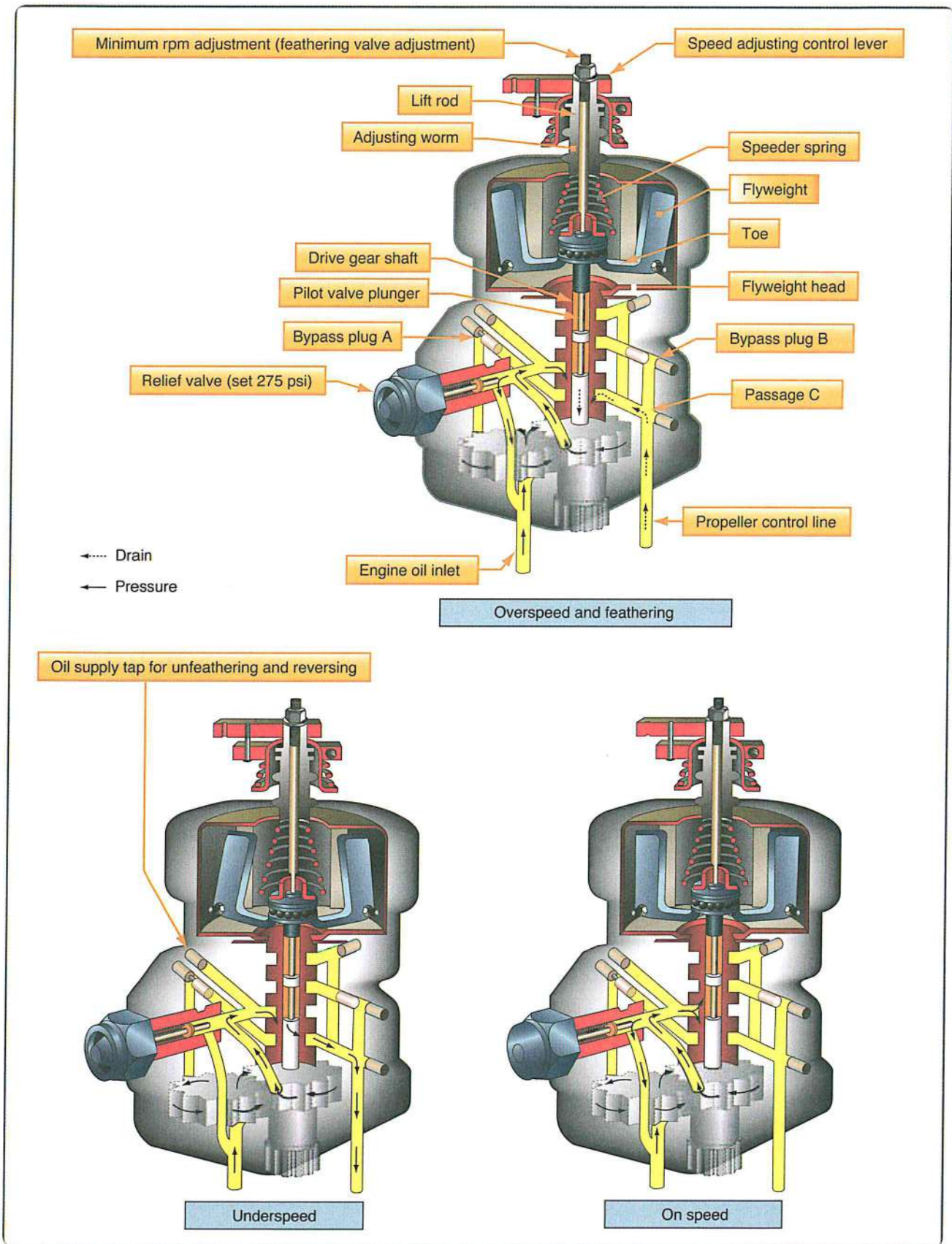

Figure 3-5. Propeller governor in over speed, under speed, and on speed conditions

system that regulates the operating oil pressures in the governor. A spring called the speeder spring opposes the governor flyweight's ability to fly outward when turning. The tension on this spring can be adjusted by moving the propeller control on the control quadrant. The tension of the speeder spring sets the maximum rpm of the engine in the constant-speed mode. As the engine/propeller rpm is increased to the maximum set point (maximum speed) of the governor, the governor flyweights overcome the tension of the speeder spring and move outward. This action moves the pilot valve in the governor to release oil from the propeller piston and allows the counterweights on the propeller blades to increase blade pitch, which increases the load on the engine, slowing it down to return the rpm to the on speed rpm.

In addition to boosting the engine oil pressure to produce one of the fundamental control forces, the governor maintains the required balance between control forces by metering to, or draining from, the propeller piston the exact quantity of oil necessary to maintain the proper blade angle for constant-speed operation. The position of the pilot valve, with respect to the propeller governor metering port, regulates the quantity of oil that flows through this port to or from the propeller.

A speeder spring opposes the action of the governor flyweights which sense propeller speed. If the flyweights turn slower than the tension on the speeder spring, they move inward; this is an under speed condition. To accelerate the engine/propeller combination, the blade angle (pitch) must be decreased. Additional oil flows into the propeller and acts on the piston to decrease blade pitch or blade angle, speeding up the engine until it reaches the on speed condition where the force on the governor flyweights and the tension on the speeder spring are returned to a balanced condition. This balance of forces can be disturbed by the aircraft changing attitude (climb or dive) or the pilot changing the tension on the speeder spring with the propeller control (i.e., if the pilot selects a different rpm) or by the pilot moving the throttle control. (Figure 3-5)

Before discussing the on speed, under speed, and over speed operations it must be mentioned that the propeller governing systems tries to maintain an on speed condition. This is established when the mechanical forces between speeder spring tension and flyweight action are equal. When the engine is running at low

rpm, such as start up, warm up, taxiing, final approach, etc., the governor attempts to lower propeller pitch to elevate engine rpm until the on-speed condition is attained. However, when the propeller blades are against their physical low pitch stops, they are unable to further reduce pitch to gain rpm. In such operating conditions, the propeller acts like a fixed-pitch unit and remains against the low pitch stop until the rpm is increased and the on speed rpm is reached or exceeded. Should the governor encounter an over speed condition, the pilot valve will be shifted within the governor to increase the blade pitch in order to reduce rpm until the on speed condition is established.

ON SPEED CONDITION

When the engine is operating at the rpm set by the pilot using the cockpit control, the governor is operating "on speed." (Figure 3-6) In an on speed condition, the centrifugal force acting on the governor's flyweights is balanced by the tension exerted by the speeder spring, and the pilot valve is neither directing oil to or from the propeller hydraulic cylinder. In the on speed condition, the forces of the governor flyweights and the tension on the speeder spring are equal; the propeller blades are not changing pitch. If something happens to unbalance these forces, such as if the aircraft dives or climbs, or the pilot selects a new rpm range by moving the propeller control (changes tension on the speeder spring), or the pilot changes throttle setting, then these forces are unequal and

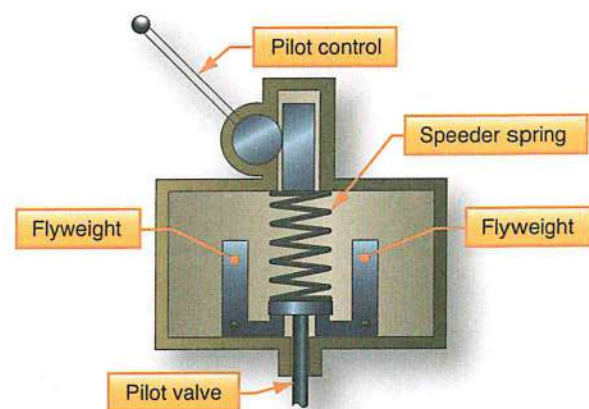

Figure 3-6. Propeller governor in an on speed condition. It should be pointed out that when the governor is installed on the engine, it is adjusted to establish an on speed condition when the engine is operating at redline rpm with the propeller control in the full increase rpm, or low pitch, position. Having the maximum engine rpm adjusted and maintained by the governor reduces the risk of the engine experiencing operations beyond the redline rpm.

an under speed or over speed condition will result. The governor, as a speed sensing device, causes the propeller to respond to under speed and over speed conditions by returning to the set rpm regardless of the aircraft attitude or throttle setting. The speeder spring propeller governing range is limited to about 200 rpm. Beyond this rpm, the governor cannot maintain the correct rpm.

UNDER SPEED CONDITION

When the engine is operating below the rpm set by the pilot using the cockpit control, the governor is operating in an under speed condition. (Figure 3-7) In this condition, the arms of the flyweights tilt inward because there is not enough centrifugal force acting on the flyweights to overcome the force of the speeder spring. The pilot valve, forced down by the speeder spring, meters oil flow to decrease propeller pitch and raise engine rpm. If the nose of the aircraft is raised or the blades are moved to a higher blade angle, this increases the load on the engine and works to reduce rpm. To maintain a constant speed, the governor senses the decrease in speed and increases oil flow to the propeller, moving the blades to a lower pitch and allowing them to maintain the same speed. When the engine speed starts to drop below the rpm for which the governor is set, the resulting decrease in centrifugal force exerted by the flyweights permits the speeder spring to lower the pilot valve (flyweights inward), thereby opening the governor metering port. The oil then flows through the valve port and into the propeller piston causing the blades to move to a lower pitch (a decrease in load).

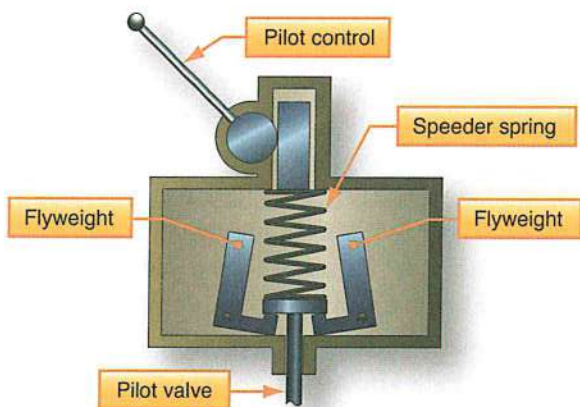

Figure 3-7. Propeller governor in an under speed condition.

Of course the propeller governor will be in an under speed condition when the engine is operated at low power settings. As previously indicated, the governor works to further lower the propeller pitch under such

conditions, but because the propeller blades are against their physical low pitch stops, the governor is unable to increase rpm by further reducing propeller pitch. This occurs whenever the engine rpm is below the operating range of the propeller governor.

OVER SPEED CONDITION

When the engine is operating above the rpm set by the pilot using the cockpit control or the redline adjustment of the governor, the governor is operating in an over speed condition. (Figure 3-8) In an over speed condition, the centrifugal force acting on the flyweights is greater than the speeder spring force. The flyweight arms tilt outward and raise the pilot valve. The pilot valve then meters oil flow to increase propeller pitch and lower engine rpm. When the engine speed increases above the rpm for which the governor is set, note that the flyweights move outward against the force of the speeder spring, raising the pilot valve. This opens the propeller governor metering port, allowing governor oil to flow from the propeller piston. At this point the counterweights on the blades increase pitch angle, which slows the engine rpm.

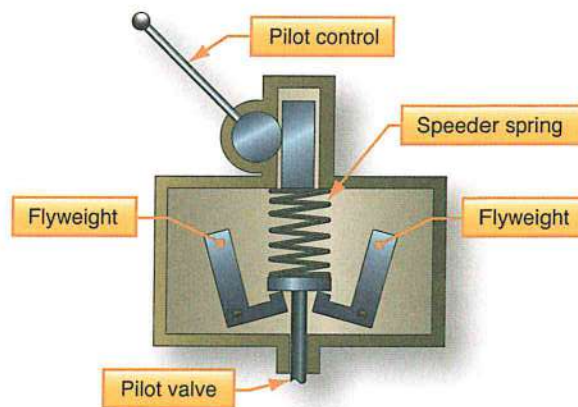

Figure 3-8. Propeller governor in an over speed condition.

CONSTANT-SPEED PROPELLER OPERATIONS

HARTZELL CONSTANT-SPEED, NON-FEATHERING PROPELLERS

Hartzell propellers can be classified by aluminum hub (compact) and steel hub. Hartzell compact aluminum propellers represent new concepts in basic design. They combine low weight and simplicity in design and rugged construction. In order to achieve these ends, the hub is made as compact as possible, utilizing aluminum alloy forgings for most of the parts. The hub shell is made in two halves, bolted together along the plane of rotation.

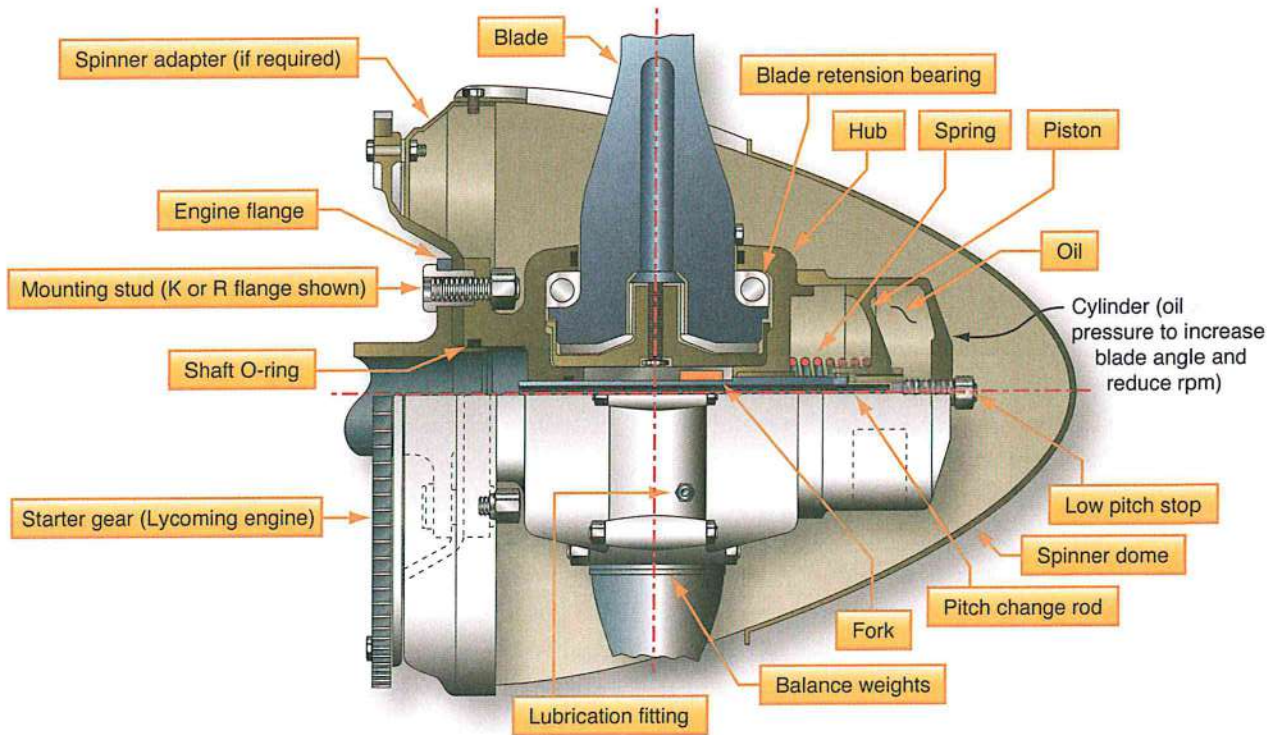

Figure 3-9. Constant speed, non-feathering propeller.

This hub shell carries the pitch change mechanism and blade roots internally. The hydraulic cylinder, which provides power for changing the pitch, is mounted at the front of the hub. The propeller can be installed only on engines with flanged mounting provisions.

One model of non-feathering aluminum hub constant-speed propeller utilizes oil pressure from a governor to move the blades into high pitch (decrease rpm). The centrifugal twisting moment of the blades tends to move them into low pitch (increase rpm) in the absence of governor oil pressure. This is an exception to most of the aluminum hub models and feathering models. Most of the Hartzell aluminum and steel hub models use centrifugal force acting on blade counterweights to increase blade pitch and governor oil pressure for low pitch. Many types of light aircraft use governor regulated, constant-speed propellers in two bladed and up to six bladed versions. These propellers may be the non-feathering type, or they may be capable of feathering and reversing. The steel hub contains a central "spider," that supports aluminum blades with a tube extending inside the blade roots. Blade clamps connect the blade shanks with blade retention bearings. A hydraulic cylinder is mounted on the rotational axis connected to the blade clamps for pitch actuation. (Figure 3-9)

The basic hub and blade retention is common to all models described. The blades are mounted on the hub spider for angular adjustment. The centrifugal force (pulling the blades from the hub) generated by the blades during high rpm operations, amounting to as much as 25 tons, is transmitted to the hub spider through blade clamps and then through bearings. The propeller thrust and engine torque is transmitted from the blades to the hub spider through a bushing inside the blade shank. In order to control the pitch of the blades, a hydraulic piston cylinder element is mounted on the front of the hub spider. The piston is attached to the blade clamps by means of a sliding rod and fork system for non-feathering models and a link system for the feathering models. The piston is actuated in the forward direction by means of oil pressure supplied by a governor, which overcomes the opposing force created by the blade counterweights. Hartzell and McCauley propellers for light aircraft are similar in operation. The manufacturer's specifications and instructions must be consulted for information on specific models.

CONSTANT-SPEED FEATHERING PROPELLERS

The feathering propeller utilizes a single oil supply from a governing device to hydraulically actuate a change

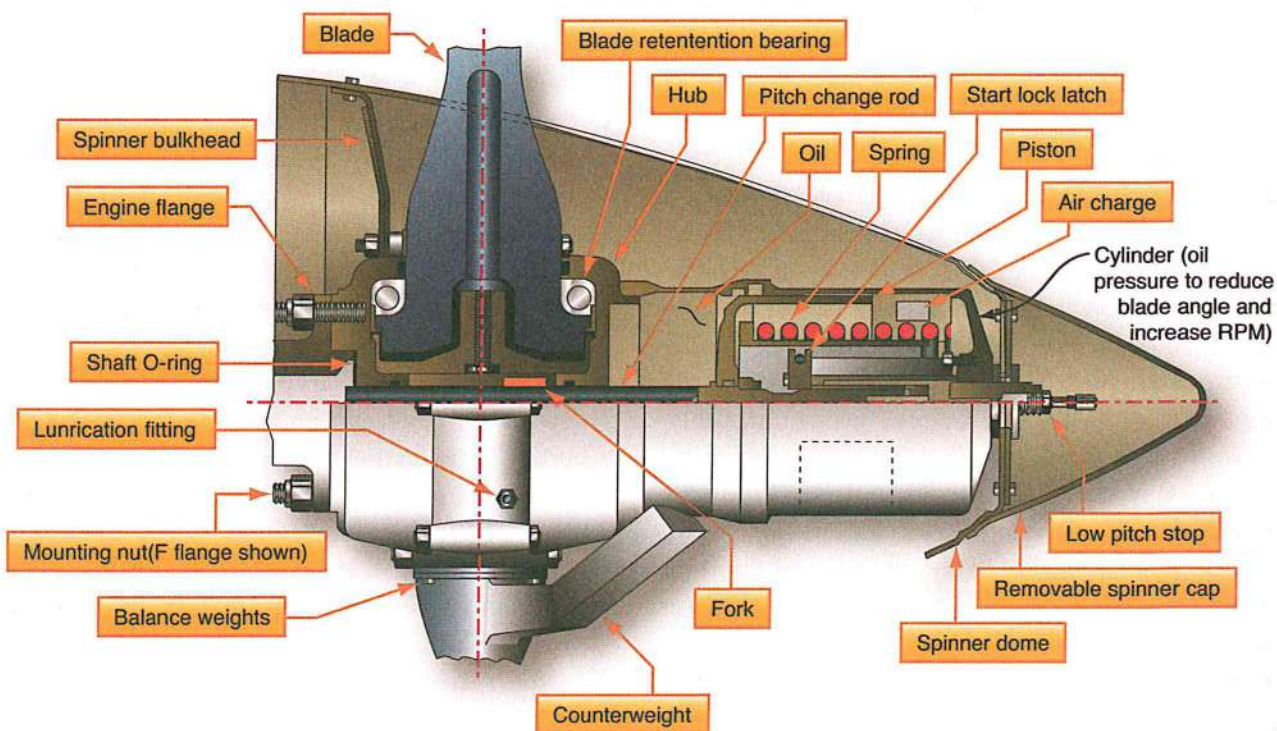

Figure 3-10. Constant speed, feathering propeller.

in blade angle. (Figure 3-10) This propeller has five blades and is used primarily on Pratt and Whitney turboprop engines. A two piece aluminum hub retains each propeller blade on a thrust bearing. A cylinder is attached to the hub and contains a feathering spring and piston. The hydraulically actuated piston transmits linear motion through a pitch change rod and fork to each blade to produce changes in blade angles.

While the propeller is operating, the following forces are constantly present: 1) spring force, 2) propeller blade counterweight force, 3) centrifugal twisting moment (CTM) of each blade, and 4) blade aerodynamic twisting moment (ATM). The spring and counterweight forces attempt to rotate the blades to a higher blade angle, while the centrifugal twisting moment of each blade is generally working to lower blade angle. Blade aerodynamic twisting force is usually very small in relation to the other forces and can attempt to increase or decrease blade angle. The summation of the propeller forces is toward higher pitch and is opposed by a variable force toward lower pitch.

The variable force is oil under pressure from a governor with an internal pump that is mounted on and driven by the engine. The oil from the governor is supplied to the propeller and hydraulic piston through a hollow propeller

shaft. Increasing the volume of oil within the piston and cylinder decreases the blade angle and increases propeller rpm. If governor supplied oil is lost during operation, the propeller increases pitch and feathers. Feathering occurs because the summation of internal propeller forces causes the oil to drain out of the propeller until the feather stop position is reached. Normal inflight feathering is accomplished when the pilot retards the propeller condition lever past the feather detent. This permits control oil to drain from the propeller and return to the engine sump. Engine shutdown is normally accomplished during the feathering process. Normal inflight unfeathering is accomplished when the pilot positions the propeller condition lever into the normal flight (governing) range and restarts the engine. As engine speed increases, the governor supplies oil to the propeller and the blade angle decreases. Decreasing the volume of oil increases blade angle and decrease propeller rpm. By changing blade angle, the governor can vary the load on the engine and maintain constant engine rpm (within limits), independent of where the power lever is set. The governor uses engine speed sensing mechanisms that permit it to supply or drain oil as necessary to maintain constant engine speed (rpm). Most of the steel hub Hartzell propellers and many of the aluminum hub units are full feathering. These feathering propellers

operate similarly to the non-feathering ones except the feathering spring assists the counterweights to increase the pitch of the blades.

As previously stated, feathering is accomplished by releasing the governor oil pressure from the piston assembly, allowing the counterweights and feathering spring to feather the blades. This is done by pulling the condition lever (pitch control) back to the limit of its travel, which opens up a port in the governor allowing the oil from the propeller dome to drain back into the engine. As the oil drains from the piston assembly, the actions of the blade counterweights and feathering spring work to increase propeller pitch. The time necessary to feather depends upon the size of the oil passage from the propeller to the engine, and the force exerted by the spring and counterweights. The larger the passage is through the governor and the heavier the spring, the quicker the feathering action. The force generated by the blade counterweight decreases as the propeller rpm is reduced. An elapsed time for feathering of between three and 10 seconds is common with this system. Engine shutdown is normally accomplished during the feathering process.

In order to prevent the feathering spring from feathering the propeller when the engine is stopped, automatically removable high pitch stops are incorporated in the design. These consist of spring loaded latches fastened to the stationary hub that engage high pitch stop plates bolted to the movable blade clamps. When the propeller is rotating at speeds over 600–800 rpm, centrifugal force acts to disengage the latches from the high pitch stop plates so that the propeller pitch may be increased to the feathering position. At lower rpm, or when the engine is stopped, the latch springs engage the latches with the high pitch stops, preventing the pitch from increasing further despite the action of the feathering spring. As mentioned earlier, the engine load would be excessive, especially on fixed turbine turboprop engines. One safety feature inherent in this method of feathering is that the propeller feathers if the governor oil pressure drops to zero for any reason. As the governor obtains its supply of oil from the engine lubricating system, it follows that if the engine runs out of oil or if oil pressure fails due to breakage of a part of the engine, the propeller feathers automatically. This action may save the engine from further damage in case the pilot is not aware of the fault(s).

UNFEATHERING

Unfeathering can be accomplished by any of several methods, as follows:

1. Start the engine, so the governor can pump oil back into the propeller to reduce pitch. In most light twins, this procedure is considered adequate since the feathering of the propeller rarely occurs, except during flight training. Vibration can occur when the engine starts and the propeller starts to come out of feather.
2. Provide an accumulator connected to the governor with a valve to trap a pneumatic oil charge when the propeller is feathered, but released to the propeller when the propeller or rpm control is returned to normal position. This system is used with training aircraft because it unfeathers the propeller in a very short time and promptly starts the engine windmilling.
3. Provide an unfeathering pump that provides pressure to force the propeller back to low pitch quickly using engine oil.

Normal inflight unfeathering is accomplished when the pilot positions the propeller control lever into the normal flight (governing) range. This causes the governor to disconnect the propeller oil supply from the return drain and reconnects it to the governed oil supply line from the governor. At that instant, there is no oil available from the engine oil pump to the governor because the engine is not rotating; therefore, no governed oil is available from the governor for controlling the propeller blade angle and rpm. As the engine is started, its speed increases, the governor supplies oil to the propeller, and the blade angle decreases. As soon as the engine is operating, the governor starts to unfeather the blades. Soon thereafter, windmilling takes place, which speeds up the process of unfeathering.

In general, restarting and unfeathering of propellers can be classified as reciprocating engine restart unfeathering, turboprop restart unfeathering, and accumulator unfeathering. When reciprocating engine restarting is used to unfeather the propeller, the engine takes a little longer to rotate fast enough to provide oil pressure to the governor and then to the propeller. This delay can cause vibration as the propeller is unfeathered. Many aircraft use an accumulator to provide stored pressure to quickly unfeather the propeller.

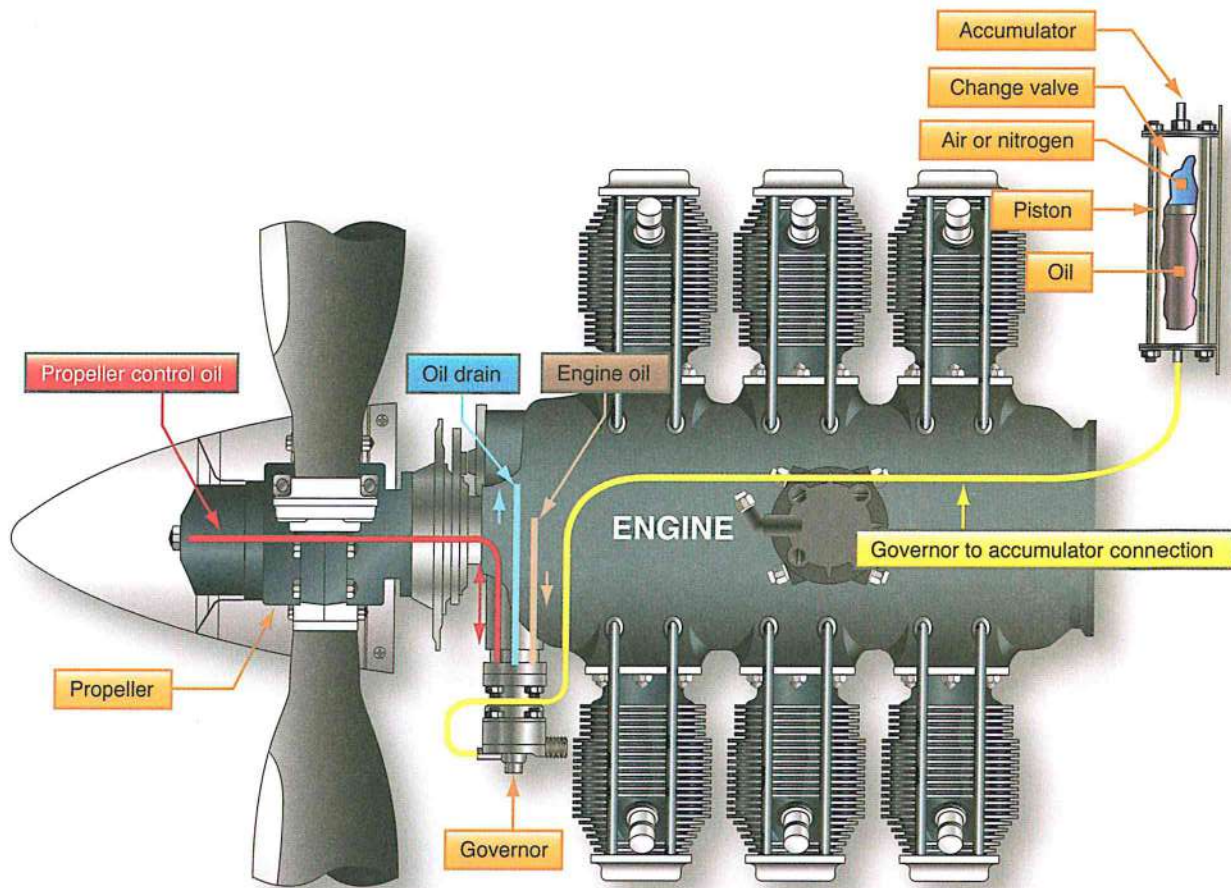

Figure 3-11. Unfeathering accumulator system.

PROPELLER PITCH CONTROL

Special unfeathering systems are available for certain aircraft where restarting the engine is difficult or for training purposes. The system consists of an oil accumulator connected to the governor through a valve. (Figure 3-11) The air or nitrogen pressure in one side of the accumulator pushes a piston to force oil from the other side of the accumulator through the governor to the propeller piston to move the propeller blades from feather to a lower blade angle. The propeller then begins to windmill and permits the engine to start. When an unfeathering pump is used, it is a separate unit that, once the propeller control is in the correct position (full increase rpm), the pump is actuated and the oil pressure from the pump unfeathers the propeller.

AUTOFEATHERING SYSTEM

An autofeather system is used normally only during takeoff, approach, and landing. It feathers the propeller automatically if power is lost from an engine. The system uses a solenoid valve to dump oil pressure from the propeller cylinder (this allows the propeller to feather) if

two torque switches sense low torque from the engine. This system typically has a Test-Off-Arm switch that is used to operate the system.

HAMILTON STANDARD HYDROMATIC PROPELLERS

Hamilton Standard hydromatic propellers (Figure 3-12) are used with older type aircraft dating back to the 1930s, throughout World War II, and later used in aircraft involved in cargo and transport operations up to the jet age. Many hydromatic propellers continue to operate.

Hamilton Standard propellers installed on large aircraft often weigh more than one ton. A hydromatic propeller has a double acting governor that uses oil pressure on both sides of the pitch change piston located in the dome of the propeller hub. Many larger turboprop systems also use this type of system. The hydromatic governors are similar in construction and principle of operation as in other constant speed systems. The major difference is in the pitch changing mechanism. In the hydromatic propeller,

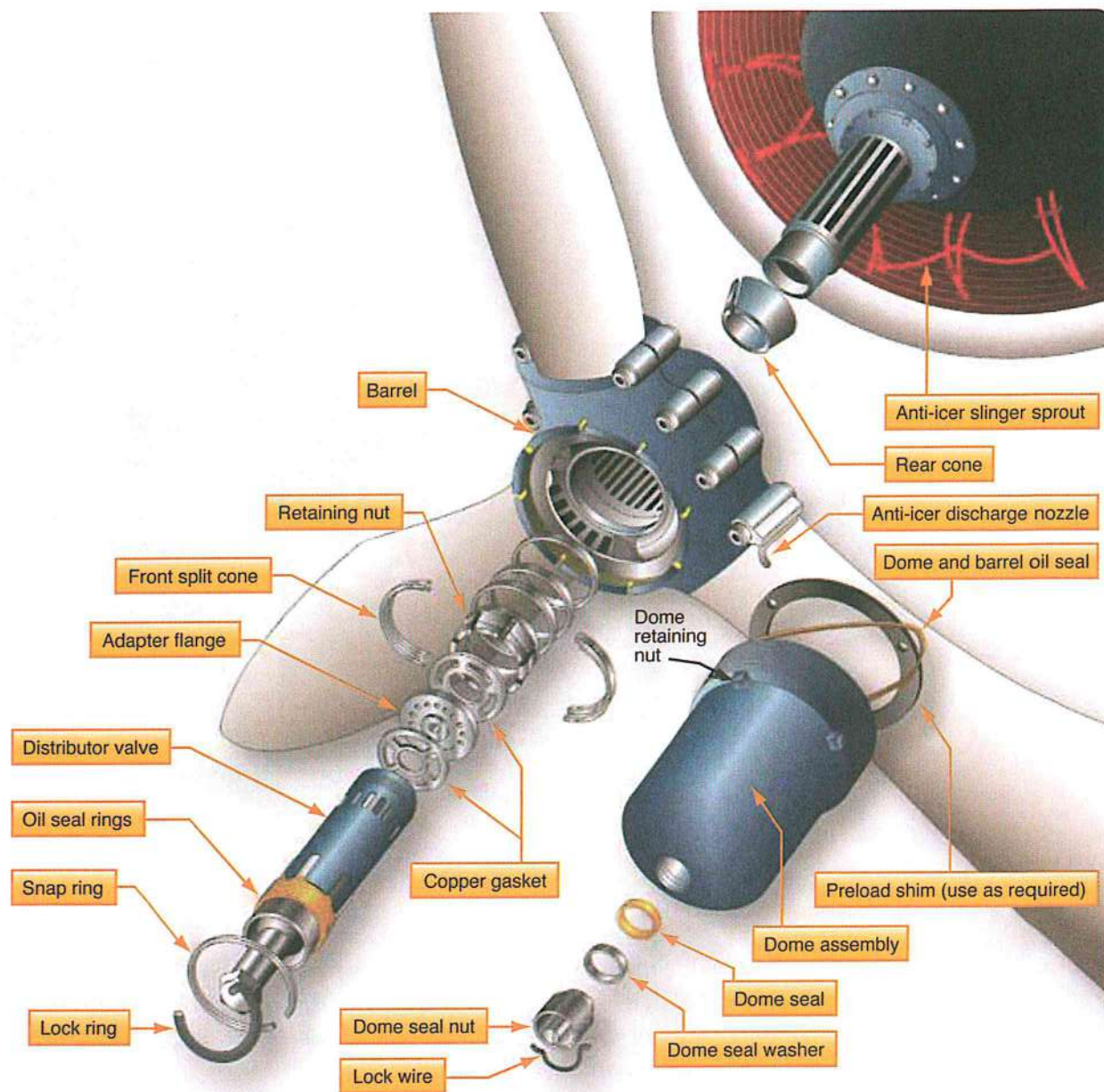

Figure 3-12. Hamilton Standard Hydromatic Propeller.

no counterweights are used on the propeller blades, and the moving parts of the mechanism are completely enclosed. Oil pressure and the centrifugal twisting moment (CTM) of the blades are used together to move the blades to a lower pitch angle. The main advantages of the hydromatic propeller are the large blade angle range and the feathering and reversing features.

This propeller system is a double acting hydraulic propeller design in which the hydraulic pressure (engine oil pressure) on the piston dome is used against governor oil pressure on the opposite side of the piston. These two opposing hydraulic forces are used to control and change

blade angle or pitch. Although hydromatic propeller systems are decades old, some are still used on large reciprocating engines. Larger new turboprop systems also use this opposing hydraulic force and double acting governor systems.

COMPONENTS

The propeller is divided into five major component assemblies: 1) hub, 2) piston and dome, 3) distributor valve, 4) cam and gear assemblies, and 5) propeller blades and associated parts. Control of the propeller is provided by the governor, feathering/unfeathering pump, and associated switches and controls.

The hub of the propeller is the main structural component. It absorbs the thrust, torque, and centrifugal forces encountered during operation. The blades are attached to the hub in a fashion that includes provisions for allowing the blades to change pitch. The hub includes splines that mesh with the splines of the propeller shaft. Cones are used at the rear and forward ends of the hub to precisely center the hub on the propeller shaft. A retention nut affixes the hub to the propeller shaft.

The piston is located in the dome. During operation both sides of the piston are subjected to oil pressures. The side of the piston referred to as the “inboard” section is closest to the engine and the area of the piston known as the “outboard” portion is on the opposite side or the furthest from the engine. During normal operations, the outboard side of the piston senses engine oil pressure and the inboard piston surface receives high pressure oil from the propeller governor.

The distributor valve, or engine shaft extension assembly, provides oil passages for governor oil, or auxiliary oil from the feathering pump, to the inboard side of the piston and for engine oil to the outboard side. It is spring loaded to provide constant-speed and feathering operations. During unfeathering operations, the distributor valve moves when a prescribed level of hydraulic action is met and reverses the passages so that oil from the auxiliary pump flows to the outboard side of the piston and oil on the inboard side of the piston flows back to the engine. The engine shaft extension assembly is used with propellers that do not have feathering capabilities.

The cam and gear assembly is designed to convert the linear travel of the piston to rotary motion that changes propeller blade pitch. The two cylindrical cams are concentric with the stationary cam attached to the piston and the rotating cam geared to the propeller blades. A series of rollers are used to connect the stationary cam with the rotating cam. Specially shaped slots in the cam contain the rollers and provide the translation of linear piston travel to a rotary motion that alters propeller blade pitch. As the piston moves fore and aft, the rollers tracking in the angled slots cause the rotating cam to turn. Beveled gears on the inboard end on the rotating cam mesh with gear teeth on the propeller blade butt.

Propeller blades used on the vintage Hamilton Standard propellers do not employ counterweights for the purpose of increasing pitch. The centrifugal twisting moment (CTM) generated as the propeller rotates is, however, used in combination with oil pressure to reduce propeller blade pitch. A segment of gear teeth at the butt of the blade mesh with the gears of the rotating cam to position the propeller blades in terms of pitch angle.

HAMILTON STANDARD PROPELLER CONTROL

A governor employing a flyweight assembly, speeder spring, pilot valve, oil pressure boost pump, and requisite valves is used to provide constant speed operations of the Hamilton Standard propeller. Boosted oil pressure is sent to the inboard section of the piston and ordinary engine oil pressure to the outboard surface of the piston. When the engine is on speed, the pilot valve is positioned so that oil does not enter or exit the propeller dome. To increase propeller pitch, as during an over speed condition, boosted oil pressure from the oil pump within the governor is directed to the inboard side of the piston while oil from the outboard section of the dome is allowed to drain back to the engine. This action increases propeller pitch. To reduce propeller pitch, the pilot valve moves so that oil acting on the inboard surface of the piston is allowed to drain from the dome. Engine oil pressure directed to the outboard section of the dome, along with the centrifugal twisting moment generated by the propeller blades, decrease propeller pitch.

Feathering and unfeathering the Hamilton Standard propeller are achieved through use of an auxiliary oil pump. This unit is typically driven by an electric motor and delivers oil pressure at levels greater than those generated by the oil boost pump within the governor. Electrical switches and holding coils are incorporated into the feathering and unfeathering operations. Detailed descriptions of the operation of the propeller during on speed, over speed, under speed, feathering, and unfeathering are provided below.

PRINCIPLES OF OPERATION

The pitch changing mechanism of hydromatic propellers is a hydro mechanical system in which hydraulic forces acting on the piston are transformed into mechanical rotating forces applied to the blades. Linear movement of the piston is converted to rotary

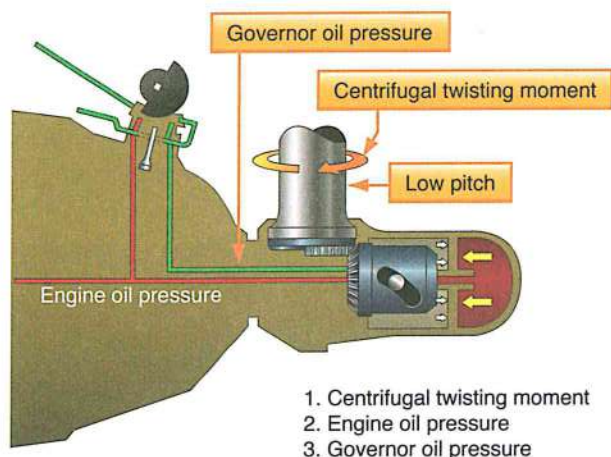

Figure 3-13. Hydromatic operational forces.

motion by a cylindrical cam with an angled slot. A bevel gear on the base of the rotating cam mates with bevel gear segments attached to the butt ends of the propeller blades, thereby controlling the pitch of the blades. This blade pitch changing action can be understood by studying the schematic in *Figure 3-13*.

The centrifugal twisting moment (CTM) acting on the blades of a spinning propeller generates a component force that tends to move the blade toward low pitch. As shown in *Figure 3-13*, a second force, engine oil pressure, is supplied to the outboard side of the propeller piston to assist in moving the blade toward low pitch.

Propeller governor oil, taken from the engine oil supply and boosted in pressure by the pump in the propeller governor, is directed against the inboard side of the propeller piston. It acts as the counterforce which can move the blades toward higher pitch. By directing this high pressure oil to, or draining it from, the inboard side of the propeller piston by means of the constant speed control unit, the force toward high pitch can balance and control the two forces toward low pitch. In this way, the propeller blade angle is regulated to maintain a selected rpm.

HYDROMATIC ON SPEED CONDITION

When the engine is operating in an on speed condition, the tension of the speeder spring acting on the pilot valve is in balance with the centrifugal force generated by the flyweight assembly. In this circumstance, the pilot valve blocks the flow of oil to and from the inboard propeller dome area. The net outcome is that the piston does not travel and the propeller pitch does not change. The output from the oil pump within the governor is bypassed through a relief valve and recirculated. (*Figure 3-14*)

HYDROMATIC UNDER SPEED CONDITION

In the under speed condition, the tension exerted by the speeder spring on the pilot valve exceeds the centrifugal action of the flyweight assembly. During the under speed condition, the pilot valve is positioned so that oil from the inboard surface of the piston is

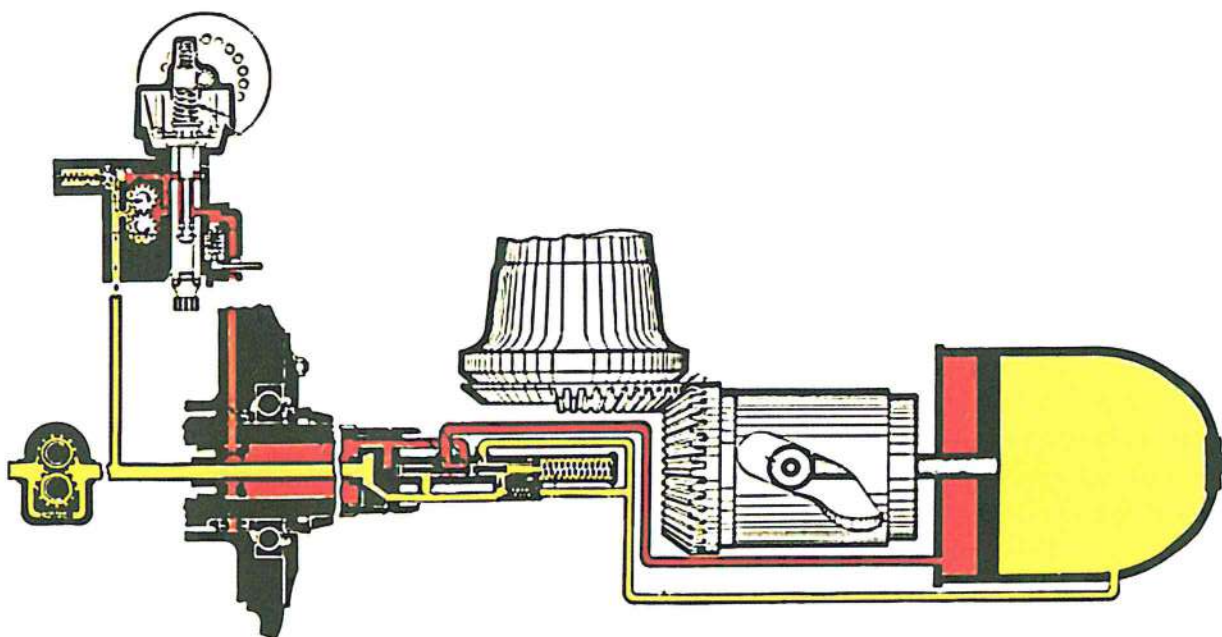

Figure 3-14. Hydromatic propeller in the on speed condition.

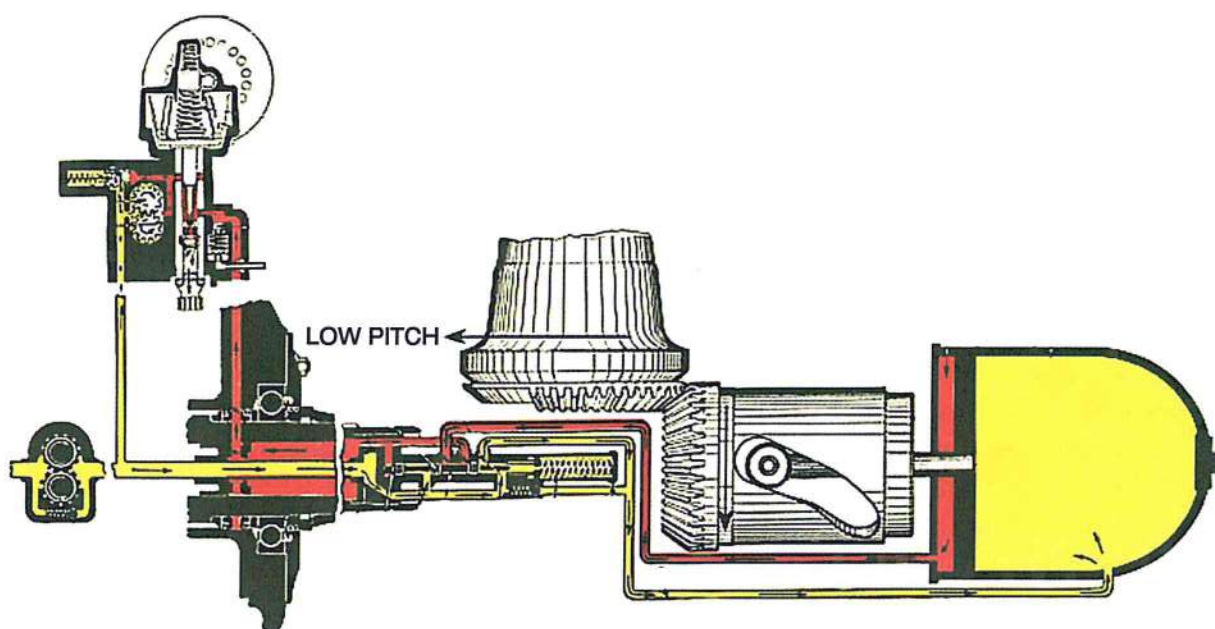

Figure 3-15. Hydromatic propeller in the under speed condition.

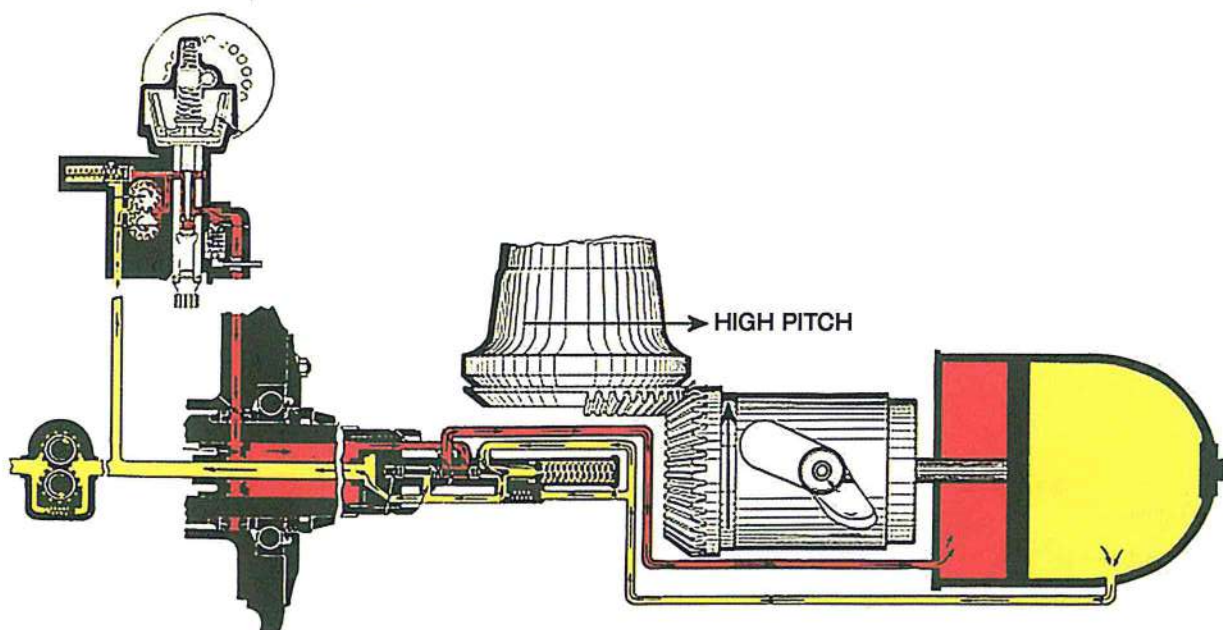

Figure 3-16. Hydromatic propeller in the over speed condition.

allowed to return to the engine. At the same time, oil under pressure from the engine fills the outboard area of the dome as the centrifugal twisting moment of the blades assists in reducing propeller pitch. The piston moves in an inboard direction. As the pitch is reduced, the engine rpm increases until the governor returns to the on speed condition. (Figure 3-15)

OVER SPEED CONDITION

During over speed conditions, the centrifugal force produced by the flyweight assembly is greater than the tension exerted by the speeder spring. When this occurs,

the pilot valve is shifted within the governor so that the output from the oil pump of the governor is directed to the inboard piston surface. Oil from the outboard area of the dome is returned to the engine. The result is that the piston moves in an outboard direction causing the propeller pitch to increase. The increase in propeller blade pitch reduces engine rpm until the governor returns to the on speed condition. (Figure 3-16)

FEATHERING OPERATION

A typical hydromatic propeller feathering installation is shown in Figure 3-17. When the feathering push

button switch is depressed, a circuit is established from the battery or DC bus through the push button holding coil and from the DC source through the solenoid relay. As long as the circuit remains closed, the holding coil keeps the push button in the depressed position. Closing the solenoid establishes the high current circuit from the DC source to the feathering motor pump unit. The feathering pump picks up oil from the engine, boosts its pressure, if necessary, to the relief valve setting of the governor pump, and supplies it to the governor high pressure transfer valve connection. Auxiliary oil entering the high pressure transfer valve connection shifts the governor transfer valve, which hydraulically disconnects the governor from the propeller and at the same time opens the propeller governor oil line to auxiliary oil from the feathering pump. The oil flows through the engine transfer rings, through the propeller shaft governor oil passage, through the distributor valve port, between lands, and finally to the inboard piston end or the piston by way of the valve inboard outlet.

The distributor valve does not shift during the feathering operation. It merely provides an oil passageway to the inboard piston end for the high pressure auxiliary oil flow and the escape route for outboard piston oil. The distributor valve spring

is backed up by engine oil pressure, which means that at all times the pressure differential required to move the piston is identical with that applied to the distributor valve. The feathering operation may be accomplished while the engine is running or it may be performed when the engine is not running as the auxiliary pump, not the governor, provides the necessary hydraulic action.

The propeller piston moves outboard under the auxiliary oil pressure from the feathering pump at a speed proportional to the rate the oil is supplied to the dome. This piston motion is transmitted through the piston rollers operating in the oppositely inclined cam tracks of the fixed cam and the rotating cam, and is converted by the bevel gears into the blade twisting moment. Only during feathering or unfeathering is the low mechanical advantage portion of the cam tracks used. (The low mechanical advantage portion lies between the break and the outboard end of the track profile.) Oil at engine pressure, displaced from the outboard piston end, flows through the distributor valve outboard inlet, past the outboard end of the valve land, through the valve port, into the propeller shaft engine oil passage, and is finally delivered into the engine lubricating system. Thus, the blades move toward the full high pitch, or feathered, position.

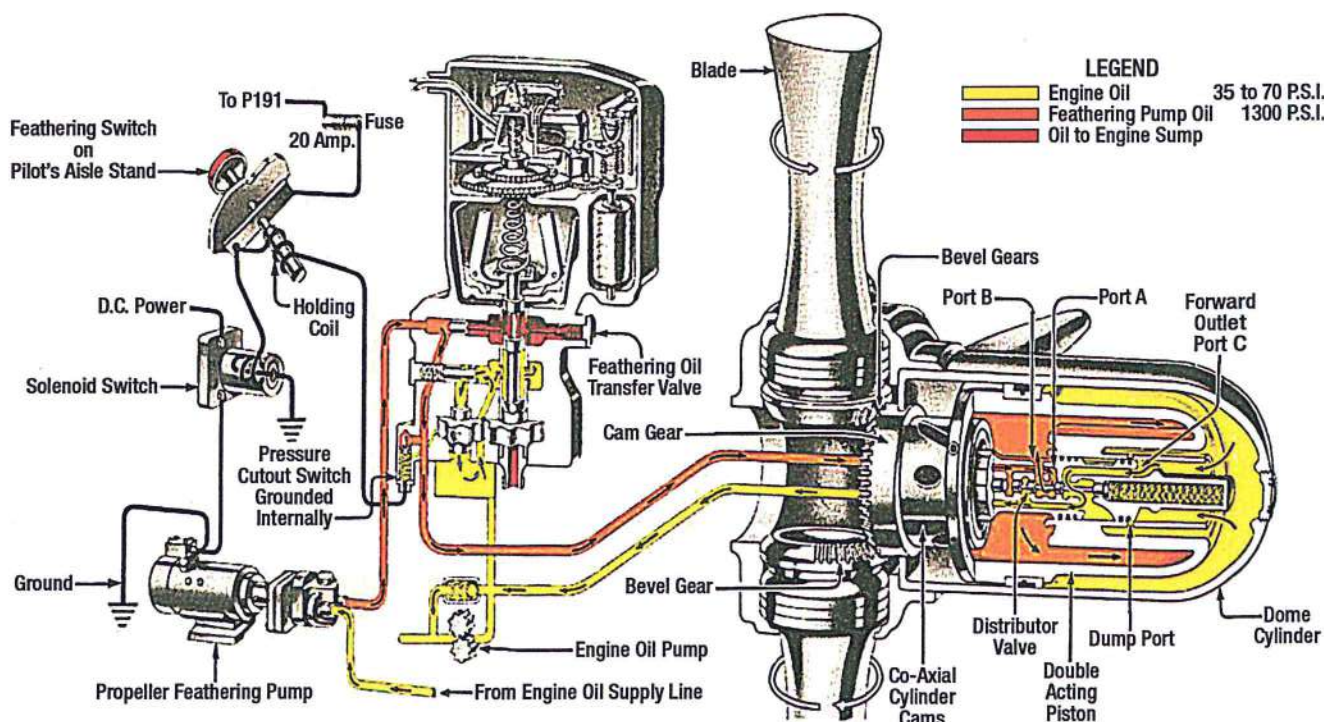

Figure 3-17. Hydromatic propeller feathering.

Having reached the full feathered angle, further movement of the mechanism is prevented by physical contact between the high angle stop ring in the base of the fixed cam and the stop lugs set in the teeth of the rotating cam. The oil pressure in the inboard piston end now increases rapidly, and upon reaching a set pressure, the electric cutout switch automatically opens. This cutout pressure is less than that required to shift the operation of the distributor valve needed to unfeather the propeller.

Opening the switch de-energizes the holding coil and releases the feathering push button control switch. Release of this switch breaks the solenoid relay circuit, which shuts off the feathering pump motor. The pressures in both the inboard and outboard ends of the piston drop to zero, and, since all the forces are balanced, the propeller blades remain in the feathered position. Meanwhile, the governor high pressure transfer valve has shifted to its normal position as soon as the pressure in the propeller governor line drops below that required to push and hold the valve open.

UNFEATHERING OPERATION

To unfeather a hydromatic propeller, depress and hold in the feathering switch push button control switch. As in the case of feathering the hydromatic propeller, the control circuits from the battery or DC source through the holding coil and from the DC source through the solenoid are completed when the solenoid closes. The high current circuit from the battery starts the motor pump unit, and oil is supplied at a high pressure to the governor transfer valve. The operator must continue to physically depress the switch until the propeller comes out of feather and the engine rotates to a specific rpm (e.g., 800 to 1 000 rpm). When the specified windmilling rpm is established, the feathering switch button is released and the engine is restarted to establish normal engine operation.

While the feathering button is depressed, auxiliary oil entering through the high pressure transfer valve connection shifts the governor transfer valve and disconnects the governor from the propeller line; in the same operation, auxiliary oil is directed to the propeller. The oil flows through the engine oil transfer rings, through the propeller shaft governor oil passage, and into the distributor valve assembly.

When the unfeathering operation begins, the piston is in the extreme outboard position. The oil enters the inboard piston area of the cylinder by way of the distributor valve inboard outlet. As the pressure on the inboard end of the piston increases, the pressure against the distributor valve land also builds up. When the pressure becomes greater than the combined opposing force of the distributor valve spring and the oil pressure behind this spring, the distributor valve shifts. Once the valve shifts, the passages through the distributor valve assembly to and from the propeller are reversed. A passage is opened between lands and through a port to the outboard piston end by way of the distributor valve outlet. As the piston moves inboard under the auxiliary pump oil pressure, oil is displaced from the inboard piston end through the inlet ports between the valve lands, into the propeller shaft engine oil lands, and into the propeller shaft engine oil passage where it is discharged into the engine lubricating system. At the same time, the pressure at the cutout switch increases and the switch opens. However, the circuit to the feathering pump and motor unit remains complete as long as the feathering switch is depressed by the operator.

With the inboard end of the propeller piston connected to drain oil and auxiliary oil pressure from the feathering pump flowing to the outboard end of the piston, the piston moves inboard, unfeathering the blades. As the blades are unfeathered, they begin to windmill and assist the unfeathering operation by the added force toward low pitch brought about by the centrifugal twisting moment. When the engine speed has increased to approximately 1 000 rpm, the operator shuts off the feathering pump motor by releasing the switch. The pressure in the distributor valve and at the governor transfer valve decreases, allowing the distributor valve to shift under the action of the governor high pressure transfer valve spring. This action reconnects the governor with the propeller and establishes the same oil passages through the distributor valve that are used during constant-speed and feathering operations. The pilot will have to follow the restart and engine warm up procedures following the unfeathering operation before bringing the engine up to speed and synchronizing the engine rpm with the other engines on the aircraft.

TURBOPROP ENGINES AND PROPELLER CONTROL SYSTEMS

Turboprop engines are used with many single, twin, and commuter aircraft. (Figure 3-18) Smaller turboprop engines, such as the Pratt and Whitney PT-6, are normally installed on single and twin engine designs; the power ranges from 500 to 2 000 shaft horsepower. (Figure 3-19) Commuter aircraft use turboprop engines, such as the Pratt and Whitney 150 and AE2100 that can deliver up to 5 000 shaft horsepower to power mid sized to large turboprop aircraft. (Figure 3-20) The turboprop propeller is operated by a gas turbine engine through a reduction gear assembly. It has proven to be an extremely efficient power source. The combination of propeller, reduction gear assembly, and turbine engine is referred to as a turboprop powerplant.



Figure 3-18. Turboprop Aircraft.

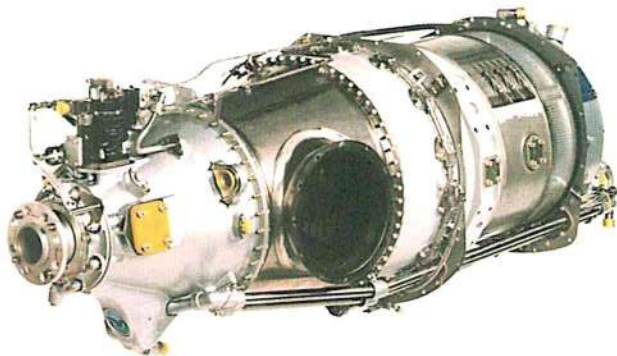

Figure 3-19. PT-6 Turboprop engine.

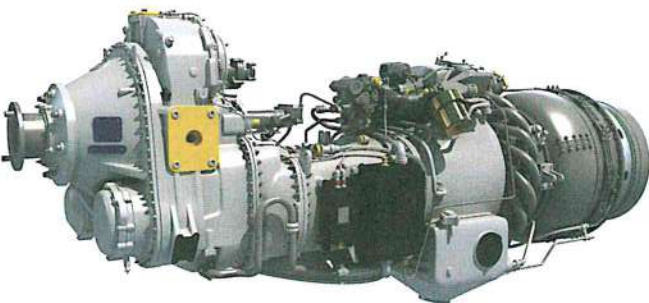

Figure 3-20. Large turboprop engine.

Turbojet and turbofan engines produce thrust directly; the turboprop engine produces thrust indirectly because the compressor and turbine assembly furnishes torque to a propeller, producing the major portion of the propulsive force that drives the aircraft. The turboprop fuel control and the propeller governor are connected and operate in coordination with each other.

The power lever directs a signal from the cockpit to the fuel control for a specific amount of power from the engine. The fuel control and the propeller governor together establish the correct combination of rpm, fuel flow, and propeller blade angle to create sufficient propeller thrust to provide the desired power. Simultaneously managing these parameters becomes a complicated process.

The propeller control system is divided into two types of control: one for flight and one for ground operation. For flight, the propeller blade angle and fuel flow for any given power lever setting are governed automatically according to a predetermined schedule. Below the “flight idle” power lever position, the coordinated rpm blade angle schedule becomes incapable of handling the engine efficiently. Here, the ground handling range, referred to as the beta range, is encountered. In the beta range of the throttle quadrant, the propeller blade angle is not governed by the propeller governor, but is controlled by the power lever position. When the power lever is moved below the start position, the propeller pitch becomes negative to provide reverse thrust for rapid deceleration of the aircraft after landing. Reverse thrust may also be used to back the airplane up while on the ground. On seaplanes, reverse thrust provides an additional dimension of maneuverability while controlling the aircraft when it is on the water.

A characteristic of the turboprop is that changes in power are not related to engine speed, but to turbine inlet temperature. During flight, the propeller maintains a constant engine speed. This speed is known as the 100 percent rated speed of the engine, and it is the design speed at which most power and best overall efficiency can be obtained. Power changes are effected by changing the fuel flow. An increase in fuel flow causes an increase in turbine inlet temperature and a corresponding increase in energy available at the turbine. The turbine absorbs more energy and transmits it to the propeller in the form of torque. The propeller,

in order to absorb the increased torque, increases blade angle, thus maintaining constant engine rpm with added thrust.

REDUCTION GEAR ASSEMBLY

The function of the reduction gear assembly is to reduce the high rpm from the spinning turbine to a propeller rpm that can be maintained without exceeding the maximum propeller tip speed (normally around the speed of sound). Most reduction gear assemblies use a planetary gear reduction system. (Figure 3-21) Mounting pads are available for propeller governor(s), oil pump, and other accessories. A propeller brake is often incorporated into the gearbox. The propeller brake is designed to prevent the propeller from windmilling when it is feathered in flight, and to decrease the time for the propeller to come to a complete stop after engine shutdown.

TURBO-PROPELLER ASSEMBLY

The turbo-propeller provides an efficient and flexible means of using the power of the engine at any condition in flight (alpha range). (Figure 3-22) For

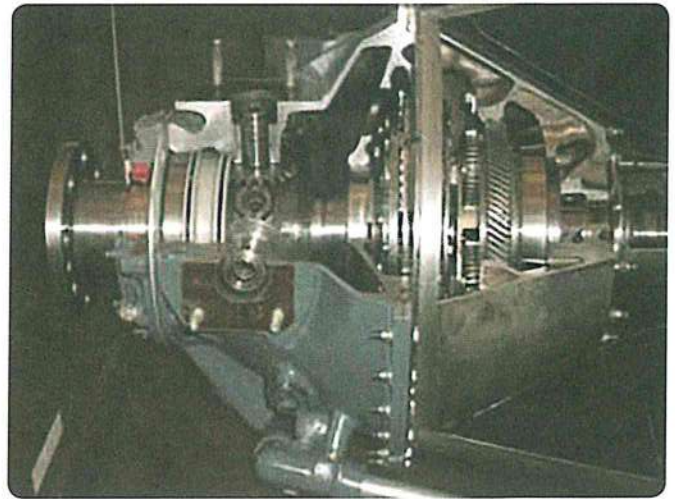

Figure 3-21. Turboprop gear reduction box.

ground handling and reversing (beta range), the propeller can be operated to provide either zero or negative thrust. Low thrust may also be available in beta. The major subassemblies of the propeller and associated control network are the cylinder and piston assembly composing the dome, hub, pitch change mechanism, low pitch stop assembly, over

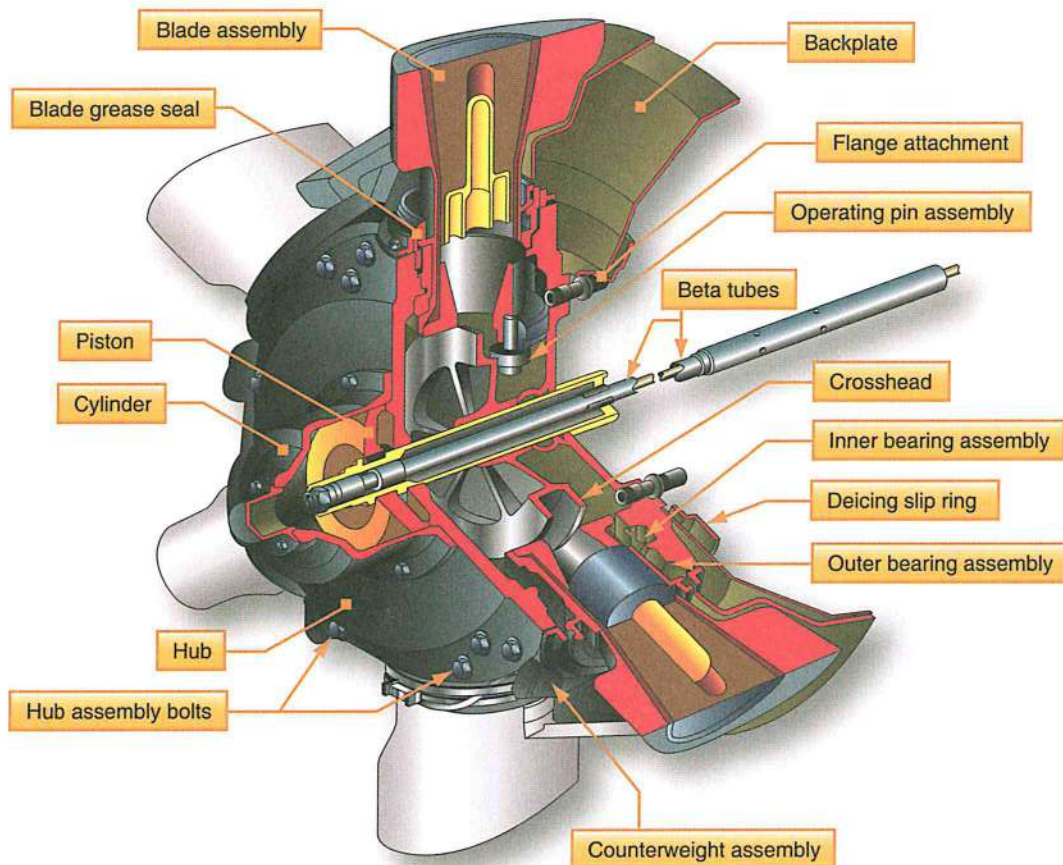

Figure 3-22. Cutaway turboprop propeller.

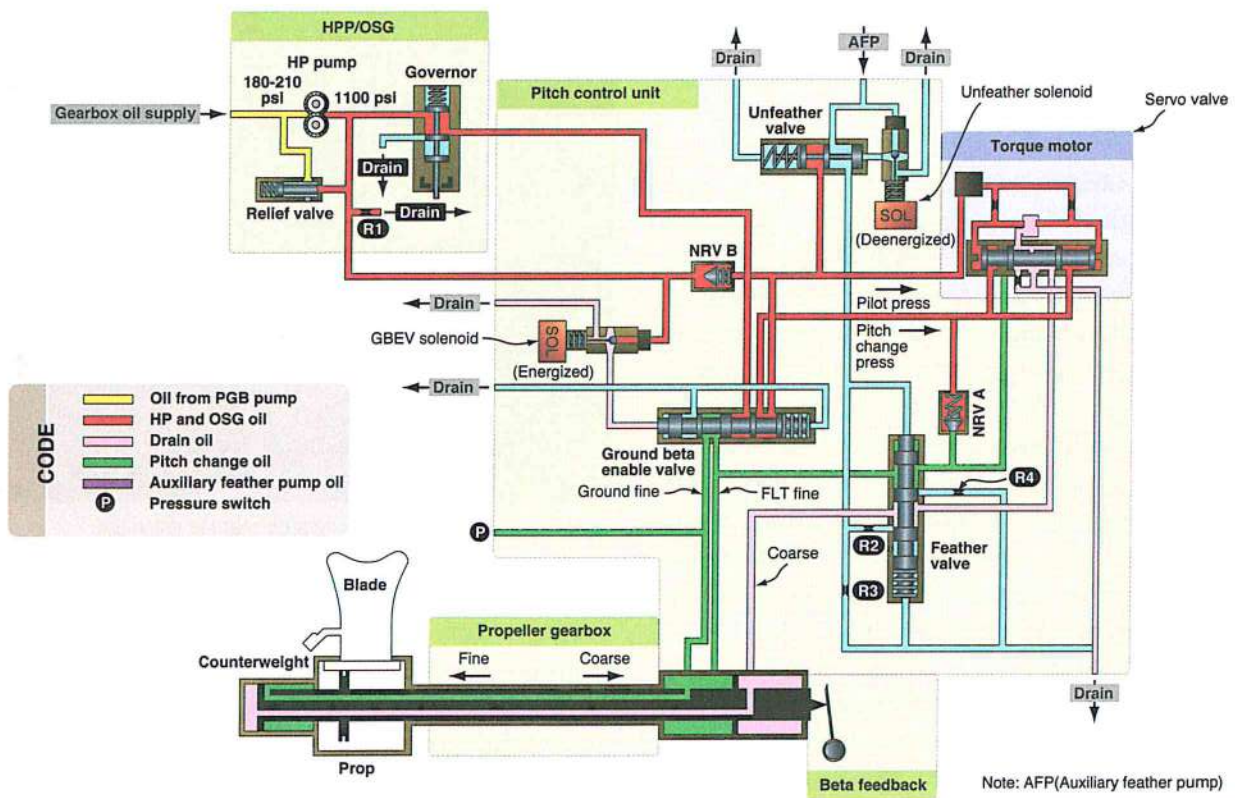

Figure 3-23. Propeller control system schematic.

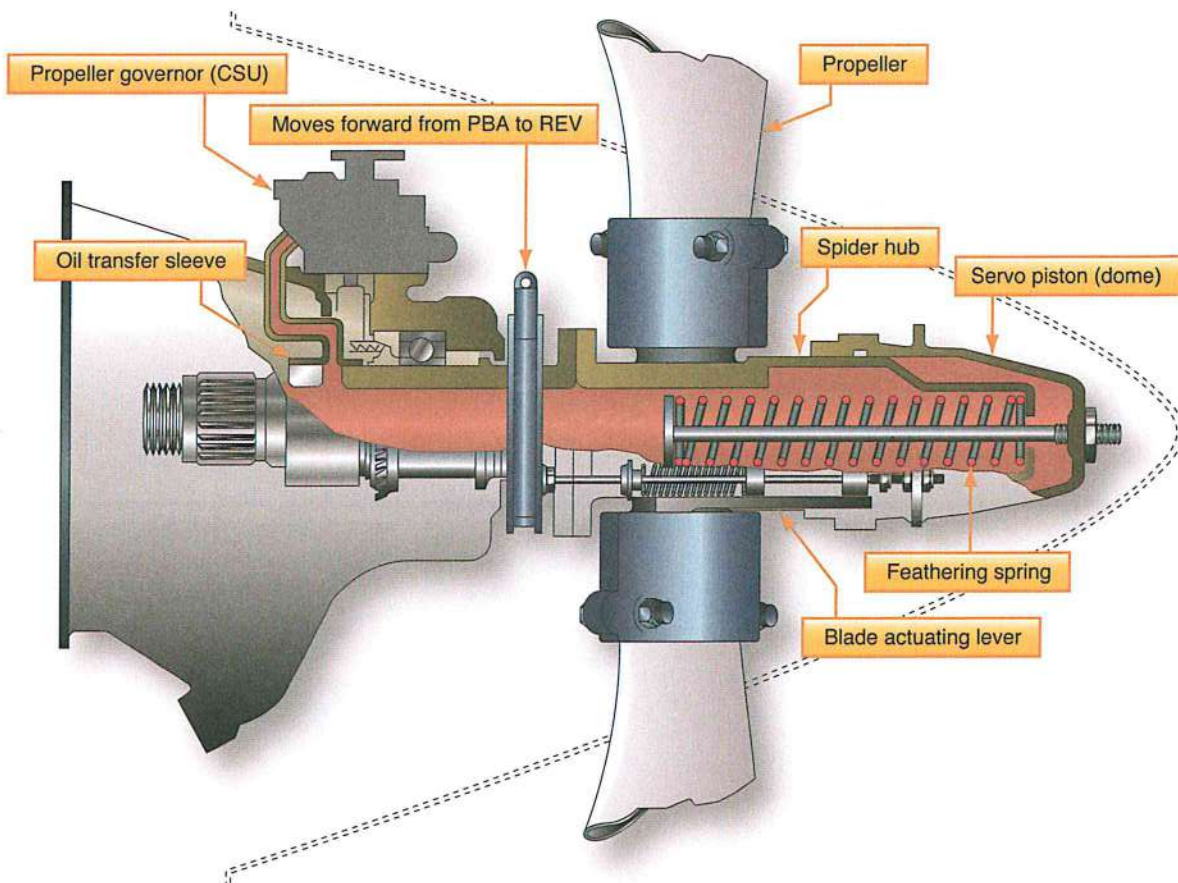

Figure 3-24. PT-6 Propeller pitch change cutaway.

speed governor, pitch control unit, auxiliary pump, feather and unfeather valves, torque motor, spinner, de-ice timer, beta feedback assembly, and propeller electronic control. Modern turboprop engines use dual Full Authority Digital Engine Control (FADEC) to control both engine and propeller. The spinner assembly is a cone shaped configuration that mounts on the propeller and encloses the dome and barrel to reduce drag.

The synchrophasing system is designed to maintain a preset angular relationship between the designated master propeller and the slave propeller(s). Propeller operation is controlled by a mechanical linkage from the cockpit mounted power lever and the emergency engine shutdown handle (if the aircraft is provided with one) to the coordinator, which in turn is linked to the propeller control input lever. Newer designs use electronic throttle control that is linked to the FADEC controller.

Turbo propeller control assemblies have feathering systems that feather the propeller when the engine is shut down in flight. The propeller can also be unfeathered during flight, if the engine needs to be started again. Propeller control systems for large turboprop engines differ from smaller engines because they are dual acting, which means that hydraulic pressure is used to increase and decrease propeller blade angle. (Figure 3-23)

PRATT AND WHITNEY PT-6 HARTZELL PROPELLER SYSTEM

The PT-6 Hartzell propeller system is a popular design used on a number of aircraft that incorporates three, four, or six bladed propellers made of aluminum or composite materials. It is a constant-speed, feathering, reversing propeller system using a single acting governor. Oil from the propeller governor feeds into the propeller shaft and to the servo piston by way of the oil transfer sleeve mounted on the propeller shaft. (Figure 3-24) As oil pressure increases, the

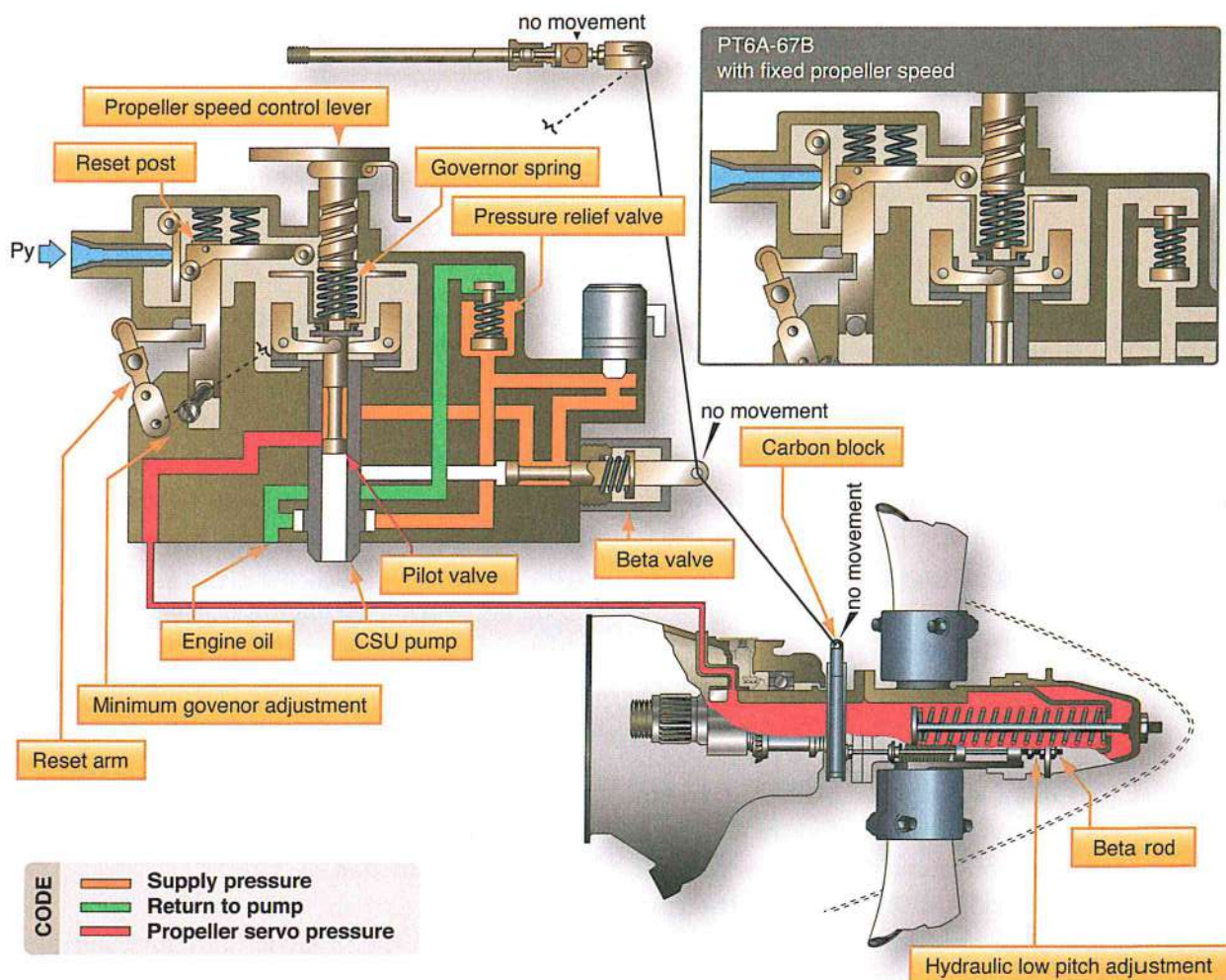

Figure 3-25. PT-6 Governing schematic.

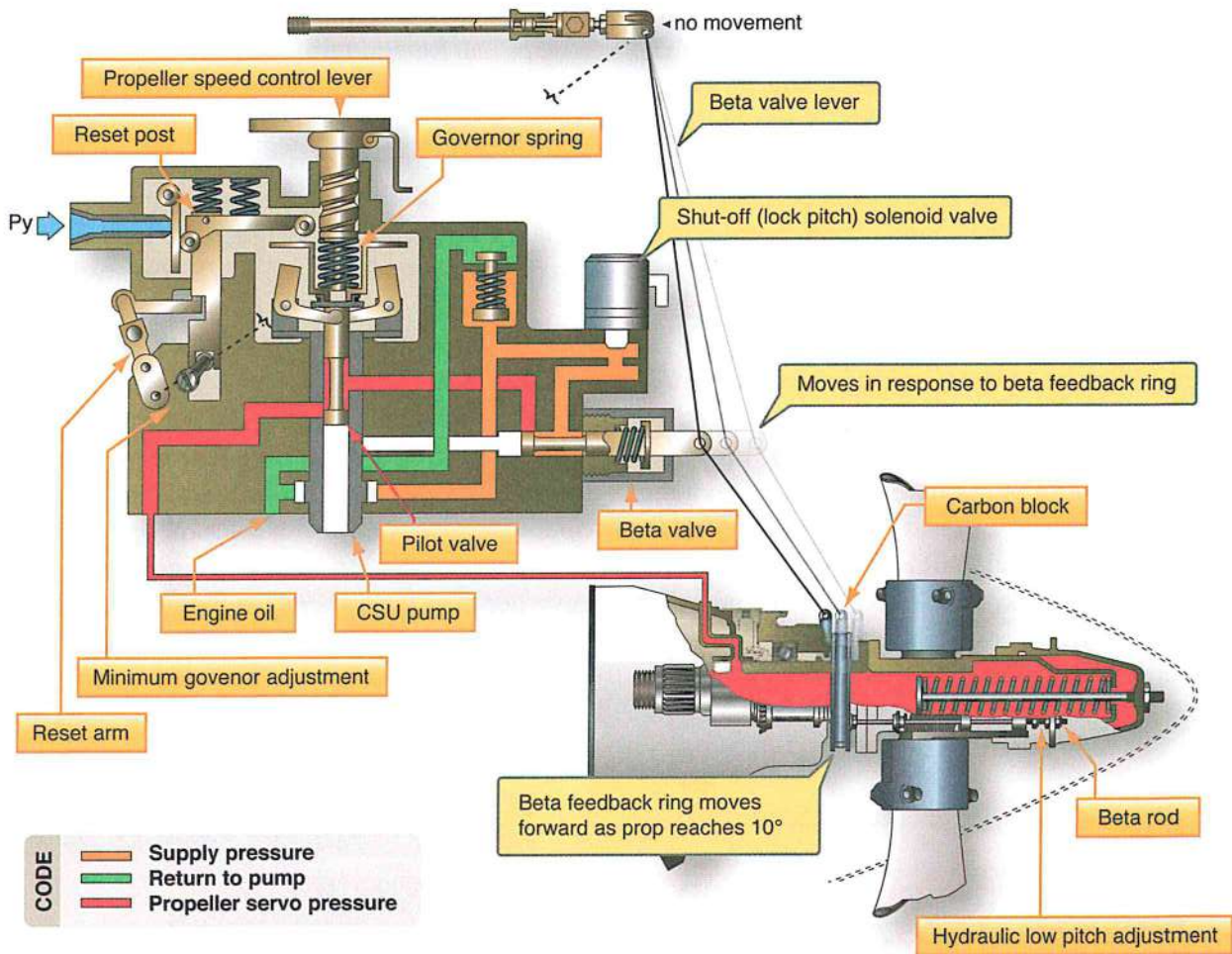

Figure 3-26. PT-6 Beta mode forward operation.

servo piston is pushed forward, or outboard, and the feather spring is compressed. Servo piston movement is transmitted to the propeller blade collars using a system of link bars. When oil pressure acting on the piston is decreased, the feathering spring and propeller blade counterweights force the oil out of the servo piston and change the blade pitch to a high pitch position. An increase in oil pressure drives the blades towards low pitch.

Engine oil is supplied to the governor from the engine oil supply. A gear pump, mounted at the base of the governor, increases the flow of oil going to the constant speed unit (CSU) relief valve. When the oil pressure reaches the desired level, the relief valve opens to maintain the governor oil pressure. The governor oil pressure is approximately 400 psi. When the rpm selected by the pilot is reached, the flyweight force is in balance with the spring tension of the speeder spring. The governor flyweights are then on speed. When the

engine output power is increased, the power turbines tend to increase speed. The flyweights in the CSU sense this acceleration and the flyweights go into an over speed condition because of the increase centrifugal force. This force causes the control valve to move up and restrict oil flow into the propeller dome. (Figure 3-25) The feathering spring increases the propeller pitch to maintain the selected speed as the volume of oil in the dome is reduced. Reducing engine power causes an under speed of the flyweights, downward movement of the control valve, and more oil in propeller dome, resulting in a lower pitch to control propeller speed. The propeller governor houses an electro magnetic coil, which is used to match the rpm of multiple propellers during cruise. An aircraft supplied synchrophaser unit controls this function.

At low power, the propeller and governor flyweights do not turn fast enough to compress the speeder spring. (Figure 3-26) In this condition, the control

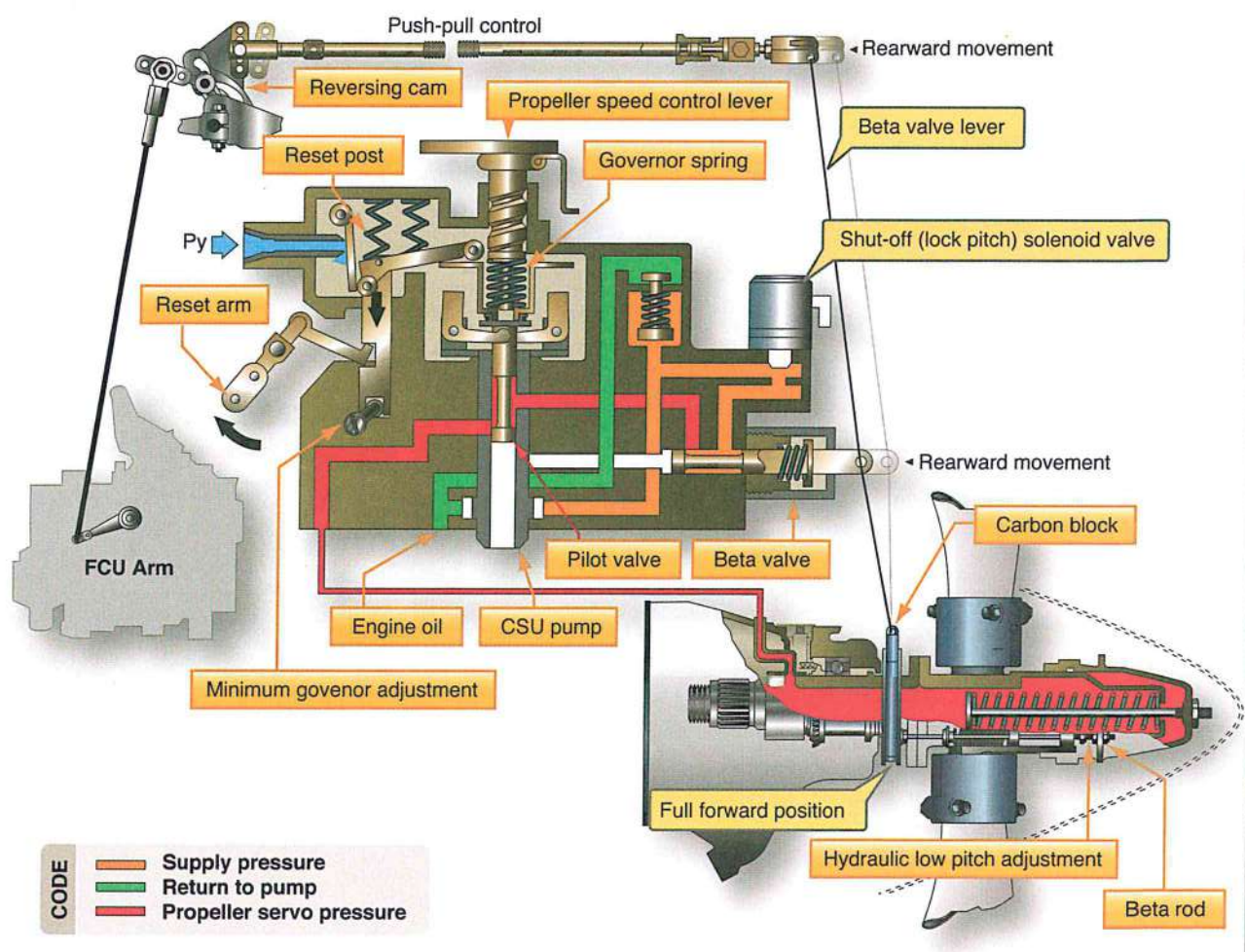

Figure 3-27. PT-6 Beta mode reverse operation.

valve moves down and high pressure oil pushes the dome forward moving the propeller blades towards low pitch. Any further movement pulls the beta rod and slip ring assembly forward. The forward motion of the slip ring is transmitted to the beta valve via the beta lever and the carbon block. The link bar connecting the beta valve and carbon block assembly hinges at the stationary beta cable during this operation. Forward movement of the beta valve stops the oil supply to the propeller. This prevents the blade angles from going any lower. This is the primary blade angle (PBA) and is the minimum blade angle allowed for flight operation. If the engine power is reduced when the propeller is at the primary blade angle, the propeller speed decreases since the blade angle does not change.

The lock pitch solenoid valve prevents the propeller from going into reverse or below the primary blade angle in the event of a beta system malfunction in flight. The solenoid is energized by a switch (airframe supplied)

mechanically connected to the propeller slip ring linkage via a second carbon block. As oil pressure leaks off around the propeller shaft oil transfer sleeve, the blade angle slowly drifts back toward high pitch. This deactivates the low pitch solenoid valve and restores the oil supply to the propeller servo. The low pitch solenoid valve cycles (close/open) as backup to the beta valve function. Moving the power lever backwards causes the reversing cam and cable to move the beta valve backward, allowing more oil to flow into the propeller dome, and causing the blades to go towards reverse pitch. (Figure 3-27) In this instance, the beta link connected to the cable, beta valve, and carbon brush assembly hinges at the carbon brush thereby pushing the beta valve into the reduction gearbox case.

As the blades move to reverse, the dome pulls the slip ring forward and moves the beta valve outward, restricting the oil flow. In this instance the beta link hinges at the beta cable. This stops the blade movement

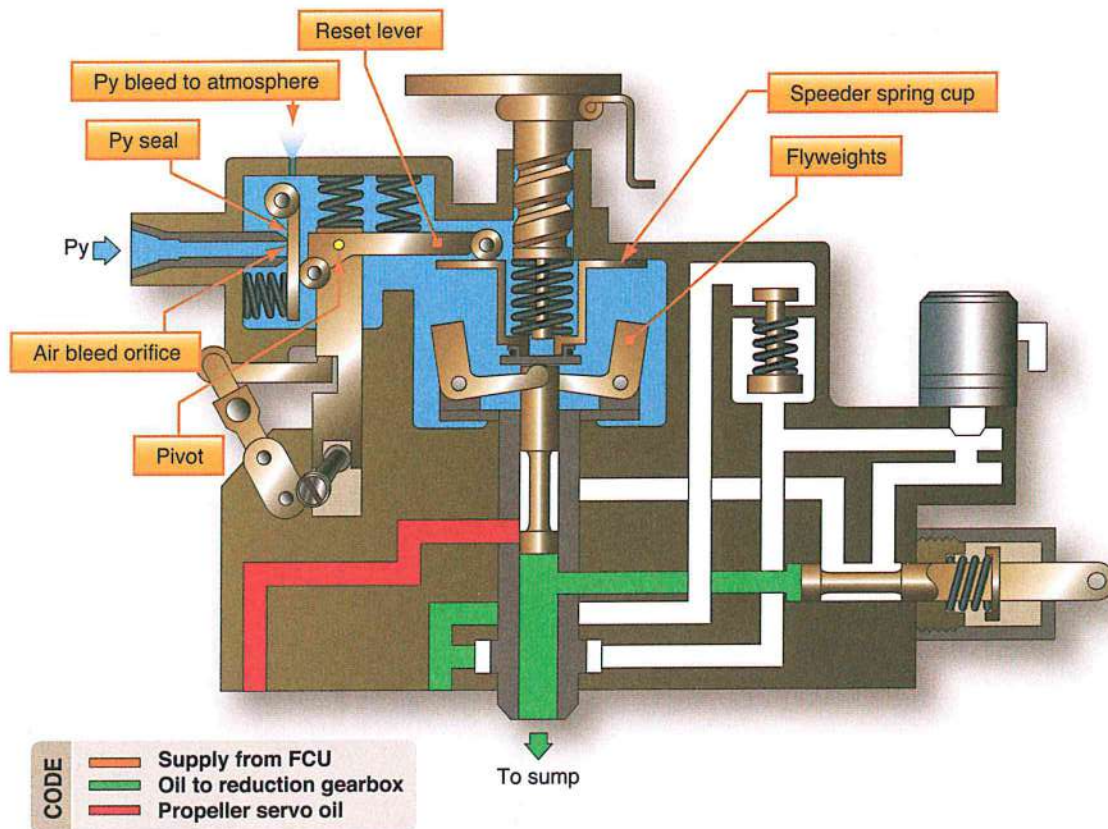

Figure 3-28: Nf (Engine over speed) governor.

toward reverse. To obtain more reverse thrust, move the power lever back more to reset the beta valve inward, and repeat the process. Move the reset arm on the CSU rearward by the interconnecting rod at the same time the blade angle moves toward reverse. This causes the reset lever and reset post to move down in the CSU, bringing the reset lever closer to the speeder spring cup. As propeller speed increases due to the increase in engine power, the governor flyweights begin to move outwards. Since the reset lever is closer to the speeder spring cup, the cup contacts the reset lever before the flyweights would normally reach the on speed position (95 percent propeller speed instead of 100 percent). As the reset lever is pushed up by the flyweights/speeder spring cup, the PY (pressurized air line) air bleed mechanism from the fuel control unit (FCU) is unseated and allows the PY pressure to bleed down which lowers the fuel flow to the engine and reduces engine power, and thus propeller speed. In reverse, propeller speed remains 5 percent below the selected propeller speed so that the control valve remains fully open, and only the beta valve controls the oil flow to the propeller dome.

In this mode, the propeller speed is no longer controlled by changing the blade angle. It is now controlled by limiting engine power. Bringing the propeller lever to the feather position causes the speed selection lever on the CSU to push the feathering valve plunger and allows propeller servo oil to dump into the reduction gearbox sump. The pressure loss in the propeller hub causes the feathering spring and the propeller blade counterweights to feather the propeller. In the event of a propeller over speed not controlled by the propeller over speed governor (oil governor), the flyweights in the propeller governor move outward until the speeder spring cup contacts the reset lever. (Figure 3-28) The movement of the reset lever around its pivot point opens the PY air passage. PY bleeds into the reduction gearbox which causes the fuel control unit to reduce fuel flow to the engine. This prevents the propeller/power turbines from accelerating beyond 106 percent rpm.

OVER SPEED PROTECTION

The oil over speed governor houses a set of flyweights connected to a control valve that is driven by a beveled gear mounted on the propeller shaft. (Figure 3-29)

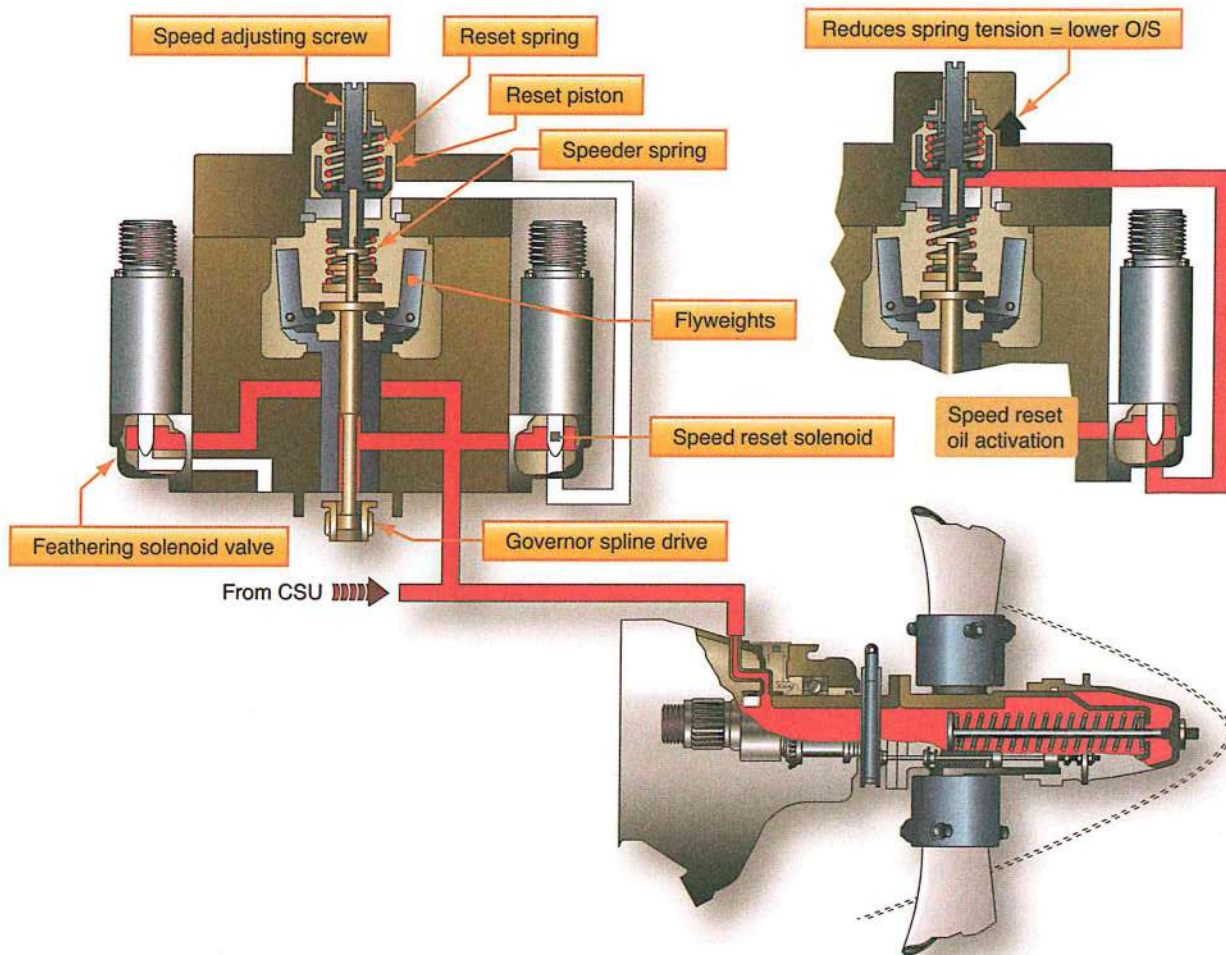

Figure 3-29. Over speed governor.

The flyweight's centrifugal force is acting against two springs: a speeder spring and a reset spring. When the propeller speed reaches a specified limit (four percent over maximum propeller speed), the governor flyweights lift the control valve and bleed off propeller servo oil into the reduction gearbox sump, causing the blade angle to increase. An increase in blade pitch puts more load on the engine and slows down the propeller. To test the unit, the speed reset solenoid is activated and servo oil pressure pushes against the reset piston to cancel the effect of the reset spring. With less spring tension acting on the flyweights, the over speed governor can be tested at speeds lower than maximum.

On twin installations, a second solenoid valve is mounted on the over speed governor and is used in conjunction with the aircraft autofeather system. The system is switched on, or armed, for takeoff and, in the event of an engine malfunction, energizes the solenoid

valve to dump propeller servo oil into the reduction gearbox sump. The feathering spring and propeller blade counterweights move the propeller quickly to feather.

ELECTRICALLY CONTROLLED PROPELLERS

Where most controllable pitch propellers utilize hydraulically operated governors and pitch change mechanisms, some propellers use electrical motors to control propeller blade pitch. Aside from the Beechcraft electric propellers mentioned in the unit introducing controllable-pitch propellers, Curtiss-Wright electric propellers were prominent during their day. A number of airplanes were equipped with electrically controlled propellers during and following World War II.

Electrically controlled propellers share many features with the hydraulically controlled models, such as constant speed operation, feathering and unfeathering,

and reversing. They also include capabilities not incorporated in the hydraulically controlled systems.

Components composing the electrically controlled propellers include the motor, a motor brake, a gearbox, the propeller hub and blades, slip rings and brushes, governor, and related switches and controls. The motor is operated using direct current (DC) power and is reversible. A special voltage booster is used to allow higher voltage to reach the motor. The voltage booster increases the speed at which the propeller blades change angle. This feature is especially useful during feathering and going into reverse operations where quick action is preferred. The motor brake is in the locked position until the motor is energized. The motor brake is spring loaded in the brake mode. It uses a solenoid operated release mechanism to remove the brake action to allow the motor to position the propeller blades at the desired angle.

Within the gearbox is a two stage, planetary gear reduction system. The high rotational speed of the motor is reduced to a high torque, slow revolving output. Not only does the gear reduction provide the necessary torque needed to change propeller pitch, but the slow rotational speed reduces the likelihood of overshooting the intended blade angle. Beveled gears are used to connect the output of the gearbox to the blade roots. The hubs are formed from steel and retain the blades using bearings. A special lubricant is used within the hub. As the hub assembly does not receive warm oil from the engine as hydraulically operated propellers, the lubricant must be able to operate in extreme cold conditions.

Propeller blades for Curtiss-Wright electric models may either be hollow steel blades or forged aluminum. Curtiss-Wright electric propellers are frequently equipped with blade cuffs that cover the blade shanks and offer more cooling airflow to the engine through the opening in the nacelle.

The brushes and slip rings carry electricity to the motor, brake assembly, and limit switches. A governor is geared to the engine and provides constant speed operations, when selected. Switches are used by the pilot to establish the desired mode of operation. The propeller may be operated manually with controls to increase or decrease propeller pitch or the propeller may be operated as a

constant-speed unit with the ability to synchronize engine rpm of multi engine aircraft. Limit switches are included to control pitch travel. A feathering switch provides that function in a quick and simple fashion. (Figure 3-30)

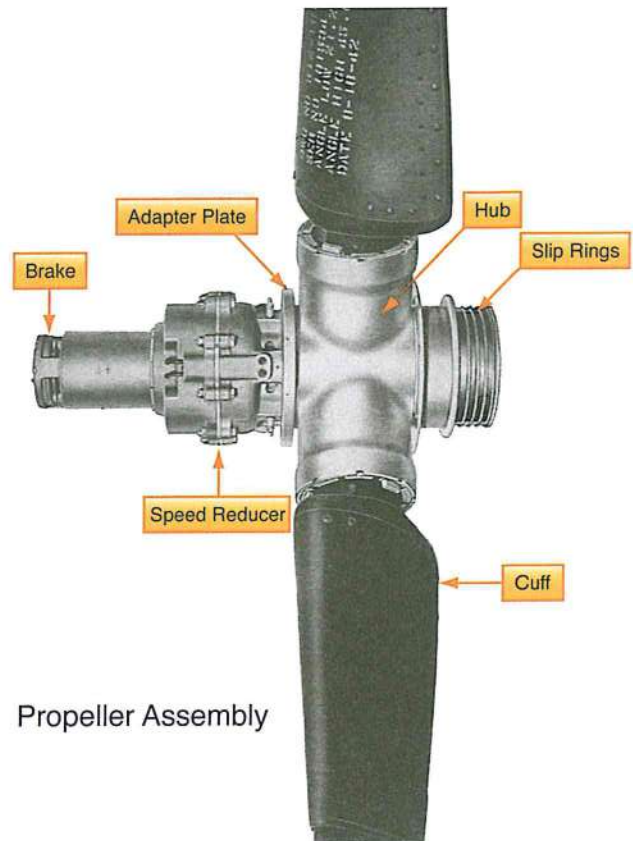

Propeller Assembly

Figure 3-30. Curtiss-Wright electrically controlled propeller.

The pilot controls the propeller using a switch in combination with a propeller control lever. The main switch has four positions, off, increase rpm, decrease rpm, and automatic. The off position de-energizes the system. The propeller remains in its current pitch position unless the feather switch or reverse pitch switch are activated. The increase rpm and decrease rpm positions are spring loaded and make contact as long as the pilot holds the switch in the desired mode. The pilot must hold the switch in the increase or decrease rpm position to activate the system. Once the switch is released, it returns to the off position and the propeller is locked into a new pitch angle. In such operations, the propeller acts like a fixed pitch propeller that has the ability to vary pitch settings. As an example, after setting the pitch for cruise operation, if the pilot raises or lowers the nose, the engine will lose or gain rpm unlike a constant-speed operation that will keep the engine at

the same rpm. In the event of an electrical failure, the propeller pitch will remain in the position it was in when the power failure occurred. This feature is due to the spring loaded motor brake.

When the control switch is placed in the automatic position, an engine driven propeller governor is incorporated. The governor uses switches to increase and decrease pitch to maintain constant engine rpm. As the automatic position is a continuous mode of operation, the pilot does not need to hold the switch in this position once selected. Similar to a hydraulically operated governor, the units associated with the electric propellers use a flyweight and speeder spring arrangement. When the governor is on speed, flyweight action and speeder spring are in balance and no electrical signal is sent to the brake and motor. When the governor is in an under speed condition, the governor activates the pitch change motor to reduce propeller pitch until the governor returns to the on speed condition. Similarly, if the governor is in the over speed condition, the governor sends a signal to the pitch change motor to increase rpm until the engine returns to the on speed rpm. The governor control lever is normally located adjacent to the throttle in a fashion similar to hydraulically operated governors. Full forward on the governor control lever provides low pitch. As the control is moved aft, the propeller will increase pitch to maintain a lower on speed rpm. Multi engine aircraft equipped with electric propellers may have provisions for synchronizing the engine rpms.

To feather the propeller, the feathering switch is moved from the normal position to the feather position. The single step procedure disconnects the normal operation mode and engages the feathering circuit. The propeller will feather regardless of the positions of the other switches or control levers. If the system includes a voltage booster, an electric motor will drive a dedicated generator that provides a higher voltage to the system. This action provides a quicker feathering operation. The voltage booster cuts out when the propeller reaches the feathered position. To unfeather the propeller, return the feather switch to the normal position and hold the selector switch to the Increase rpm position until the engine rotates at the appropriate rpm required for starting and engine warm up. There is no limit to the number of times the propeller may be feathered and unfeathered during flight. A physical guard, or cover, to prevent inadvertent feathering operations, protects the feathering switch.

Reverse pitch operations are conducted with a separate, dedicated switch. The operation is similar to feathering in that the normal circuits are disconnected and the reverse circuit activated. Correspondingly, if the system is equipped with a voltage booster, the assembly will increase voltage applied to the motor to expedite the reversing operation. As with feathering operations, the voltage booster will become disengaged when the reverse pitch position is attained.

Question: 3-1

What data does an propeller governor receive in order to adjust oil pressure to the propeller hydraulic cylinder?

Question: 3-5

Describe what is meant by an underspeed condition.

Question: 3-2

Name four factors that separately or together work to move a propeller to high pitch.

Question: 3-6

If governor supplied oil is lost during operation of a constant speed feathering propeller, to what position will the blades move?

Question: 3-3

Name two factors that separately or together work to move a propeller to low pitch.

Question: 3-7

A reciprocating engine propeller governor system depends on engine rpm to establish the proper pitch angle. On what factor does on turboprop engine governor system depend?

Question: 3-4

When a pilot makes adjustments to the propeller control knob in the cockpit, what exactly is he/she adjusting?

Question: 3-8

Of all the forces which simultaneously act to adjust the pitch of a propeller blade, which is the greatest?

ANSWERS

Answer: 3-1

Engine rpm

Answer: 3-5

The engine is operating at an rpm below that selected by the pilot.

Answer: 3-2

Blade counter weights; springs; pneumatic pressure against the piston; aerodynamic twisting motion.

Answer: 3-6

The blades will increase pitch until the feather position.

Answer: 3-3

Governor oil pressure to the propeller piston; centrifugal twisting moment.

Answer: 3-7

Turbine inlet temperature.

Answer: 3-4

Tension on the speeder spring which opposes the movement of the flyweights.

Answer: 3-8

Oil pressure from the governor.



PROPELLER

PROPELLER SYNCHRONIZING

SUB-MODULE 04

PART-66 SYLLABUS LEVELS

CERTIFICATION CATEGORY →

| A | B1 |
|---|----|
| - | 2 |

Sub-Module 04
PROPELLER SYNCHRONIZING
 Knowledge Requirements

17.4 - Propeller Synchronizing

Synchronizing and synchrophazing equipment.

Level 2

A general knowledge of the theoretical and practical aspects of the subject and an ability to apply that knowledge.

Objectives:

- (a) The applicant should be able to understand the theoretical fundamentals of the subject.
- (b) The applicant should be able to give a general description of the subject using, as appropriate, typical examples.
- (c) The applicant should be able to use mathematical formula in conjunction with physical laws describing the subject.
- (d) The applicant should be able to read and understand sketches, drawings and schematics describing the subject.
- (e) The applicant should be able to apply his knowledge in a practical manner using detailed procedures.

PROPELLER SYNCHRONIZING

PROPELLER SYNCHRONIZATION SYSTEMS

Where most multi engine aircraft have a number of advantages in terms of operation when compared to single engine aircraft (e.g., large useful loads, long flying ranges, high speeds, safety when an engine failure occurs, etc.), multi engine propeller driven aircraft are cursed with an undesirable attribute. Vibration and noise will occur when the engines/propellers are not perfectly synchronized in term of rpm. More precisely, passengers and crewmembers are subjected to a thumping beat when the engines are nearly, but not exactly in synchronization. Aside from being an annoyance, protracted exposure to the vibrating pulses may generate problems with avionics equipment, engine baffling, cowlings, fasteners, and other members of the aircraft.

When the aircraft is not equipped with synchronization devices, the pilot manually synchronizes the propellers by carefully positioning the propeller control levers until the pulsating sound is eliminated. This technique has been used since the beginning of multi engine flight. On many four engine airplanes, the crew is able to strobe the propellers into synchronization. To strobe the propellers the pilot first accurately sets the power and rpm settings on the inboard engines (two and three) and coarsely sets the power and rpm on the outboard engines (one and four). As engines two and three are typically mounted slightly forward of engines one and four, the crew is able to view through the blurry propeller disks of engines two and three and observe a portion of the propeller disks for engines one and four. Where the images of the propeller disks overlap, the crew is able to observe a silhouette of the outboard propellers. If the silhouetted propeller blade is stationary, the two propellers are running at the exact same rpm. If the silhouetted blade is drifting clockwise or counterclockwise, the propellers are not in perfect synchronization. When the engines are operating at rpms that are dramatically different, visual harmonics will be seen (e.g., a six bladed silhouetted image for a three bladed propeller).

PROPELLER SYNCHRONIZATION

The principle behind synchronizing propellers during cruise flight primarily involves crew and passenger comfort. Where other benefits previously listed are



Figure 4-1. Twin engine tachometer with synchronizing disk or synchroscope.

also significant, the pulsating droning of “out of sync propellers” expose the occupants in the airplane to a fatiguing flight experience. Airplanes not equipped with synchronization system must still be synchronized during flight as indicated above. Aircraft with tachometers that include a synchronizing disk, or synchroscope, allow the pilot to precisely synchronize the propellers by observing the reaction of the wheel. If the disk is stationary, the propellers are synchronized. On a twin engine airplane, if the wheel rotates in a clockwise direction, the right engine is running faster than the left engine and vice versa if the disk rotates counterclockwise. (Figure 4-1)

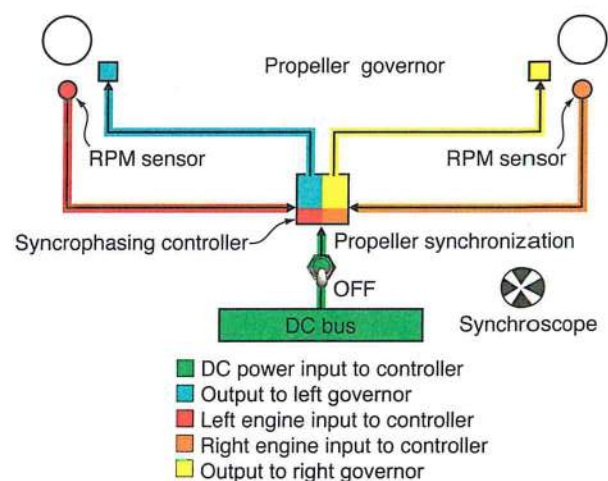

Figure 4-2. Propeller synchronizer and synchrophaser.

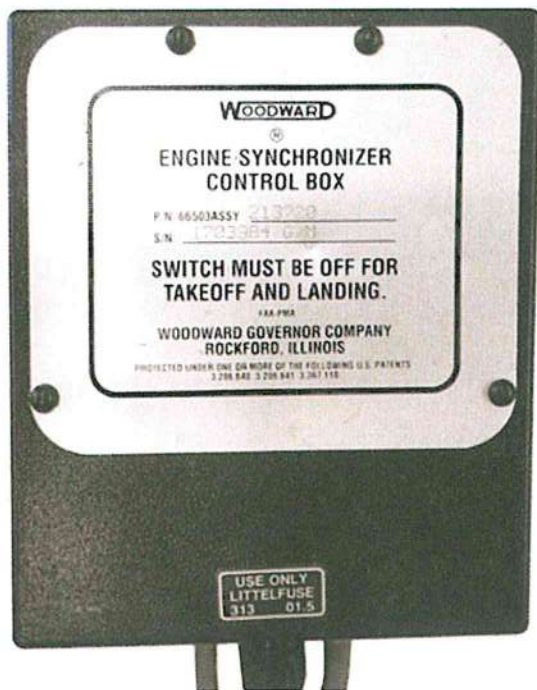

Figure 4-3. Engine synchronizer control box.

To simplify the process of synchronizing engines, many multi engine aircraft, both reciprocating and turboprop powerplants, are outfitted with a synchronization system. When equipped with a Type I system, the aircraft will have a master engine and a slave engine(s). Four engine aircraft may include a selector switch to assign which engine is the master. This is in the event that one of the master engines fail. In such cases the crew may select the other master engine and retain the ability to automatically synchronize the propellers. The master engine is the engine that is emulated by the slave engine(s). To operate the system, the pilot sets the master engine for cruise operation and brings the other engine(s) to within 100 rpm of the master engine setting. When the synchronizer is activated, the slave engine(s) will be set by the system to provide synchronization. The engines will remain in synchronization during the course of the cruise flight, including standard flight maneuvers and turns. The Type I propeller synchronization system is normally in the OFF position during takeoff, landings, single engine operations, slow flight, and stall practice. The pilots operating handbook will provide specific procedures for operations with the synchronizing system. (Figures 4-2 and 4-3)

Type II synchronizing systems do not assign master and slave ranks to the engines. Rather the system will compare the rpms of the engines and raise the speed of

the engines running at a lower rpm. There is a limited range of rpm difference in which the system is able to properly function. This approach to synchronization is considerably different than the Type I design where the slave engine(s) chases the setting of the master engine. Another difference is that Type II systems may be ON during takeoffs and landings. See Figure 3-3 for an example of a Type II governor.

Regardless of which type of propeller synchronization system is mounted on the aircraft, the system will include an rpm sensor for each engine/propeller, a control box/circuit, and the necessary mechanisms to physically change rpm of the target engine(s). The controller compares the rpm of the engines and delivers the necessary input(s) to establish and maintain propeller synchronization. The pilot will normally have to coarsely set the engines to be within approximately 100 rpm of each other before the system will work. Often, the closer the pilot manually sets the engines to each other, the less the system will hunt for the synchronous rpm.

FADEC SYSTEMS

Aircraft equipped with Full Authority Digital Engine Control (FADEC), or similar systems, are generally more sophisticated than those designed without FADEC. The FADEC system will provide synchronization and synchrophasing automatically when the engines are operating in a constant speed mode. The FADEC controllers basically make the necessary adjustments to the engines/fuel controls to save the pilot from this task.

PROPELLER SYNCHROPHASING

Where synchronization contributes much in terms of eliminating the annoying throbbing beat encountered when propellers are not running at the same rpm, having the ability to control the phase relationship between the propeller blades of the engines provides an additional means to deal with noise and vibration during flight. These systems are found on both piston powered aircraft and those with turboprops. They are known as propeller synchrophasing systems.

The process may be a two step procedure. First the propellers are synchronized, then the phase angle of the propellers is altered to provide the least amount of noise and vibration. On a manual synchrophasing system, the pilot will typically rotate a knob until the desired effect is attained. (Figure 4-4)

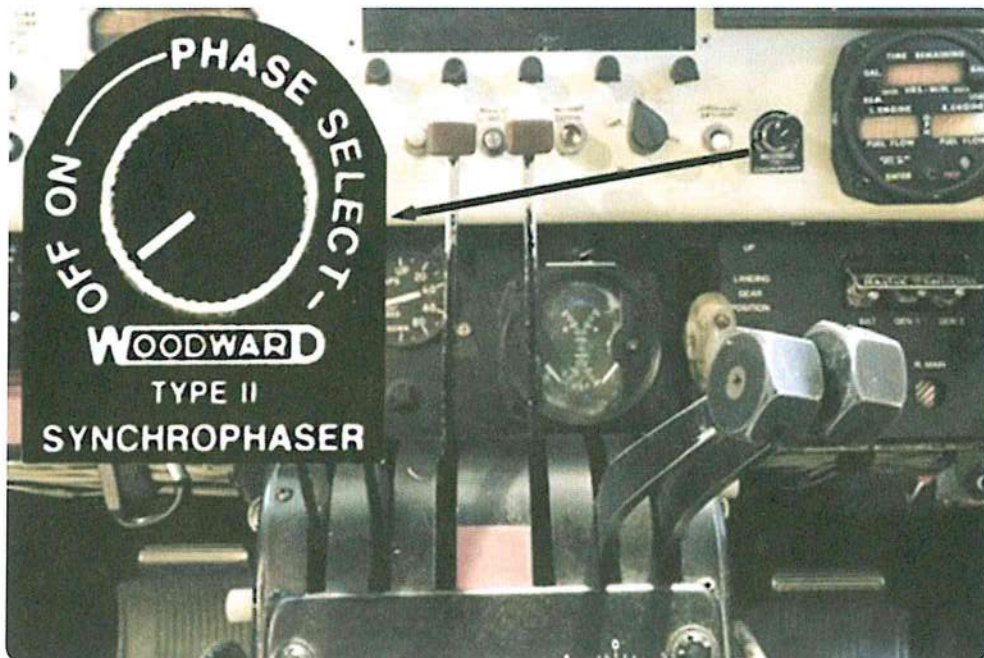

Figure 4-4. Propeller synchrophaser control.

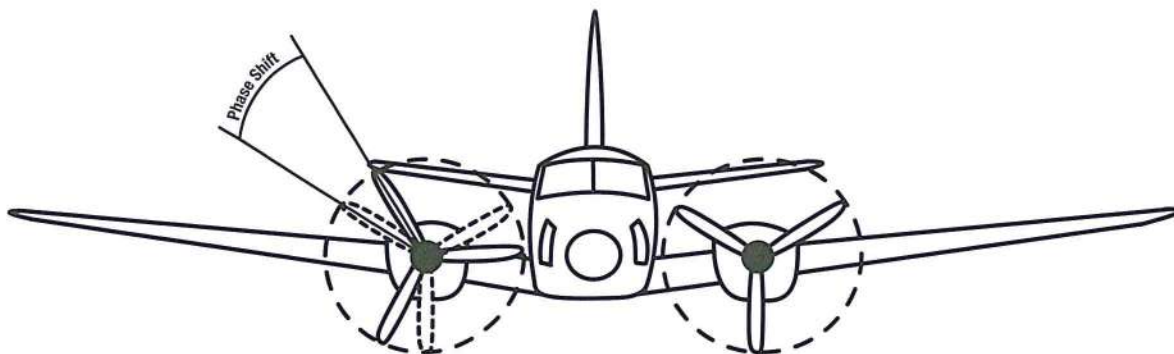

Figure 4-5. Propeller phase altered by synchrophaser.

The basic system uses sensors to determine and monitor the position of a target blade for each propeller (e.g., number one blade). Using electronic circuitry, the controller determines the relationship of the propeller position between the master engine and slave engine(s). By activating the system and rotating the control knob, the phase angle of the slave engine(s) is altered. Once the pilot attains the smoothest and quietest phase angle, the task is complete until the power setting is disturbed. In such cases, the procedure is repeated to reestablish synchronization and synchrophasing.

More sophisticated aircraft will automatically synchronize and synchrophase the propellers. This adds a measure of convenience for the crew and maintains cabin comfort throughout the flight. (Figure 4-5)

TWIN ENGINE SYNCHRONIZER/ SYNCHROPHASER TESTING ON PISTON-POWERED AIRCRAFT

Many light twin-engine aircraft solely rely on the pilot to manually synchronize the engines during flight. As previously presented in this section, some twin engine aircraft are equipped with propeller synchronization systems. More elaborate piston powered, twin engine aircraft have synchrophasing systems to provide an extra measure of cabin environment comfort.

To test the operation of these systems, the following procedure is provided. The information contained herein is for instructional purposes. As always, refer to the appropriate technical data provided by the manufacturer to determine proper, or improper, operation.

Refer to *Figure 4-4*, for an example of the synchronizer/synchrophaser control. Operate the engines at an rpm in which the governors are able to control propeller pitch (e.g., 2 000 rpm). Using the propeller controls, manually synchronize the engines so they are within 40 rpms of each other. Turn the rotary type synchrophaser system switch from the OFF position to the ON position. Slowly rotate the switch within the Phase Select range until the propellers are synchronized. Continuing to rotate the knob within the Phase Select range will alter the phase angle between the propellers while maintaining synchronization. If synchronization is not provided with the system activated, the range of operation may have been exceeded. Reset the propeller controls to limit the rpm spread and repeat the procedure. During flight when power changes are implemented, move both propeller controls simultaneously and repeat the synchronization/synchrophasing process.

SAAB SYNCHRONIZER/ SYNCHROPHASER ON TURBOPROP SYSTEM

The following details the operation and testing of synchronizer/synchrophasing system of a twin engine, Saab turboprop aircraft. It represents a typical system used with multi engine turboprop airplanes.

The synchrophasing system operates using the following equipment: magnetic pickups installed on the propeller gear boxes (PGB), targets for the magnetic pickups mounted on the de-icing slip ring assemblies, synchrophaser control box, electromagnetic coils installed in each propeller control unit (PCU), and control switch and necessary wiring. The system works by measuring rpm differences between the two engines and transmitting a corrective signal to the PCUs.

The target for the magnetic pickup is mounted with the de-icing slip ring assembly. They rotate with the propeller shaft. The pickup is located on the de-icing brush block and works with a coil that provides a signal pulse each time the target aligns with the pickup unit. The pickups remain stationary. The pulses generated as the target sweeps past the pickup are transmitted to the synchrophaser control box. The inputs to the synchrophaser control box are analyzed for rpm and propeller phase relationship. Misalignments in the phase relationship are converted to signals sent to the

trim coils in the PCUs. Synchronizer coils are contained within the PCUs. They produce magnetic fields that act on the flyweight assemblies to control rpm.

OPERATION

The pulses generated are fed into the synchrophaser control box as the moving targets move past the stationary pickups. The pulses produced correspond to the rpm of each propeller. The pulses further provide information on the phase relationship between the propellers. When the rpms between the propellers are not synchronized, the corresponding trim coils in the PCUs are energized to alter propeller blade angle until the propeller rpms are equal.

In order for the system to function, the pilot first manually synchronizes the engine rpm. As the system has a limited range of operation, 2% of the desired rpm, engagement of the synchrophaser system is dependent on accurately synchronizing the rpm before activating the system. Once triggered, the system will raise the rpm of the slow engine and reduce the rpm of the fast engine until they are equal and the desired phase relationship of the propellers is established. The limited range of operation provides a measure of safety as the mechanism will automatically disengage when there is a large difference of rpm between the propellers (e.g., a feathered propeller).

SYSTEM TESTING

To test the operation of the synchrophaser system, the technician first starts the engines and allows for adequate warmup. With the synchrophaser system turned OFF, advance the power levers until the engines are running between 75% to 80% torque. Next, set the rpm of the left engine to 1 300 and the rpm of the right engine to 1 290 using the condition levers. Activate the synchrophaser system by placing the switch in the ON position. The difference in propeller rpm should decrease. Return the synchrophaser switch to the OFF position. Next invert the process by setting the left propeller to 1 290 rpm and the right propeller to 1 300 rpm. Activating the system should produce a reduction in the rpm spread between the two propellers. Deactivate the system before shutting down the engines.

ACTIVE NOISE AND VIBRATION SUPPRESSION SYSTEM

Newer generations of turboprop aircraft, such as the Bombardier Dash 8-Q400, may be equipped with an Active Noise and Vibration Suppression system (ANVS) or (NVS). The performance of the ANVS system normally results in cabin noise levels well below that of conventional turboprop and many jet aircraft. The system works in a fashion similar to noise cancelling headphones.

The designs of newer turboprop aircraft include features to minimize, to the extent possible, the noise generated by the aircraft without the added comfort of the ANVS system. The Q400 uses the six bladed Dowty propeller. The composite blades are rotated at a lower speed, thereby reducing noise when compared to propellers

spinning at higher speeds. Next, the construction of the aircraft contains improved acoustical features that passively reduce noise levels.

As the aircraft achieves propeller synchronization and synchrophasing from the FADEC system, the ANVS system further supplements the reduction in noise level. The ANVS system uses a series of microphones affixed to the exterior of the aircraft. They sense the noise applied to the fuselage. An ANVS controller receives the signal from the microphones. After processing the level and frequency of the noise, the ANVS controller sends a noise-cancelling signal to a group of transmitters strategically placed around the fuselage. The resultant action produces a noise-cancelling effect that significantly reduces cabin noise and vibrations. (Figure 4-6)

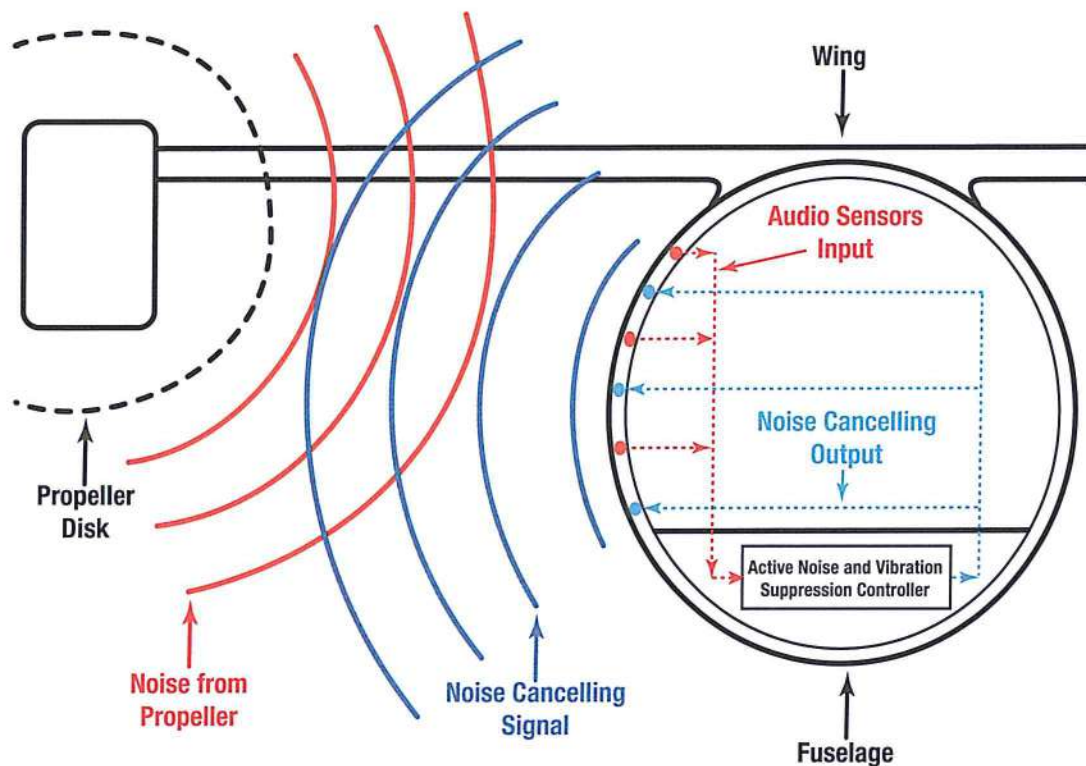

Figure 4-6. Active noise and vibration suppression system.

Question: 4-1

What is the primary purpose of synchronizing propellers on a multi engine aircraft?

Question: 4-5

How is syncrophasing accomplished by the pilot on an aircraft equipped with FADEC engine control?

Question: 4-2

What is the typical way in which a pilot can tell if his propellers are out of synchronization?

Question: 4-6

What additional equalization is accomplished by a syncrophasing system that is not done through basic synchronization?

Question: 4-3

With a type 1 synchronizing system, how is the system adjusted during takeoff and landing?

Question: 4-7

With a syncrophasing system on a piston powered aircraft; what is the indication that proper syncrophasing has been achieved?

Question: 4-4

What is the advantage of syncrophasing the propellers on a twin engine aircraft?

Question: 4-8

Name four methods of reducing cabin noise levels on turboprop aircraft.

ANSWERS

Answer: 4-1

The comfort of the passengers.

Answer: 4-5

The FADEC system does it automatically.

Answer: 4-2

Feels vibration and hears pulsing from the engines.

Answer: 4-6

The position of rotation of the propellers are matched.

Answer: 4-3

It is turned off.

Answer: 4-7

The pilot's perception that vibration, sound, and harmonics have been eliminated.

Answer: 4-4

Additional reduction of noise and vibration.

Answer: 4-8

Synchronizing; syncrophasing; cabin wall insulation; noise cancelling acoustic generators.



PROPELLER

PROPELLER ICE PROTECTION

SUB-MODULE 05

PART-66 SYLLABUS LEVELS

CERTIFICATION CATEGORY →

| A | B1 |
|---|----|
| 1 | 2 |

Sub-Module 05 PROPELLER ICE PROTECTION Knowledge Requirements

17.5 - Propeller Ice Protection

Fluid and electrical de-icing equipment.

Level 1

A familiarization with the principal elements of the subject.

Objectives:

- (a) The applicant should be familiar with the basic elements of the subject.
- (b) The applicant should be able to give a simple description of the whole subject, using common words and examples.
- (c) The applicant should be able to use typical terms.

Level 2

A general knowledge of the theoretical and practical aspects of the subject and an ability to apply that knowledge.

Objectives:

- (a) The applicant should be able to understand the theoretical fundamentals of the subject.
- (b) The applicant should be able to give a general description of the subject using, as appropriate, typical examples.
- (c) The applicant should be able to use mathematical formula in conjunction with physical laws describing the subject.
- (d) The applicant should be able to read and understand sketches, drawings and schematics describing the subject.
- (e) The applicant should be able to apply his knowledge in a practical manner using detailed procedures.

PROPELLER ICE PROTECTION SYSTEMS

Ice formation on propeller blades, in effect, produces altered blade airfoil sections that cause a loss in propeller efficiency. Generally, ice collects, to some measure, asymmetrically on a propeller blade and produces propeller unbalance and harmful vibration and increases the weight of the blades. To minimize the risk of danger associated with propeller icing, systems may be incorporated to either prevent the formation of ice or remove ice that has accumulated on the propeller. The two basic ice protection approaches are: 1) anti-icing systems and 2) de-icing systems.

ANTI-ICING SYSTEMS

As the name implies, anti-icing systems are activated before the formation of ice on the propeller. Once ice builds on the propeller, this system is largely ineffective in removing ice. Accordingly, the anti-icing system must be in operation whenever the aircraft is flying in conditions when ice formation is possible. Depending on ambient conditions and conditions likely to be encountered at altitude during flight, the anti-ice fluid tank may require replenishment before each flight to provide maximum protection against ice formation. (Figure 5-1)

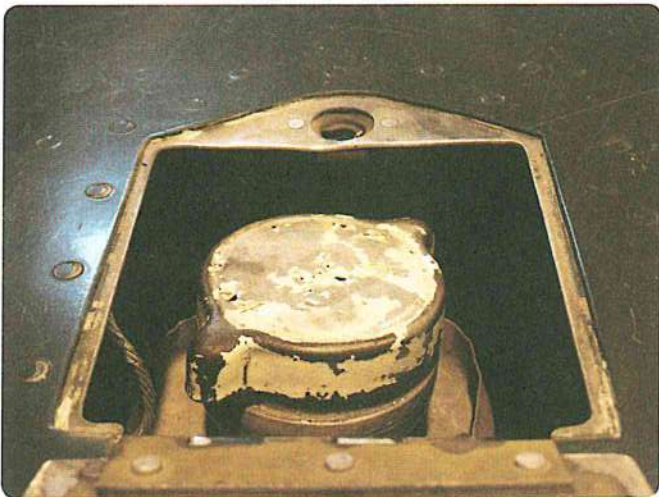

Figure 5-1. Propeller anti-ice fluid tank.

The basic operation of this system is that anti-ice fluid is dispersed to the shank of the propeller blade to mix with moisture in that area. The resultant mixture of the anti-ice fluid and moisture does not readily freeze and prevents the formation and accumulation of ice.

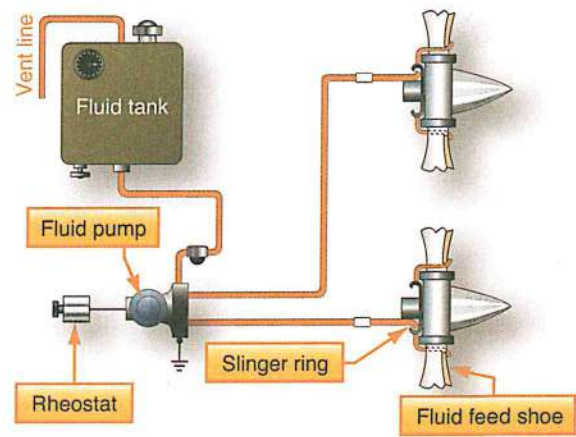

Figure 5-2. Fluid anti-ice system.

A typical fluid system includes a tank to hold a supply of anti-icing fluid. (Figure 5-2) This fluid is delivered to each propeller through the use of a pump. The control system permits variation in the pumping rate so that the quantity of fluid delivered to a propeller can be varied, depending on the severity of icing. A quantity indicator is useful in determining the level of anti-ice fluid and calculating the time remaining in terms of system operation. Fluid is transferred from a stationary nozzle on the engine nose case into a circular U-shaped channel (slinger ring) mounted on the rear of the propeller assembly. (Figure 5-3) Using centrifugal force, the fluid is transferred through the discharge nozzles to each blade shank.

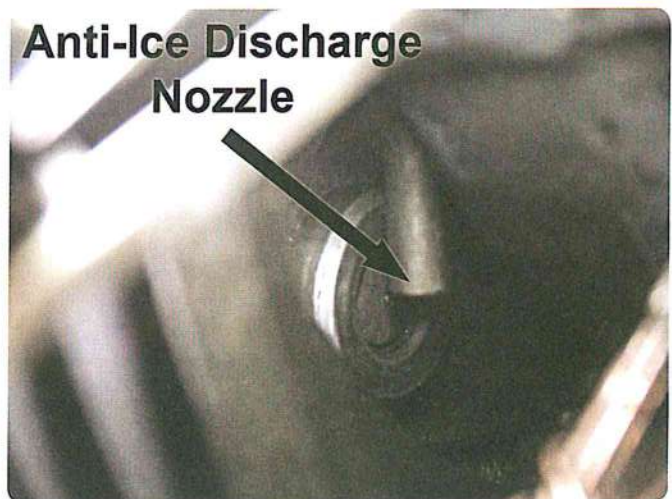

Figure 5-3. Anti-ice fluid discharge into slinger ring.

Because airflow around a blade shank tends to disperse anti-icing fluids to areas where ice does not collect in large quantities, feed shoes, or boots (overshoes), are installed on the blade leading edge to direct the flow of the fluid. These feed shoes are narrow strips of rubber extending from the blade shank to a predetermined

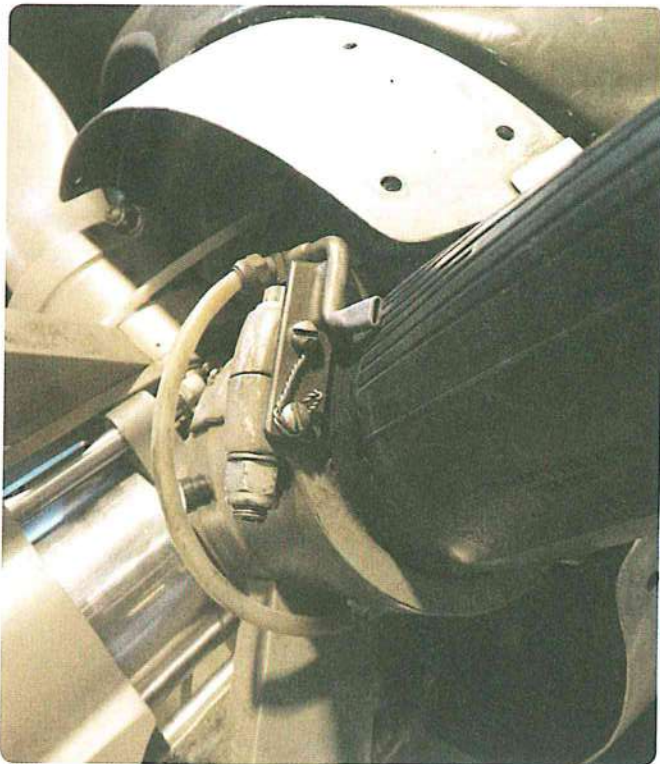

Figure 5-4. Propeller anti-ice discharge nozzle and blade boot.

blade station. The feed shoes are molded with several parallel open channels in which fluid flows from the blade shank toward the blade tip by centrifugal force. The fluid flows laterally from the channels over the leading edge of the blade. (Figure 5-4)

The anti-icing fluid used with this system must readily blend with moisture and produce a solution with an extremely low freezing point to prevent ice build up. Isopropyl alcohol is used in some anti-icing systems because of its availability and low cost. Phosphate compounds are comparable to isopropyl alcohol in anti-icing performance and have the advantage of reduced flammability. However, phosphate compounds are comparatively expensive and, consequently, are not widely used.

To determine proper system operation, the technician should follow maintenance and testing procedures published in the appropriate maintenance manual. It may be necessary to inspect or replace filters and other system components. Aside from determining general operation, a flow test may be used to determine whether the delivery to the propeller complies with specifications. The odor of isopropyl alcohol provides ample evidence of the existence of system leaks on units serviced with that fluid.

The propeller anti-icing system has disadvantages in that it requires several components that add weight to the aircraft, especially the anti-ice fluid contained in the tank. Also, the duration of anti-ice operation available is confined to the amount of fluid on board and the rate of fluid discharge. This system is not used on many aircraft

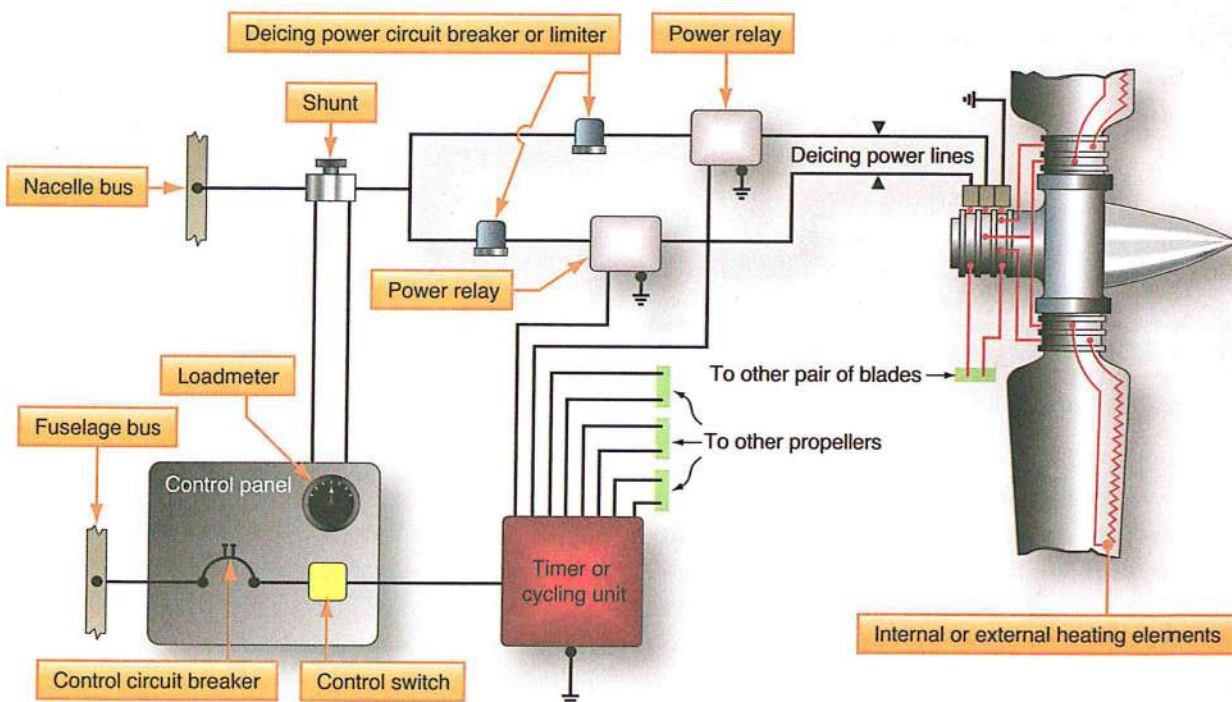

Figure 5-5. Electrical de-icing system.

because of these limitations. Instead, electric de-icing systems have been developed that provide ice protection for the entire duration of the flight, if necessary.

DE-ICING SYSTEMS

An electric propeller icing control system consists of an electrical energy source, a resistance heating element, system controls, and necessary wiring. A typical electrical de-icing system is presented in *Figure 5-5*.

The heating elements are mounted internally or externally on the propeller spinner and blades. Electrical power from the aircraft system is transferred to the propeller hub through electrical leads that terminate in slip rings and brushes. Flexible connectors are used to transfer power from the hub to the blade elements.

A de-ice system consists of one or more on-off switches. The pilot controls the operation of the de-ice system by turning on one or more switches. All de-ice systems have a master switch, and may have another toggle switch for each propeller. Some systems may also have a selector switch to adjust for light or heavy icing conditions or automatic switching for icing conditions.

electricity to the slip ring. A slip ring and brush block assembly is shown in *Figures 5-6 and 5-7*. The slip ring rotates with the propeller and provides a current path to the blade de-ice boots. A slip ring wire harness is used on some hub installations to electrically connect the slip ring to the terminal strip connection screw. A de-ice wiring harness is used to electrically connect the de-ice boot to the slip ring assembly.

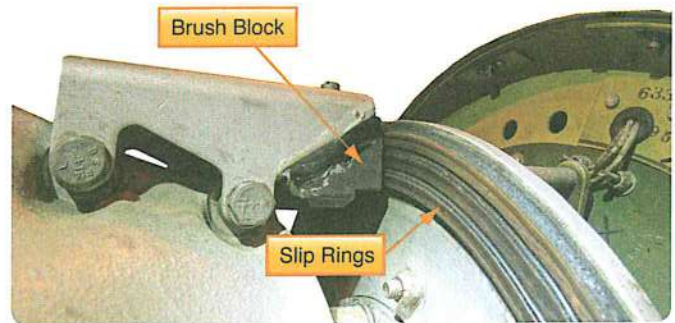

Figure 5-7. Slip rings and brush block.

A de-ice boot contains internal heating elements or dual elements. (*Figure 5-8*) The boot is securely attached to the leading edge of each blade with an adhesive.

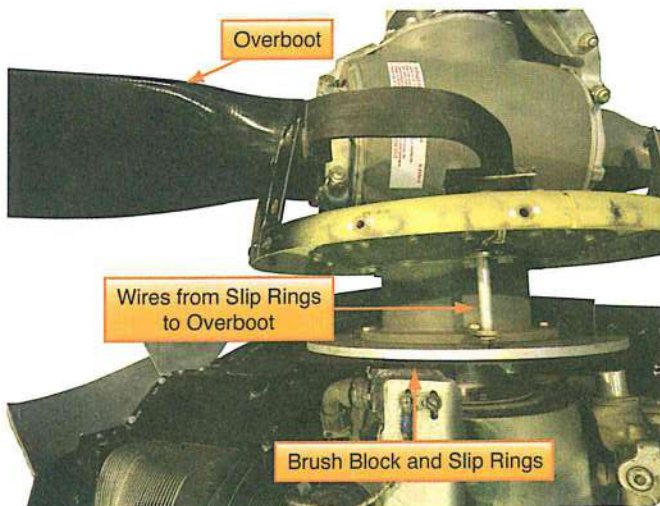

Figure 5-6. Electrical propeller de-icing installation.

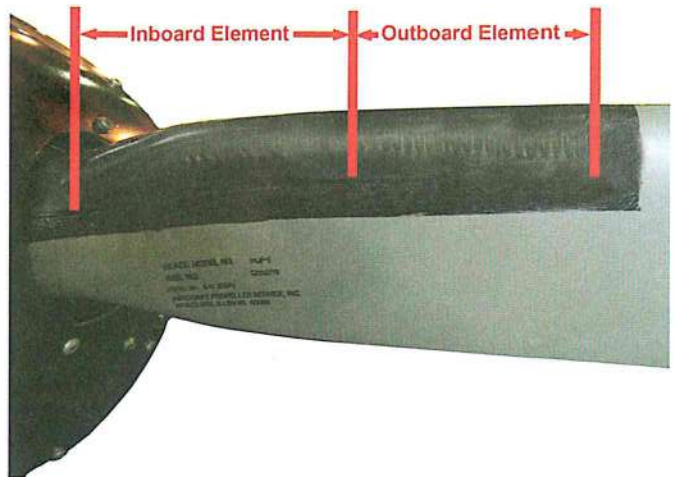

Figure 5-8. De-icing boots or overshoes.

The timer or sequencer unit determines the sequence of which blades (or portion thereof) are currently being de-iced, and for what length of time. The sequencer timer applies power to each de-ice boot, or boot segment, in a sequence or all on order.

A brush block, which is normally mounted on the engine just behind the propeller, is used to transfer

icing control is accomplished by converting electrical energy to heat energy in the heating element. Balanced ice removal from all blades must be obtained as nearly as possible if excessive vibration is to be avoided. To obtain balanced ice removal, variation of heating current in the blade elements is controlled so that similar heating effects are obtained in opposite blades.

Electric de-icing systems are usually designed for intermittent application of power to the heating elements to remove ice after formation but before excessive accumulation. Proper control of heating intervals aids in preventing runback, since heat is applied just long enough to melt the ice accumulation in contact with the blade. If heat supplied to an icing surface is more than that required for melting just the inner ice accumulation, but insufficient to evaporate all the water formed, water will run back over the unheated surface and freeze. Runback of this nature causes ice formation on uncontrolled icing areas of the blade or surface.

As ice is melted or softened, centrifugal force slings the ice from the propeller blades. This often results in the ice striking the side of the fuselage or other parts of the aircraft. The noise associated with this action is disturbing to passengers. To prevent or minimize this scenario, some pilots prefer to activate the de-icing system before the accumulation of ice. They activate the de-icing system when conditions are favorable for ice formation. Under such operations, the system is being used as an anti-icing system.

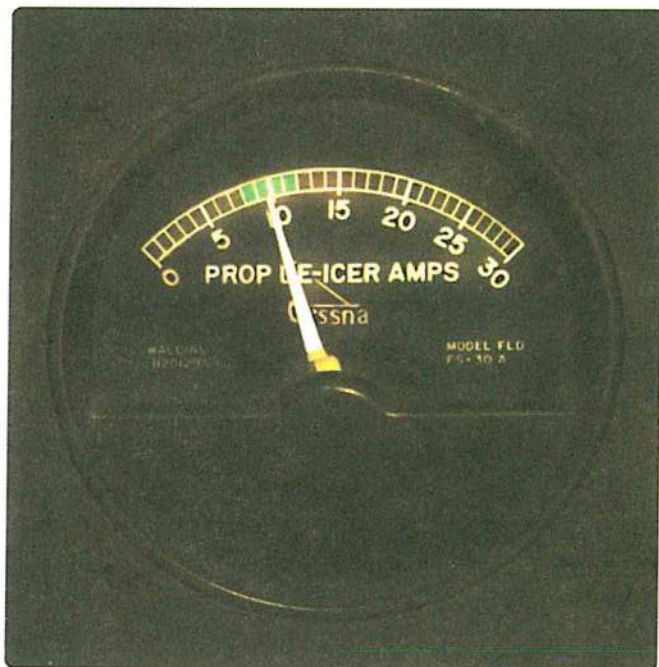

Figure 5-9. Propeller de-icer ammeter. Heating elements should draw green arc current.

Sequencing timers are used to energize the heating element circuits for periods of 15 to 30 seconds, with a complete cycle time of two minutes. A sequencing timer is an electric motor driven contactor that controls power contactors in separate sections of the circuit. Controls

for propeller electrical de-icing systems include on off switches, ammeters or loadmeters to indicate current in the circuits, and protective devices, such as current limiters or circuit breakers. The ammeters or loadmeters permit monitoring of individual circuit currents and reflect operation of the timer. The ammeter should indicate a green arc level of current draw. (Figure 5-9)

As the system changes from one heating element to the next, the ammeter will show a quick deflection in the needle toward zero and back to showing the current draw on the subsequent element receiving power. The normal sequence of heat application begins with the outboard segment of the heating element. Next, the inboard segment is heated. On twin engine aircraft, the propeller on one engine will be de-iced and the system will shift to the other engine after which the sequencer returns to the first engine and the cycle repeats itself.

The sequence of removing ice from the outboard section before heating the inboard element allows the ice on the slower rotating inboard section to sling off the propeller without interference from the ice that would otherwise be accumulated on the outboard section of the de-icing boot. To prevent element overheating, the propeller de-icing system is used only when the propellers are rotating and for short test periods of time during the takeoff check list or system inspection. When the blades are not rotating, there is a lack of cooling air flow passing over the heating elements. Follow testing procedures provided by the manufacturer to determine proper operation.

INSPECTION, MAINTENANCE, AND TESTING ANTI-ICING SYSTEM

Propeller anti-icing systems function by wetting the inboard portions of the propeller blades with an anti-icing fluid (e.g., MIL-F-5566 superseded by TT-I-735A). The fluid mixes with the moisture and greatly reduces the freezing temperature of the water, thereby preventing the formation of ice. A number of maintenance and testing procedures are used to determine proper operation.

Inspection of the system begins with the reservoir. (Figure 5-1) Check for proper anchoring of the tank and adequate sealing by the filling cap. A strong odor will be present should the tank or plumbing possess a leak and the system contains isopropyl alcohol. It may

be necessary to drain and flush the tank on a periodic basis. If draining the system, verify that the quantity indicator reads empty when the tank is depleted. When refilling the tank, check the quantity indication by filling the tank to the $\frac{1}{2}$ level and reading the gauge and rechecking the gauge when the tank is full. (Figure 5-10) Check or replace filters as prescribed in the maintenance instructions. Inspect the pump and any associated check valves for leaks, security of installation, and other defects. Check the plumbing to the slinger rings and discharge nozzles. Inspect the overshoes for condition and proper bonding to the propeller blades.



Figure 5-10. Anti-ice fluid quantity indicator.

For systems with variable delivery rates, a check of the rheostat is performed during the flow check. Airplanes with an anti-icing system may also use the anti-icing fluid for windshield anti-icing operations. Applying anti-icing fluid on the windscreen may have an impact on the available duration of the fluid in the tank. In some systems, when the windshield anti-ice system is activated, the pump runs at the maximum delivery rate, regardless of the position of the rheostat, and anti-icing fluid may be diverted from a propeller (e.g., right propeller) during windshield anti-icing operation. Refer to the appropriate technical data for the aircraft being tested.

To verify fluid consumption perform the flow test, or similar check, as dictated in the maintenance instructions. In this example a twin-engine aircraft has a three U.S. gallon anti-icing fluid tank (384 fluid ounces or 11.4 liters). The rheostat provides a means whereby the pilot may vary the flow through the system based on possible icing conditions. The minimum flow rate for the system provides the maximum duration interval of

3.5 hours of operation. The maximum flow, or minimum duration, is one hour. With the mark on the rheostat knob lined up with the NORM position indicator, two hours of operation are provided by the system. (Figure 5-11) To check the operation of the system, three flow rates are measured. Before testing the system ensure that an adequate quantity of fluid is contained in the tank. Take precautions to prevent fires and have on hand fire fighting equipment should a fire break out. Beware that alcohol fires may be difficult to visually detect.

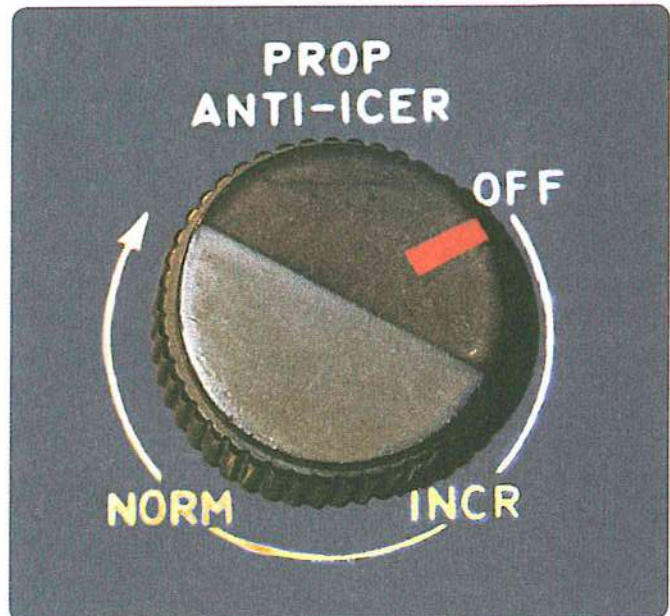

Figure 5-11. Rheostat control on anti-ice with variable flow.

Disconnect the delivery lines going to the slinger rings of each engine. Divert the outputs from the delivery lines to separate containers. Activate the system and capture the output from each system. When turning on the anti-ice system, it is often recommended to initially run the pump at the maximum flow rate for a brief period to establish steady flow before setting the desired rate of delivery.

Rather than running the systems until the tank is depleted, conduct the test for a limited measure of time and calculate flow in units of hours or any other suitable timeframe. In this test, flows will be gathered over six-minute intervals and the flow rate determined by multiplication. At maximum flow rate, each engine should receive 19.2 U.S. fluid ounces (0.57 liters). Using mathematics, 19.2 ounces per engine provides a total delivery of 38.4 ounces over a six-minute period. Multiplying 38.4 ounces by 10 to determine flow rate

per hour yields a flow of 384 fluid ounces or three U.S. gallons (3.4 liters) of flow. At the NORM position, each engine should receive 9.6 U.S. fluid ounces (0.28 liters) over a six minute test. At this flow rate, the total flow over a six minute run equals 19.2 fluid ounces. Multiply by 10 to determine the flow rate per hour. This equals 192 fluid ounces. Dividing 192 into the tank capacity of 384 U.S. fluid ounces indicates that the tank will be depleted in two hours. The test to determine the correct flow at the minimum delivery rate should produce 5.45 fluid ounces per engine over a six minute test or a total of 10.9 fluid ounces for both engines (0.32 liters). Multiplying that figure by 10 provides a 109 fluid ounces delivered over the course of an hour. Dividing 109 ounces per hour into the tank capacity of 384 ounces results in approximately 3.5-hour duration.

INSPECTION, MAINTENANCE, AND TESTING THE ELECTRIC DE-ICING SYSTEM

The typical electrical de-icing system uses power from the aircraft and includes an ON/OFF switch, an ammeter, a sequencing timer or cycling unit, a brush block and slip ring assembly, overshoes with heating elements, and the necessary wiring and hardware. When the system is activated, electrical power travels through the sequencing timer, ammeter, brush block and slip ring assembly to the electrical heating elements embedded in the overshoes. The boots typically use two sets of heating elements, an outboard section and an inboard unit. The heating sequence begins with the outboard element and transfers to the inboard section. *(Figure 5-8)* The time of heat application for the inboard and outboard elements is normally 30 seconds per segment. It is important to heat the outboard section first as any ice on the outboard portion of the boot may physically prevent melted ice on the inboard area from being cast off.

Testing the de-icing system is normally accomplished by activating the switch and observing the ammeter. The current draw on the ammeter should be in the green arc. *(Figure 5-9)* If the current draw is too high, the system could be heating too many elements or have an element with low ohmic value or a wiring fault. If the current draw is too low, the problem may be associated with a defective heating element, a problem at the brush block and slip ring assembly, or a wiring problem. An ammeter reading of zero is likely due to an open circuit or

defective sequencer timer. After 30 seconds of operation, the sequencing timer should switch to the next heating element. This is verified by a momentary fluctuation in the ammeter reading. At the propeller, very carefully touch the heating elements to ensure that the outboard sections of the overshoes on each propeller blades heats up followed by the heating of the inboard sections. Most sequencing timers do not reset each time they are energized. The operation of the system begins where the previous operation stopped. Consequently, it may be necessary to run through the cycle more than once to verify correct sequencing. Check the manufacturer's instructions regarding any time limitations placed on running the test.

BRUSH BLOCK ASSEMBLY

Routine maintenance of the brush block is minimal. During inspections examine the brush block for cleanliness. If deposits of carbon, grease, oil, etc. are found on the brush block assembly, clean the assembly or replace parts, as necessary. If brushes are worn beyond their service limits or have other defects, such as uneven wear or chips, replaced them. Ensure that the brushes have proper alignment and 100% contact with the slip rings.

The brushes wear away as the system accrues hours of operation. Often brushes have limit pins attached so that when they wear beyond their service limits the pins no longer protrude beyond the housing or no longer protrude a prescribed distance beyond the housing. Other units may include holes in the brush block casing that are used to verify whether the brushes have worn beyond their service limits in terms of depth. Measuring the depth that a pin or piece of wire may be inserted into the wear limit holes is used to determine serviceable length of the brushes.

The brushes should be replaced when they are worn beyond their service limits. Be certain to use the correct part number brushes in the proper location as the brushes may have different part numbers. As the slip ring assembly normally has three concentric copper segments, the outboard slip ring has more total surface length and travels at a greater speed than the inboard segments. When replacing the brushes it is common practice to replace the associated springs. Bear in mind that because the spring-loaded brushes remain in constant contact with the slip ring assembly, anytime

the engine is rotating the brushes encounter erosive friction. The brushes may also chatter if the brush block is not critically aligned with the slip rings. The brush block is normally set at a slight angle to the slip rings (e.g., 2°) to minimize brush chattering. This angle may be established by properly inserting a wedge with the correct angle between the brush block and slip ring or by using the appropriate thickness gauges during installation (e.g., 0.07 inches on the right side of the housing and 0.10 inches on the left side of the housing as seen from the front of the engine looking down). Chattering accelerates the wear on brushes. Check the manufacturer's instructions on brush block alignment.

When reinstalling the brush block assembly, ensure that the brushes make complete contact with their associated slip rings. If the contact between the brushes and slip rings is less than 100%, implement the requisite corrective measures (e.g., install or remove alignment shims) to establish complete contact. Refer to the manufacturer's instruction for additional detail concerning brush alignment. Ensure that all attaching hardware is securely installed and safetied.

SEQUENCING TIMER ASSEMBLY

The sequencing timer has proven to be a reliable component. One simple operational test is to activate the system and feel the overshoes to determine whether the boots are heating in the proper sequence of operation. Along with this test, monitor the ammeter (*Figure 5-9*) to verify current draw and duration of each heating operation.

A more complex examination of the sequencer timer is to refer to the wiring schematic to determine which pins are used for the input voltage and ground and which connectors are outputs to the overshoes. By applying system voltage and ground to activate the input circuit, a voltmeter may be used to ascertain sequence of output. The technician must move the voltmeter probe to the proper output pin in the proper order to verify sequence.

RESISTANCE CHECKS

As current draw by the system will largely depend on ohmic resistance, the manufacturer may specify a series of measurements. Each heating element in the overshoe will have a fairly low resistance (e.g., 1 ± 0.5 ohms on a 12-volt system). As the heating elements from each propeller blade are connected in parallel, the ohmic

value for multiple overshoes will be less, approximately $\frac{1}{2}$ for a two bladed propeller and $\frac{1}{3}$ for a three bladed propeller, when the resistance is measured at the slip rings. The resistance will normally be higher when measured at the outlet of the sequencing timer as the resistance of the brushes and slip rings will add to the total ohmic value. Check the appropriate technical documents for specifics regarding resistance checks. In most cases it will be necessary to disconnect plugs and wires, as needed, to obtain accurate readings. Be certain to properly reconnect the wires as crossing the wires at the connections will generate problems in terms of system operation. Recheck the operation of the system at the conclusion of the maintenance procedure.

Deviations from the specified ohmic values indicate a fault. Technicians need to locate the fault and correct the problem (e.g., bad brushes and dirty slip rings, defective heating element in overshoe, open wire from sequencing timer to brush block, etc.). See *Figure 5-5* for a schematic of a typical de-icing system.

REPLACING OVERSHOES

Aside from the brushes, another component of the de-icing system that experiences wear is the overshoe. Damage and wear to the overshoes occur as the boots accrue time in service. Some damage may be repaired according to the manufacturer's information. When the damage is beyond the repairable limit or the heating element embedded in the overshoe becomes defective, the boot may be replaced. The overshoes are commonly replaced during overhaul of the propeller. The following instructions are provided to illustrate the procedures used to replace overshoes of a propeller with metal blades that are still assembled and mounted on the engine. It is important to change the overshoe with the correct replacement part.

Before using solvents to soften the adhesive of the defective boot, mask off the area to protect against chemical damage in unwanted locations. Also, position the propeller blade so that chemical drips will do no harm to other components (e.g., cowling). As in every procedure involving harsh solvents, use protective gear and garments to avoid physical injuries. Also, ensure the work area has adequate ventilation. Take necessary precautions to prevent fires when handling flammable chemicals.

Before beginning the process, take note of how the wires are routed, all wire clamping hardware, and measure the distance between the inboard edge of the boot and blade shank. Digital photographs or hand drawn sketches of the installation may prove useful during the installation and reassembly process. The replacement boot must be properly installed in terms of position and wiring. To initiate the removal of the defective overshoe, apply toluene or methyl-ethyl ketone (MEK) to a corner of the overshoe to debond the edge. Lifting the corner of the boot as the solvent dissolves the adhesive, continue applying the solvent while working free the overshoe. If using a scraper for this process, **use only a nonmetallic scraper** as scratches to the propeller blade in this area may result in blade failure. When a sufficient amount of the overshoe is free of the propeller blade, grasp the loosened corner of the overshoe with pliers or vise-grips and exert a pulling force to the boot while applying the solvent. It may be advantageous to include a soaking period for the solvent to soften the adhesive. Continue pulling the boot away from the propeller blade while applying solvent until the entire boot is free of the propeller blade. Remove any residual adhesive from the propeller blade using the solvent.

Preparing the propeller surface for installation of the replacement boot may vary from one manufacturer to another. The following contains generic steps for the task.

Mask around the area where the overshoe is to be installed. If paint was removed from the propeller surface while removing the overshoe, refinish the surface as specified by the manufacturer (e.g., coat surface with polane paint). Defects in the finish underneath the overshoe may result in poor adhesion

and blade corrosion. The bonding surface must be very clean. Do not use solvents or brushes that contain contaminants. Also, do not touch the surface with bare hands or fingers.

Before attaching the boot, place a temporary alignment mark on the shank of the blade that corresponds with the centerline of the leading edge. This reference mark will be used to center the overshoe on the propeller blade. The centerline on the overshoe is lined up with the centerline of the blade leading edge. Another temporary mark is placed on the blade shank to reveal the edge location of the overshoe. The maintenance manual may contain drawings revealing specific details and measurements when replacing overshoes. Temporarily place the new overshoe in position and wrap it around the leading edge of the propeller blade. Place a temporary mark around the perimeter of the boot approximately ½ inch (13 mm) beyond the edges of the overshoe. After removing the overshoe apply masking material to define outer perimeter of the overshoe. If the area beneath the overshoe has been repainted, it may be necessary to lightly sand the surface to enhance adhesion. Carefully wipe the bonding surfaces of the boot and propeller blade with toluene or MEK with a lint free rag and allow the surfaces to completely dry.

Using the specified bonding agent (e.g., 3M 1300L) apply an even layer of adhesive to the masked off area of the propeller blade and to the interior surface of the overshoe. Allow the adhesive to dry as directed (e.g., one hour). Apply a second coat of adhesive to both surfaces and allow the adhesive to dry, as required (e.g., until faintly sticky). Do not apply the adhesive unless the ambient temperature and humidity requirements are met.

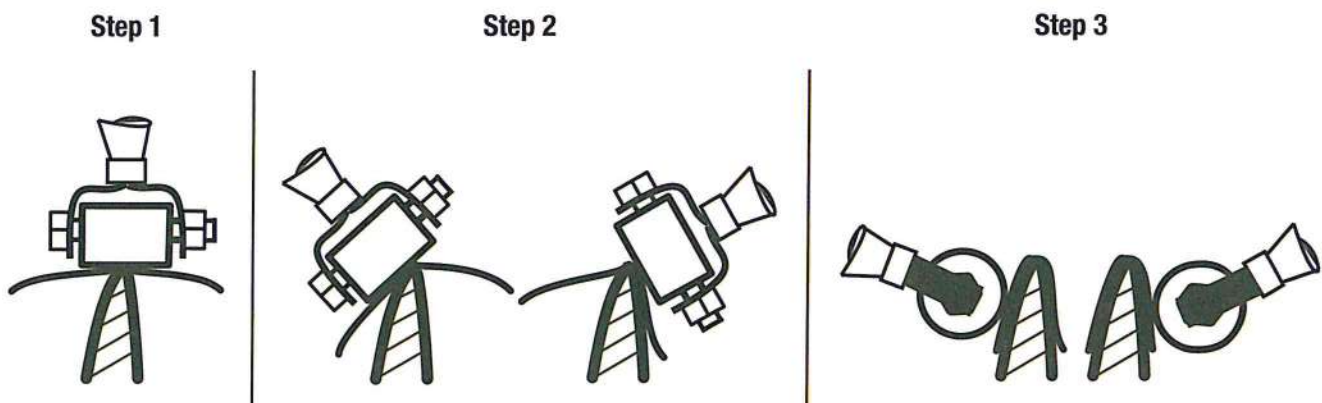

Figure 5-12. Using rubber roller to secure overshoe.

Position the de-icing boot over the mark indicating the starting position on the blade shank and centering the boot with the centerline. Carefully apply the overshoe along the centerline of the leading edge of the blade working from the shank-end toward the propeller tip. Do not wrap the overshoe around the propeller blade until the centerline is established. If necessary, pull the overshoe away from the blade and realign with the centerline of the leading edge. Once in position, use a rubber roller to attach only the leading edge contact area at this time. **Do not use a metal roller as damage to the heating element may occur.** A firm rolling motion is used to ensure a secure bond. Gradually attach the remainder of the boot by working from the leading edge along the blade. Using a slight tipping angle on the roller away from the leading edge, begin attaching the boot to the back and face of the propeller blade. Avoid trapping air between the overshoe and the blade surface. (Figure 5-12) Allow the adhesive to dry the requisite period (e.g., eight hours) before running engine.

After the drying interval, check the bonding of the boot along the perimeter. If improper bonding is found, reapply the adhesive in the loose area and re-roll the overshoe. Allow the adhesive to fully cure and recheck for proper bonding.

To finalize the bonding operation, mask off an area $\frac{1}{2}$ inch (13 mm) beyond the perimeter of the overshoe and $\frac{1}{4}$ inch (6.5 mm) inside the perimeter of the boot. This provides a $\frac{3}{4}$ inch (19 mm) area for the application of a perimeter sealant. (Figure 5-13) The sealant protects the bond line around the edge of the overshoe. Apply the sealant recommended by the manufacturer.

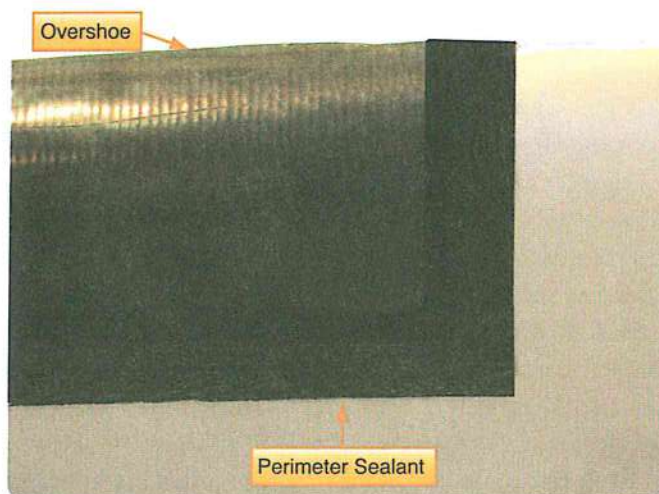

Figure 5-13. Sealant applied to overshoe perimeter.

Reconnect the wires and anchoring devices that protect the wires from the centrifugal force encountered during operation. Check system operation using procedures prescribed in the appropriate manual. A check of the dynamic balance of the propeller may also be appropriate following the replacement of one or more de-icing boots.

QUESTIONS

Question: 5-1

Once propeller anti-ice is delivered to the slinger ring, what transfers the fluid to the blade overshoes?

Question: 5-5

At which flow rates is a rheostat controlled anti-icing system checked?

Question: 5-2

What are the primary disadvantages of a fluid type propeller anti-icing system?

Question: 5-6

On an electric propeller de-icing system, why is the outboard section of the blade heated first?

Question: 5-3

What function is served by the brush block assembly and slip rings of a propeller ice control system?

Question: 5-7

Brush blocks on an electrical de-icing system are routinely checked for what three conditions?

Question: 5-4

During the cycling of an electrical anti-ice system, the prop de-ice ammeter is seen to flicker back and forth. What problem does this indicate?

Question: 5-8

When installing a de-icing boot; name three factors that would adversely affect the adhesive ability of the bonding agent.

ANSWERS

Answer: 5-1

Centrifugal force.

Answer: 5-5

Maximum flow rate; minimum flow rate; normal flow rate.

Answer: 5-2

Limited amount of fluid available; added weight of the fluid.

Answer: 5-6

To allow a clear path for inboard icing to flow off the propeller.

Answer: 5-3

Connect the heating elements of the blade overshoes to the source of electrical power.

Answer: 5-7

Cleanliness; wear; alignment with the slip rings.

Answer: 5-4

This is natural as the cycle progresses from one boot section to another. There is no problem.

Answer: 5-8

Contaminants; air temperature; humidity.



PROPELLER

PROPELLER MAINTENANCE

SUB-MODULE 06

PART-66 SYLLABUS LEVELS

CERTIFICATION CATEGORY →

A **B1**

Sub-Module 06 PROPELLER MAINTENANCE Knowledge Requirements

17.6 - Propeller Maintenance

- Static and dynamic balancing;
- Blade tracking;
- Assessment of blade damage, erosion, corrosion, impact damage, delamination;
- Propeller treatment/repair schemes;
- Propeller engine running.

1

3

Level 1

A familiarization with the principal elements of the subject.

Objectives:

- (a) The applicant should be familiar with the basic elements of the subject.
- (b) The applicant should be able to give a simple description of the whole subject, using common words and examples.
- (c) The applicant should be able to use typical terms.

Level 3

A detailed knowledge of the theoretical and practical aspects of the subject and a capacity to combine and apply the separate elements of knowledge in a logical and comprehensive manner.

Objectives:

- (a) The applicant should know the theory of the subject and interrelationships with other subjects.
- (b) The applicant should be able to give a detailed description of the subject using theoretical fundamentals and specific examples.
- (c) The applicant should understand and be able to use mathematical formula related to the subject.
- (d) The applicant should be able to read, understand and prepare sketches, simple drawings and schematics describing the subject.
- (e) The applicant should be able to apply his knowledge in a practical manner using manufacturer's instructions.
- (f) The applicant should be able to interpret results from various sources and measurements and apply corrective action where appropriate.

PROPELLER INSPECTION AND MAINTENANCE

The propellers are one of the most highly stressed components of an aircraft. As a consequence, propellers must be regularly inspected, maintained, and repaired, as necessary. The propeller and/or aircraft manufacturer commonly specify the exact time intervals and servicing requirements for particular propeller inspections and maintenance operations. The customary daily/preflight inspection of propellers varies little from one type to another. Typically, it is a visual inspection of propeller blades, hubs, controls, accessories for security, safety, leaks, damage, and general condition. Visual inspection of the blades does not mean a slipshod or casual observation. The inspection should be meticulous enough to detect any overt flaw or defect that may exist. Inspections performed at greater intervals of service (e.g., 25, 50, or 100 hours) usually include a detailed visual check of:

1. Blades, spinner, and other external surfaces for excessive oil or grease deposits.
2. Blades, spinner, and hub for nicks, scratches, or other flaws. Use a magnifying glass, if necessary.
3. Spinner or dome shell attaching screws for tightness.
4. The lubricating requirements and oil levels, when applicable.
5. Accumulator charge, when applicable.

If a propeller is involved in an accident, and a possibility exists that internal damage may have occurred, or if a propeller has had a ground/water strike or sudden stoppage, the recommendations of the engine and propeller manufacturers need to be followed. Normally, during such an incident, the propeller is disassembled and inspected. Whenever a propeller is removed, the hub cone seats, cones, and other contact parts, when applicable, should be examined to detect undue wear, galling, corrosion, and other defects.

The propeller inspection requirements and maintenance procedures discussed in this section are representative of those in widespread use on most of the propellers described in this chapter. No attempt has been made to include detailed maintenance procedures for a particular model propeller. All pressures, figures, and sizes are solely for the purpose of illustration and are not directed

at a specific application. For maintenance information on a certain propeller, always refer to applicable manufacturer's instructions.

The inspection of a propeller varies from routine visual inspections to more complex inspections involving dye penetrants, eddy current, ultra sound, coin tap, and magnetic particles. Aside from the type of inspection, the extent of the inspection must also be considered. Inspections range from the pre flight inspection to the detailed inspection that occurs during a maintenance operation to the inspection that takes place when the propeller is being repaired or overhauled.

VISUAL INSPECTION

The most conventional inspection used in aviation is the visual inspection. Aviators routinely examine aircraft and the associated components using the visual inspection technique. As a result, the visual inspection is the first line of assessment regarding airworthiness. Visual inspections may be aided with the use of magnifying glasses, borescopic equipment, and other devices.

TACTILE INSPECTION

Another common inspection approach used on propellers is the sense of touch. Aviators frequently touch areas identified through the visual inspection when the appearance is questionable. Often fingernails will be used to determine the depth or roughness of a suspected area. If passing a fingernail across a damaged area results in the nail "catching" a raised fragment or depressed area of the propeller blade where pitting, scratches, nicks, gouges, or erosion is suspected, the damage may require further investigation and corrective measures.

On variable pitch propellers, the blades should be routinely checked for play. There are four dimension of play that should be checked. Technicians should regularly check variable pitch propeller to determine common levels of movements. Up and down play is checked by grabbing the propeller tip, with the blade in a horizontal position, and trying to move it up and down. If excess force is applied, the engine will rotate. A small amount of play is often detected and allowed if the blade returns to its original position. Grabbing the propeller tip and applying a twisting motion in both directions is used to check for pitch axis play. A slight amount rotation is felt and acceptable on most propellers. In and out, or centrifugal play is checked by grabbing the propeller tip

and trying to push the blade further into the hub and pulling the blade out of the hub. There should be no play when checking the propeller in this dimension. Fore and aft, or thrust play is checked by grabbing the tip of the propeller with both hands and checking for movement. Try moving the blade forward, away from the engine, and backwards, toward the engine. A slight amount of play is generally acceptable. The propeller blade should return to its original position after being released.

BLADE ASSESSMENT

There are numerous types of damage inflicted on aircraft propellers. Aviation professionals need to be aware of these forms of damage and assess whether the unit is airworthy or unsuitable for flight. Throughout the appraisal process, aviators must bear in mind all of the stresses that a propeller withstands during flight. Accordingly, what might appear to be minor in terms of damage may initiate a failure of the propeller. As an example, a deep nick across the leading edge of a propeller blade may evolve into a crack and blade failure. Corrosion is another factor affecting the airworthiness of a propeller. Exposure to high levels of heat, such as a fire, may adversely affect the integrity of the propeller. Aside from steel blades, wooden, aluminum, and composite blades will likely be harmed by exposure to extreme heat. In many instances, failure of the propeller will result in serious consequences. For that reason, the inspection of propellers and the all work performed to propellers must be executed with the utmost care.

When assessing the condition of the propeller blades, erosion along the leading of the blade is common. Because of the high speed of the blade near the tip and the proximity to the surface, more erosion typically is visible near the tip than in the area of the blade shank. Minor levels of erosion on aluminum blades are frequently removed using abrasive paper or with a fine cut file. Care must be taken to retain the original contour of the propeller blade when removing erosion. Refer to the manufacturer's data for limitations regarding removal of blade material.

Impact damage to propeller blades that occurs when the blade strikes an object. Depending on the object struck and the speed of the propeller, impact damage ranges from minor to major. Propellers that have suffered major impact damage will typically need to be replaced, repaired, or overhauled. The engine may also require a sudden stoppage inspection. Minor impact damage,

such as scratches and nicks, are frequently found on propellers. Scratches are usually formed when the propeller is stationary. Examples of scratches include carelessly installing the propeller spinner or engine cowling and scratching the blade shank when sliding the spinner or cowling past the blades. Other scratches may take place when a hard object rubs along the surface to the propeller. Depending on the severity and depth of the scratch, corrective maintenance action may be required. Aviators should take necessary precautions to avoid scratching the propeller.

Nicks and gouges are regularly found on the leading edge and face of propeller blades. In comparison to erosion, nicks and gouges have sharp depressions in the blade material. Depending on the depth and sharpness of the impact damage, the defect may be removed by carefully filing and contouring the blade so that the damaged material is removed and the repaired area has a gentle slope leading to and from the original damaged spot. It is important to remove sharp impressions from the aluminum blades that may otherwise develop into cracks. Corrosion will adversely affect the integrity of a propeller. A propeller may experience surface corrosion on the exterior of the hub and blades and corrosion in the interior area of the hub. When corrosion reaches significant levels, failure of the propeller is a probable outcome. Propeller manufacturers may specify overhaul periods based on calendar time, in addition to time in service, to investigate the severity of corrosion.

Corrosion ranges from more minor forms, such as surface corrosion, to more severe versions (e.g., exfoliation). Surface corrosion on the exterior surface of the propeller is generally visible. The formation of surface corrosion is typically associated with the loss or removal of a protective coating. Polishing propeller blades is generally not recommended because the polishing procedures removes the protective coating on the blade allowing surface corrosion to form. Pitting is a more aggressive form of corrosion. Pitting may be found under decals, boots or overshoes, and reflective tapes used when dynamically balancing the engine. If ignored, the severity of surface corrosion may result in pitting. Intergranular corrosion normally takes place within the grain boundaries of the material. Exfoliation is more associated with improper heat treatment and metal processing. Exfoliation results in metal flaking and severely weakens the component.

Damage to propellers associated with delamination may occur to wooden and composite blades. Where such blades are not at risk to damage from corrosion, the buildup of layers of material that form the blades may become debonded. Damage of this sort may be difficult to detect. Both visual inspections and non destructive testing techniques are useful for discovering delaminations.

Lightning strikes are harmful to aircraft propellers. Such occurrences involve arcing and exposing the affected areas to very high heat. De-icing systems may also suffer damage as a result of a lightning strike. Evidence of burning and missing chunks of the blade are indicators of lightning strikes.

WOOD PROPELLER INSPECTION

Wood propellers should be inspected frequently to ensure airworthiness. Inspect for defects, such as cracks, dents, warpage, glue failure, delamination, defects in the finish, and charring of the wood between the propeller and the flange due to loose propeller mounting bolts. Check for defects in the finish that may allow moisture to be absorbed by the wood. When used, examine the wood close to the metal sleeve of wood blades for cracks extending outward on the blade. These cracks sometimes occur at the threaded ends of the lag screws and may be an indication of internal cracking of the wood.

Check the tightness of the lag screws, which attach the metal sleeve to the wood blade, in accordance with the manufacturer's instructions. Inflight tip failures may be avoided by frequent inspections of the metal cap, leading edge strip, and surrounding areas. Inspect for such defects as looseness or slipping, separation of soldered joints, loose screws, loose rivets, breaks, cracks, eroded sections, and corrosion. Inspect for separation between the metal leading edge and the cap, which would indicate the cap is moving outward in the direction of centrifugal force. Discoloration and loose rivets often accompany this condition. Inspect the tip for cracks by grasping it with the hand and slightly twisting about the longitudinal blade centerline and by slightly bending the tip backward and forward. If the leading edge and the cap have separated, carefully inspect for cracks at this point. Cracks usually start at the leading edge of the blade. Ensure that the moisture holes at the tips are open. A fine line appearing in the fabric or plastic may indicate a crack in the wood. Check the trailing edge of the propeller blades for bonding, separation, or damage.

METAL PROPELLER INSPECTION

Metal propellers and blades are generally susceptible to fatigue failure resulting from the concentration of stresses at the bottoms of sharp nicks, cuts, gouges, and scratches. It is necessary, therefore, to frequently and carefully inspect them for such defects. Visual, fluorescent penetrant, or magnetic particle inspection may be employed to accomplish the inspection of steel blades. The visual inspection is easier if the steel blades are covered with engine oil or rust preventive compound. The full length of the leading edge (especially near the tip), the full length of the trailing edge, the grooves and shoulders on the shank, and all dents and scars should be examined with a magnifying glass to decide whether defects are scratches or cracks.

Carefully inspect aluminum propellers and blades for cracks and other flaws. A transverse crack or flaw of any size is cause for rejection. Multiple deep nicks and gouges on the leading edge and face of the blade is cause for rejection. Use dye penetrant or fluorescent dye penetrant to confirm suspected cracks found in the propeller. Refer any unusual condition or appearance revealed by these inspections to the manufacturer.

DYE PENETRANTS, ETCHING, AND CHROMIC ACID

Dye penetrants commonly used throughout the aviation industry come in two basic formulations, non fluorescent and fluorescent. The non fluorescent penetrant works with ordinary lighting while the fluorescent penetrant requires a black light to perform a thorough investigation. The fluorescent penetrant is commonly preferred. Personnel trained and certificated to perform such operations should conduct dye penetrant inspections. Preparing the area for the dye penetrant inspection is a critical step in the process. If the suspected area to be tested is improperly prepared, the outcome of the procedure could be compromised. Dye penetrant checks are only effective on flaws that extend to the surface. Subsurface defects will not show up using dye penetrant inspections. *(Figure 6-1)*

Etching the propeller blade is a technique that was popular decades ago. It is limited to aluminum parts. Do not etch non aluminum parts. The area to be inspected must be prepared by sanding with smooth

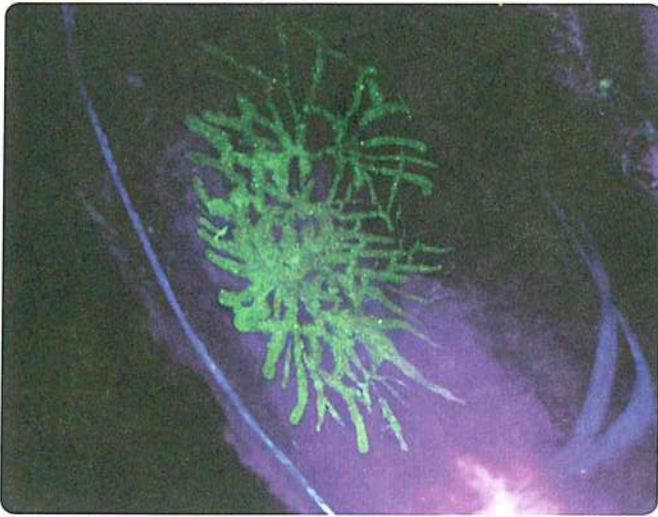

Figure 6-1. Stress corrosion cracking as revealed by fluorescent liquid penetrant inspection.

abrasive paper. Before handling the chemicals, use necessary protective gear. Next, the etching solution, a 20% mixture of sodium hydroxide (lye) is applied to the area using a brush or a swab. Warming the solution before applying it will accelerate the chemical reaction. After the aluminum darkens, wipe away the solution using water. Visually inspect the area. Cracks will appear as black lines as the etching solution that entered the defect will continue to etch the aluminum. To neutralize the etching solution, apply a 20% mixture of nitric acid and wash parts with clean water. Apply the necessary protective finish to the area etched. Like the dye penetrant inspection, etching is for detecting defects that reach the surface.

The chromic acid process is similar to etching save for the chemistry. As with etching, do not apply the chromic acid solution to non aluminum parts. After the application of the chromic acid solution, the parts are thoroughly washed in running water for several minutes and allowed to dry. Cracks will appear as dark lines. Following the chromic acid inspection, the parts are immersed in hot water, near the boiling point, for 30 minutes. This final rinse removes traces of the chromic acid solution. Similar to the etching and dye penetrant checks, the chromic acid inspection is for surface defects.

EDDY CURRENT

As with the dye penetrant inspection and other non destructive testing procedures, the eddy current inspection must be conducted by appropriately

certificated personnel. The eddy current process requires the use of special equipment that induces and appraises an electrical field in the part being examined. With the proper probes and techniques, eddy current tests may detect both surface and subsurface defects. Subsurface defects need to be relatively near the surface to be detected. This inspection technique may be used on both ferrous and non ferrous metals.

ULTRA SOUND

Ultrasonic inspections are versatile. They may be used on ferrous and non ferrous metals as well as wood and composite materials. The person conducting the ultra sound inspection must be certificated and the proper probes and techniques utilized. The ultra sound technique projects a sound wave into the material. The machine analyzes the reaction to the sound wave to determine the condition of the material. Defects at and below the surface may be detected using this technique.

MAGNETIC PARTICLES

Properly trained and certificated personnel should be used to perform magnetic particle inspections of propeller parts. This type of inspection is only used on ferromagnetic parts and is capable of detecting surface and subsurface defects. The process magnetizes the part being inspected. The application of fine magnetic particles will reveal defects existing in the part. Both fluorescent and non fluorescent magnetic particles are available. As with other inspections involving fluorescent particle, the process requires a special light during the inspection. (Figure 6-2)

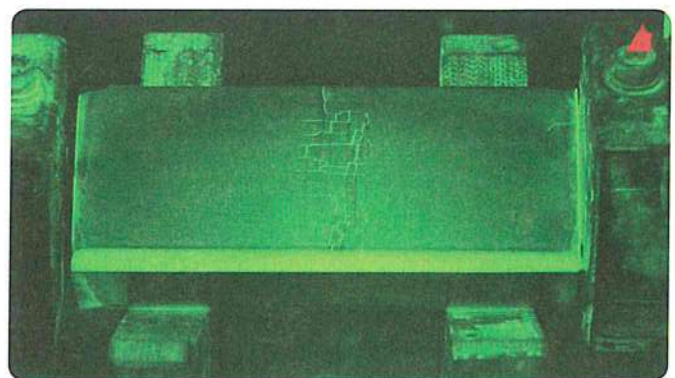

Figure 6-2. Cracking within a ferrous metal as revealed by magnetic particle inspection.

COMPOSITE PROPELLER INSPECTION

Composite blades need to be visually inspected for nicks, gouges, loose material, erosion, cracks and debonded areas, and lightning strikes. (Figure 6-3) Composite blades are inspected for delaminations and debonds by tapping the blade or cuff (if applicable) with a metal coin. If an audible change is apparent, sounding hollow or dead, a debond or delamination is likely. (Figure 6-4) Blades that incorporate a “cuff” have a different tone when coin tapped in the cuff area. To avoid confusing the sounds, coin tap the cuff area and the transition area between the cuff and the blade separately from the blade area. Additional nondestructive testing (NDT) techniques for composite materials, such as phased array inspections, and ultrasound inspections, are available for more detailed inspections.

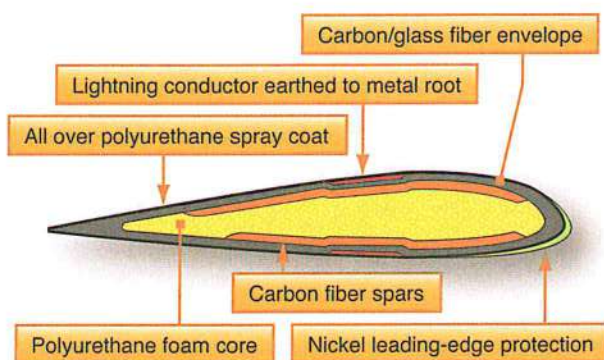

Figure 6-3. Composite propeller blade cross section.

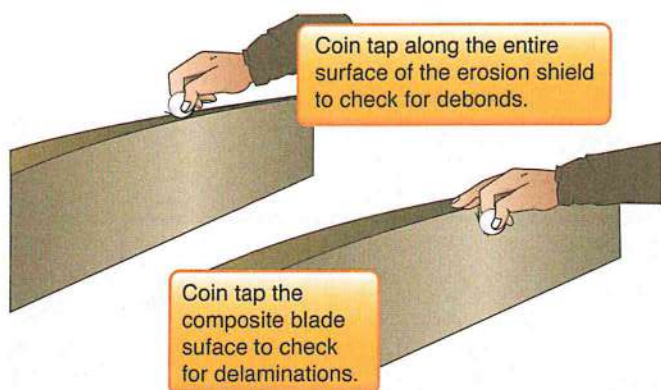

Figure 6-4. Checking composite propeller blade using coin tap test.

Repairs to propellers are often limited to minor type repairs. Certificated mechanics are not allowed to perform major repairs on propellers. Major repairs need to be accomplished by the propeller manufacturer or certificated propeller repair station.

COIN TAP

Using a coin or similar device to tap the surface of laminated material may be used to discover delaminations. Where the laminates are securely bonded, a solid sound will be heard with the tapping action. Areas of delaminations will have a hollow sound when tapped. Specialized tapping hammers may be used for this test, but often a large coin will work as a readily available substitute.

BLADE TRACKING

Blade tracking is the process of determining the positions of the tips of the propeller blades relative to each other (blades rotating in the same plane of rotation). Tracking shows only the relative position of the blades, not their actual path. The blades should all track one another as closely as possible. The difference in track at like points must not exceed the tolerance specified by the propeller manufacturer. The design and manufacture of propellers is such that the tips of the blades give a good indication of tracking. Mishandling propellers, a bent propeller flange, improperly tightened retention hardware, and other similar damage may disturb the blade track. Propellers that are significantly out of track may also be difficult to dynamically balance. The following method for checking propeller blade track is normally used:

1. Chock the aircraft so it cannot be moved.
2. Remove one spark plug from each cylinder. This makes the propeller easier and safer to turn.
3. Rotate one of the blades so it is pointing down.
4. Place a solid object (e.g., a heavy wooden block that is at least a couple of inches higher off the ground than the distance between the propeller tip and the ground) next to the propeller tip so that it just touches or attaches a pointer/indicator to the cowling itself. (Figure 6-5)
5. Rotate the propeller slowly to determine if the next blade tracks through the same point (touches the block/pointer). Each blade track should be within 1/16 inch (plus or minus) from the opposite blade's track.
6. An out of track propeller, may be due to one or more propeller blades being bent, a bent propeller flange, or propeller mounting bolts that are either over or undertorqued. An out of track propeller causes vibration and stress to the airframe and engine and may cause premature propeller failure.

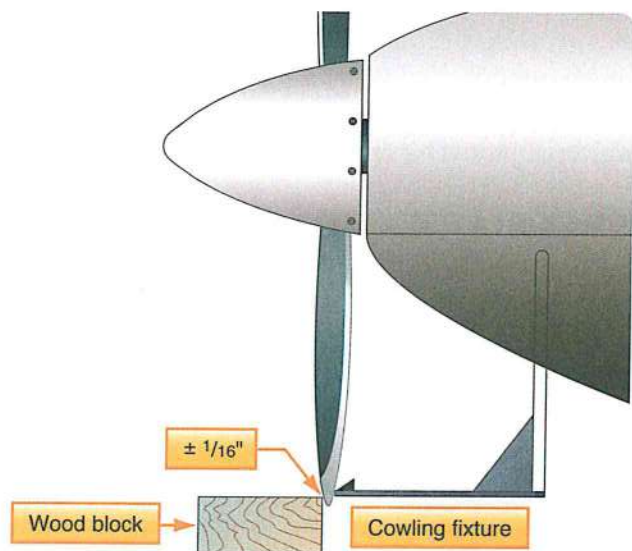

Figure 6-5. Checking propeller blade track.

CHECKING AND ADJUSTING PROPELLER BLADE ANGLES

When you find an improper blade angle setting during installation or indicated by engine performance, follow basic maintenance guidelines. From the applicable manufacturer's instructions, obtain the blade angle setting and the station at which the blade angle is to be checked. Do not use metal scribes or other sharply pointed instruments to mark the location of blade stations or to make reference lines on propeller blades, since such potential surface scratches can eventually result in blade failure. A piece of adhesive tape is adequate for marking the appropriate blade station. Use a benchtop protractor if the propeller is removed from the aircraft. (Figure 6-6) Use a handheld protractor (a digital protractor provides an easy measurement) to check blade angle if the propeller is installed on the aircraft or is placed on the knife edge balancing stand. (Figure 6-7)

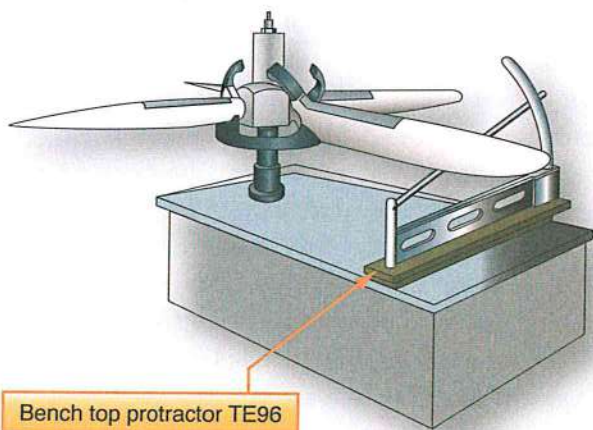

Figure 6-6. Blade angle measurement with bench-top protractor.

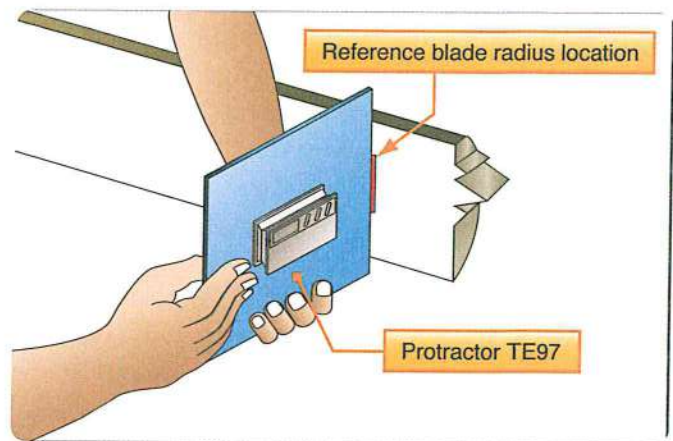

Figure 6-7. Blade angle measurement with handheld protractor.

UNIVERSAL PROPELLER PROTRACTOR

The universal propeller protractor can be used to check propeller blade angles when the propeller is on a balancing stand or installed on the aircraft engine. It may also be used for measuring other parts of an aircraft, such as flight control deflection. Figure 6-8 shows the parts and adjustments of a universal propeller protractor. The following instructions for using the protractor apply to a propeller installed on the engine:

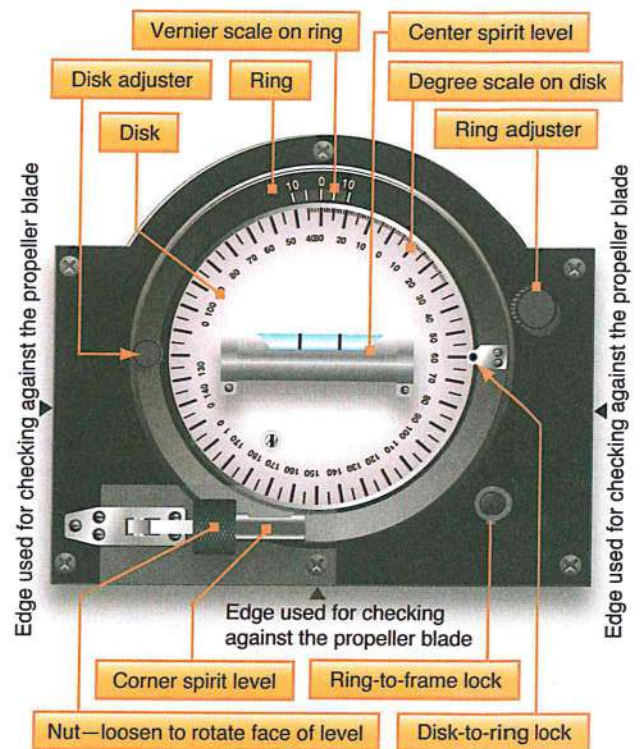

Figure 6-8. Universal protractor.

Turn the propeller until the first blade to be checked is horizontal with the leading edge up. Place the corner spirit level at right angles to the face of the protractor. Align degree and vernier scales by turning the disk adjuster so that the disk is locked to the ring. The locking device is a pin that is held in the engaged position by a spring. The pin can be released by pulling it outward and turning the knob 90°. Release the ring to frame lock (a right hand screw with thumb nut) and turn the ring until both ring and disk zeros are at the top of the protractor.

Check the blade angle by determining how much the flat side of the block slants from the plane of rotation. First, locate a point to represent the plane of rotation by placing the protractor vertically against the end of the hub nut or any convenient surface known to lie in the plane of propeller rotation. Keep the protractor vertical by the corner spirit level, and turn the ring adjuster until the center spirit level is horizontal. This sets the zero of the vernier scale at a point representing the plane of propeller rotation. Then, lock the ring to the frame.

While holding the protractor by the handle with the curved edge up, release the disk to ring lock. Place the forward vertical edge (the edge opposite the one first used) against the blade at the station specified in the manufacturer's instructions. Keep the protractor vertical by the corner spirit level, and turn the disk adjuster until the center spirit level is horizontal. The number of degrees and tenths of a degree between the two zeros indicates the blade angle.

In determining the blade angle, remember that ten points on the vernier scale are equal to nine points on the degree scale. The graduations on the vernier scale represent tenths of a degree, but those of the degree scale represent whole degrees. The number of tenths of a degree in the blade angle is given by the number of vernier scale spaces between the zero of the vernier scale and the vernier scale graduation line nearest to perfect alignment with a degree scale graduation line. This reading should always be made on the vernier scale. The vernier scale increases in the same direction that the protractor scale increases. This is opposite to the direction of rotation of the moving element of the protractor. After making any necessary adjustment of the blade, lock it in position and repeat the same operations for the remaining blades of the propeller.

Before using the universal protractor for the first time on an aircraft, technicians should take some practice readings to learn how to use the tool. Accurate use of the universal protractor takes a little practice.

PROPELLER VIBRATION

Although vibration can be caused by the propeller, there are numerous other possible sources of vibration that can make troubleshooting difficult. If a propeller vibrates, whether due to balance, angle, or track problems, it typically vibrates throughout the entire rpm range, although the intensity of the vibration may vary with the rpm. If a vibration occurs only at one particular rpm or within a limited rpm range (e.g., 2 200 to 2 350 rpm), the vibration is not normally a propeller problem but a problem of a poor engine/propeller match. Check the tachometer for a red arc denoting a vibratory range. If a propeller vibration is suspected but cannot be positively determined, the ideal troubleshooting method is to temporarily replace the propeller with one known to be airworthy and then test fly the aircraft, if possible. Blade shake is not the source of vibration problems.

Once the engine is running, centrifugal force holds the blades firmly (approximately 30 000–40 000 pounds) against blade bearings of controllable-pitch propellers. Cabin vibration can sometimes be improved by reindexing the propeller on the crankshaft or propeller shaft. The propeller can be removed, rotated 180°, and reinstalled. The propeller spinner can be a contributing factor to an out of balance condition. An indication of this would be a noticeable spinner wobble while the engine is running. Inadequate shimming of the spinner front support or a cracked or deformed spinner usually causes this condition. Fault with the engine mount system may add to the level of vibration.

When power plant vibration is encountered, it is sometimes difficult to determine whether it is the result of engine vibration or propeller vibration. In most cases, the cause of the vibration can be determined by observing the propeller hub, dome, or spinner while the engine is running within a 1 200- to 1 500-rpm range, and determining whether or not the propeller hub rotates on an absolutely horizontal plane. If the propeller hub appears to swing in a slight orbit, the vibration is usually caused by the propeller. If the propeller hub does not appear to rotate in an orbit, the difficulty is probably

caused by engine vibration. The vibration may be a combination of engine and propeller issues.

When propeller vibration is the reason for excessive vibration, the difficulty is usually caused by propeller blade imbalance, propeller blades not properly tracking, or variation in propeller blade angle settings. Check the propeller blade tracking and then the low pitch blade angle setting to determine if either is the cause of the vibration. If both propeller tracking and low blade angle setting are correct, the propeller is statically or dynamically unbalanced and should be replaced, or rebalanced if permitted by the manufacturer.

PROPELLER BALANCING

Propeller unbalance, which is a source of vibration in an aircraft, may be either static or dynamic. Propeller static imbalance occurs when the center of gravity (CG) of the propeller does not coincide with the axis of rotation. Dynamic unbalance results when the CG of similar propeller elements, such as blades or counterweights, does not follow in the same plane of rotation. Since the length of the propeller assembly along the engine crankshaft is short in comparison to its diameter, and since the blades are secured to the hub so they lie in the same plane perpendicular to the running axis, the dynamic unbalance resulting from improper mass distribution is negligible, provided the

track tolerance requirements are met. Another type of propeller unbalance, aerodynamic unbalance, results when the thrust (or pull) of the blades is unequal. This type of unbalance can be largely eliminated by checking blade contour and blade angle settings and correcting associated problems.

STATIC BALANCING

The knife edge test stand has two hardened steel edges mounted to allow the free rotation of an assembled propeller between them. (*Figure 6-9*) The knife edge test stand must be located in a room or area that is free from any air motion, and preferably removed from any source of heavy vibration.

The standard method of checking propeller assembly balance involves the following sequence of operations:

1. Insert a bushing in the engine shaft hole of the propeller.
2. Insert a mandrel or arbor through the bushing.
3. Place the propeller assembly so that the ends of the arbor are supported upon the balance stand knife edges. The propeller must be free to rotate.

If the propeller is properly balanced statically, it remains stationary at any position in which it is placed. Check two bladed propeller assemblies for balance: first with the blades in a vertical position and then with the blades

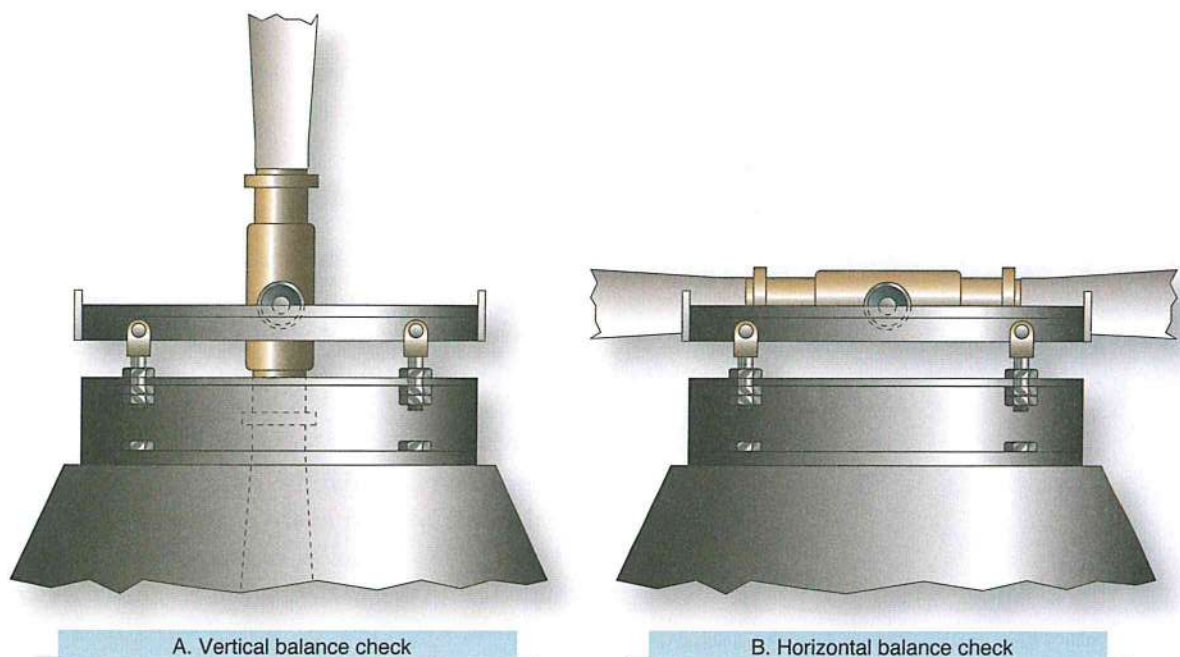

Figure 6-9. Checking two bladed propeller for static balance using knife-edge stand.

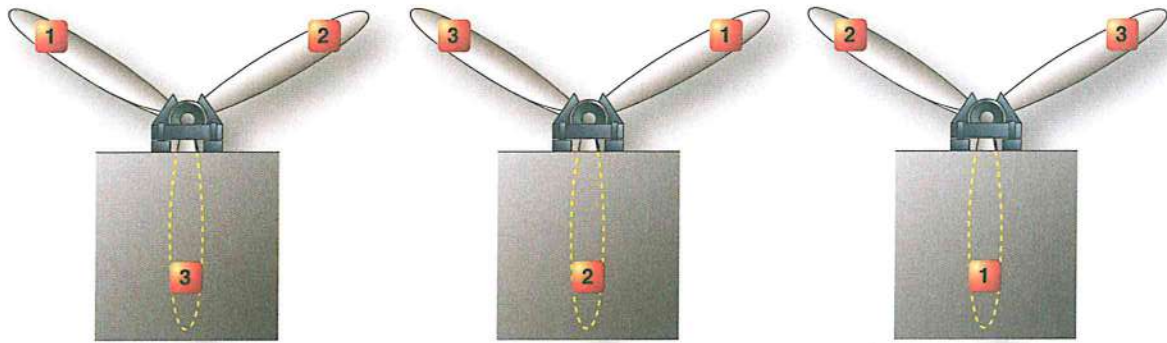

Figure 6-10. Checking three bladed propeller for static balance using knife-edge stand.

in a horizontal position. Repeat the vertical position check with the blade positions reversed; that is, with the blade that was checked in the downward position placed in the upward position.

Check a three bladed propeller assembly with each blade placed in a downward vertical position. (Figure 6-10)

During a propeller static balance check, all blades must be at the same blade angle. Before conducting the balance check, inspect to see that each blade has been set at the same blade angle.



Figure 6-11. Checking three-bladed propeller for static balance with blade in other-than-vertical position using knife-edge stand.

Unless otherwise specified by the manufacturer, an acceptable balance check requires that the propeller assembly has no tendency to rotate in any of the positions previously described. If the propeller balances perfectly in all described positions, it should also balance perfectly in all intermediate positions. When necessary, check for balance in intermediate positions to verify the check in the originally described positions. (Figure 6-11)

When a propeller assembly is checked for static balance and there is a definite tendency of the assembly to rotate, certain corrections to remove the unbalance are allowed. The addition of permanent fixed weights at acceptable locations when the total weight of the propeller assembly or parts is under the allowable limit.

The removal of weight at acceptable locations when the total weight of the propeller assembly or parts is equal to the allowable limit.

The location for removal or addition of weight for propeller unbalance correction has been determined by the propeller manufacturer. The method and point of application of unbalance corrections must be checked to see that they are according to applicable technical information.

DYNAMIC BALANCING

Propellers can also be dynamically balanced (spin balanced) with an analyzer kit to reduce the vibration levels of the propeller and spinner assembly. Dynamic balancing, with electronic tracking, is commonly used on rotorcraft to reduce vibrations generated by the main and auxiliary rotors. Some aircraft have the system hardwired in the aircraft and on other aircraft

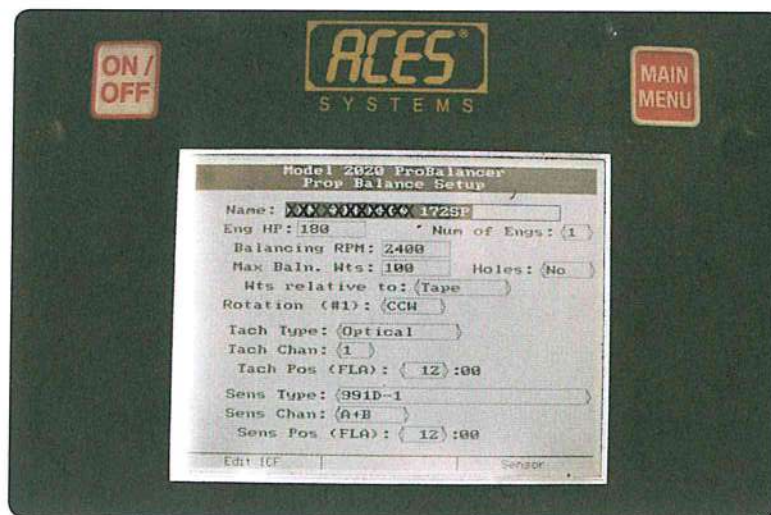

Figure 6-12. Setting up dynamic balancer before making engine runs.

the sensors and cables need to be temporarily installed before the balancing process. Balancing the propulsion assembly can provide substantial reductions in transmitted vibration and noise to the cabin that serve to reduce fatigue to the crew and passengers. Minimizing the level of vibration also reduces excessive damage to other aircraft, avionics, and engine components. The dynamic imbalance could be caused by mass, or weight, imbalance or any aerodynamic imbalance. Dynamic balancing only reduces the vibration caused by weight unbalance of the externally rotating components of the propulsion system. Balancing does not effectively reduce the vibration level if the engine or aircraft is in poor mechanical condition. Defective, worn, or loose parts will make balancing very difficult if not impossible. Several manufacturers make dynamic propeller balancing equipment, and their equipment operation may differ from one unit to the next. The typical dynamic balancing system consists of a vibration sensor that is attached to the engine close to the propeller, a photo tachometer sensor to assign clock position of the propeller and sense rpm, and an analyzer unit that measures the level and location of the vibration and rpm of the propeller. The analyzer also calculates the weight and location of the corrective balancing weights. Often a second vibration sensor is affixed to the rear of the engine to help identify engine vibrations. (Figure 6-12)

BALANCING PROCEDURE

Visually inspect the propeller assembly before dynamic balancing. The first run up of a new or overhauled propeller assembly may leave a small amount of grease

on the blades and inner surface of the spinner dome. Use stoddard solvent (or equivalent) to completely remove any grease on the blades or inner surface of the spinner dome. Visually examine each propeller blade assembly for evidence of grease leakage. Visually examine the inner surface of the spinner dome for evidence of grease leakage. If there is no evidence of grease leakage, lubricate the propeller in accordance with the maintenance manual. If grease leakage is evident, determine the location of the leak and correct before relubricating and dynamic balancing the propeller. Before dynamic balancing, record the number and location of all balance weights. Static balance is accomplished at a propeller overhaul facility when an overhaul or major repair is performed. Normally, those performing dynamic balancing do not disturb the original weights used for static balancing and will install weights on other rotating components, such as the starter ring gear of a Lycoming power plant or on the propeller spinner bulkhead.



Figure 6-13. Weight added to Lycoming starter ring gear.

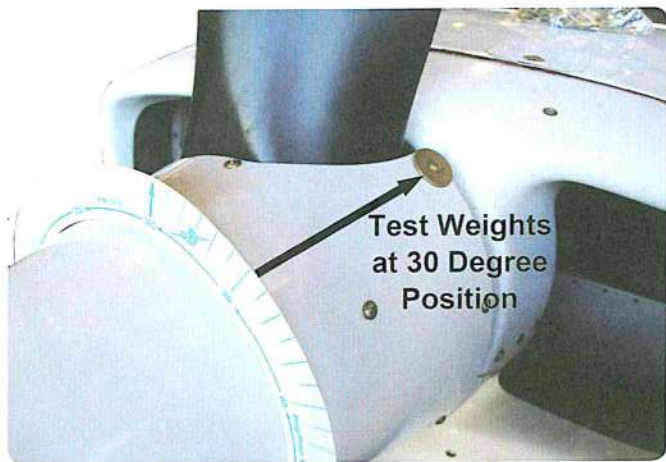

Figure 6-14. Using special protractor to determine location in reference to 12 O'Clock blade, test weight is added to spinner screw. DO NOT FLY aircraft with test weights installed. Analyzer will calculate new weight package for permanent installation location on spinner bulkhead.

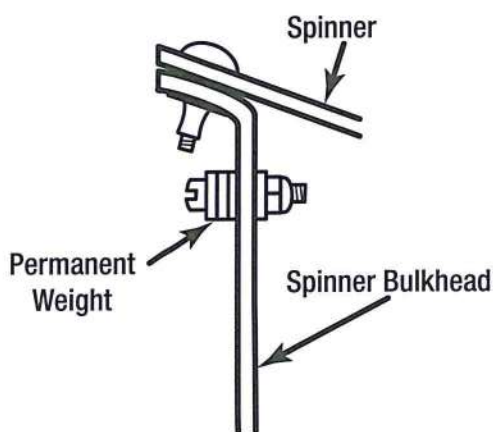

Figure 6-15. Sample permanent weight installation on spinner bulkhead.

On the starter ring gear of a Lycoming power plant, twelve equally spaced locations are available for weight attachment. Install the balancing weights using aircraft quality bolts, washers, and nuts. On the Lycoming starter ring gear, install the bolt with the head facing the engine. Do not add washers under the bolt head as the latter may strike the starter assembly housing. Ensure that the threads of the bolt protrude beyond the self locking feature of the nut (*Figure 6-13*). If balance weight screws are to be attached to the spinner bulkhead, they must protrude through the self locking nuts or nut plates a minimum of one thread and a maximum of four threads. When placing test weights under the screws securing the spinner, the use of a protractor may be required to identify weight location. (*Figure 6-14*) As the test weights used in conjunction with the spinner screws are only for determining balancing needs, the weight equivalent must be calculated and applied to

a hole drilled in the spinner bulkhead. (*Figure 6-15*) As this process typically alters the balancing outcome, the technician will recheck the dynamic balance and alter weight at the permanent location in the spinner bulkhead to produce the optimum balancing outcome. Always double check the dynamic balancing after the final weights have been added to or removed from the rotating components.

Unless otherwise specified by the engine or airframe manufacturer, Hartzell recommends that the propeller be dynamically balanced to a reading of 0.2 ips (inch per second), or less. If reflective tape is applied to the propeller for use with the photo tachometer sensor, remove the tape immediately after balancing is completed. Leaving the tape on the propeller may spawn corrosion on the blade. Make a record in the propeller logbook regarding the number and location(s) of dynamic balance weights, and static balance weights if they have been reconfigured. Most dynamic balancing operations recommend the installation of a placard informing other maintenance technicians that the propeller has been dynamically balanced.

To balance the propeller, face the aircraft directly into the wind (maximum 20 knots) and chock the wheels. It may be difficult to perform this operation during gusty wind conditions. Make certain that the propeller blast will not damage other aircraft, equipment, property, or molest personnel. During the installation of the sensors, the technician must be careful to avoid hazards that may damage the equipment or aircraft. In particular, cables should not come into contact with rotating components or members of the exhaust system and should be securely anchored using tape, tie wraps, Velcro straps, elastic bands, or other suitable devices. Wires should not be allowed to whip within the propeller blast area as such action is detrimental to the cables and may damage the aircraft finish. Most balancing systems use a special reflective tape applied to a propeller blade in conjunction with the photo tachometer sensor to establish the compass position with the analyzer (normally placed at the 12 o'clock position) and propeller rpm. (*Figure 6-16*) Before starting the engine undertake the procedure to ensure that the photo tachometer sensor is correctly aimed at the tracking tape on the propeller blade. It is generally preferred to install two accelerometers or velocimeters on the engine, one near the propeller and another on or near the accessory case. (*Figure 6-17*)

| Test Run | Engine RPM | Vibration (IPS) | Location Degrees | Influence Grams/Vibe | Location Degrees | Recommended Solution Grams | Recommended Location Degrees | Actual Installation Grams | Actual Location Degrees |
|----------|------------|-----------------|------------------|----------------------|------------------|----------------------------|------------------------------|---------------------------|-------------------------|
| 1 | 2388 | 0.56 | 151° | 39.1g | 270° | 21.8g | 241° | 21.8g | 240° |
| 2 | 2384 | 0.19 | 192° | 50.7g | 287° | 28.3g | 257° | 12.2g | 240° |
| | | | | | | | | 16.7g | 270° |
| 3 | 2395 | 0.09 | 166° | 58.8g | 284° | 33.0g | 259° | 12.2g | 240° |
| | | | | | | | | 21.9g | 270° |
| 4 | 2395 | 0.03 | 141° | 0.0g | 0° | | | | |

Figure 6-18. Dynamic balancing results.

manufacturer. After removing the previous weight package, the actual corrective action taken by the technician was to split the weight with 12.2 grams added to the 240° location and 16.7 grams at the 270° hole. The balancer will undertake the calculations involved in determining a split weight solution. Note that the recommended location (257°) is between the two locations that actually received weight (240° and 270°). The outcome of the added weight produced a vibration of 0.09 IPS at 166°. The balancer prescribed the addition of 33.0 grams at 259°. The technician again split the weight with 12.2 grams at 240° and 21.9 grams at 270°. In this instance, the 12.2 grams at 240° was left unmolested and 5.2 grams were added at the 270° location to yield at total weight at that location of 21.9 grams. There will be instances where the quantity of weight recommended is too large for a single location necessitating the splitting of the weight package. The fourth test run generated a vibration of 0.03 IPS. No further action was implemented. Compared to the original vibration of 0.56 IPS, the resultant vibration of 0.03 IPS represents a significant reduction in vibration. Most manufacturers recommend a dynamic vibration level no greater than 0.2 IPS. Many mechanics strive to reduce vibrations as much as possible.

VIBRATION SPECTRUM SURVEY

Most dynamic vibration equipment includes a feature where a vibration spectrum survey may be taken. The dynamic balancing procedure minimizes the one per revolution vibration induced by an out of balance propeller. Next, the technician should investigate the overall integrity of the rotating components to determine what is generating the vibration. This may be accomplished by a Vibration Spectrum Survey and an analysis of the results.

This spectral survey will show all of the vibration levels and their frequencies (in rpm, cycles per minute (CPM), or hertz) within the rotating component. Every moving part in an engine produces a vibration level at the frequency at which the component moves, or if the part is non moving, it will vibrate by nature of its own natural frequency. Unfortunately, some of the components share similar or identical frequencies, which makes analyzing a bit more challenging. During the balancing procedure if two vibration sensors were installed on the engine, the balancer will use the inputs from the sensors to gather spectral data. (Figure 6-19)

Each engine and propeller combination, when healthy, will produce a normal spectrum display that is characteristic

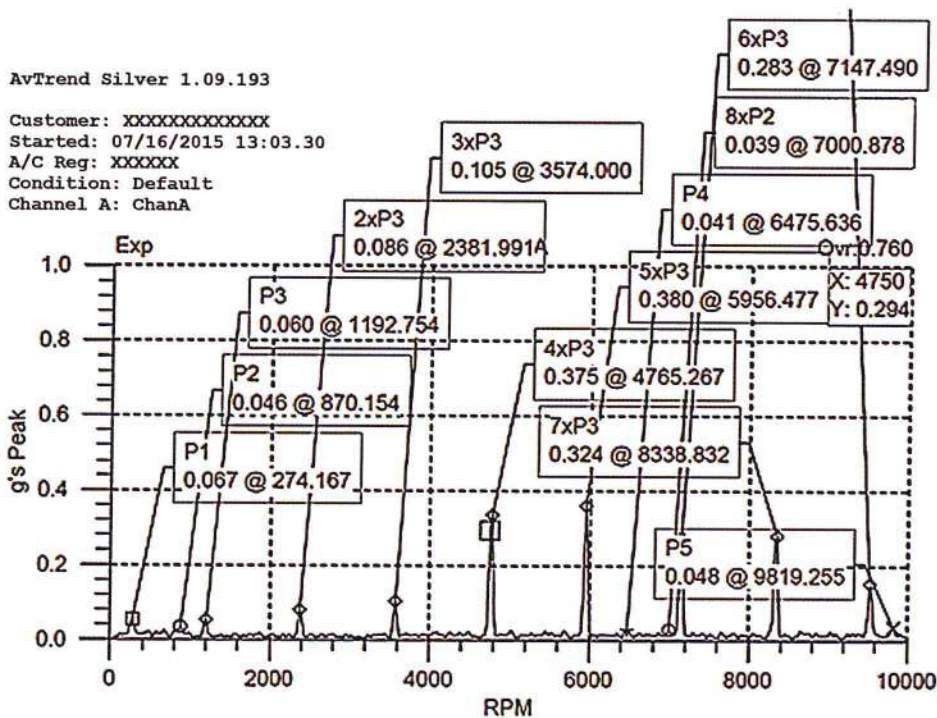

Figure 6-19. Sample vibration spectrum survey.

of that combination. The trick is to determine when this spectral display is not normal. When the spectral data is gathered, the analyzer will produce a digital display of the vibration readings, sometimes called a “signature,” which then has to be interpreted. Each one of the spikes or peaks shown in the graph is representative of a rotating component or a multiple thereof. These multiples of the fundamental rpm are referred to as “harmonics” or “orders.” To fully understand the data presented in the vibration spectrum survey requires considerable training and specific knowledge of the engine.

A dynamic balancing example is presented in this section. Always refer to the aircraft, propeller manuals, and other appropriate data when performing any balancing procedure. Dynamic balance is accomplished by using an accurate means of measuring the amount and location of the dynamic imbalance. The number of balance weights installed must not exceed the limits specified by the propeller manufacturer. Follow the dynamic balance equipment manufacturer’s instructions for dynamic balance in addition to the specifications of the propeller.

PROPELLER LUBRICATION

Hydromatic propellers operated with engine oil and some sealed propellers do not require lubrication. Electric propellers require oils and greases for hub

lubricants and pitch change drive mechanisms. Proper propeller lubrication procedures, with oil and grease specifications, are usually published in the manufacturer’s technical data. Experience indicates that water sometimes gets into the propeller blade bearing assembly on some models of propellers. For this reason, the propeller manufacturer’s greasing schedule must be followed to ensure proper lubrication of moving parts and protection from corrosion. Observe overhaul periods because most defects in propellers are not external, but unseen internal corrosion. Dissimilar metals in the prop and hub in combination with heating and cooling create an environment ripe for corrosion, and the only way to properly inspect many of these areas is through a teardown. Extensive corrosion can dramatically reduce the strength of the blades or hub. Even seemingly minor corrosion may cause a blade or hub to fail an inspection. Because of the safety implications (blade loss), this is clearly an area in which close monitoring is needed.

One example of the lubrication requirements and procedures is detailed here for illustration purposes only. Lubrication intervals are important to adhere to because of corrosion implications. The propeller must be lubricated at intervals not to exceed 100 hours or 12 calendar months, whichever occurs first. If annual operation is significantly less than 100 hours, calendar

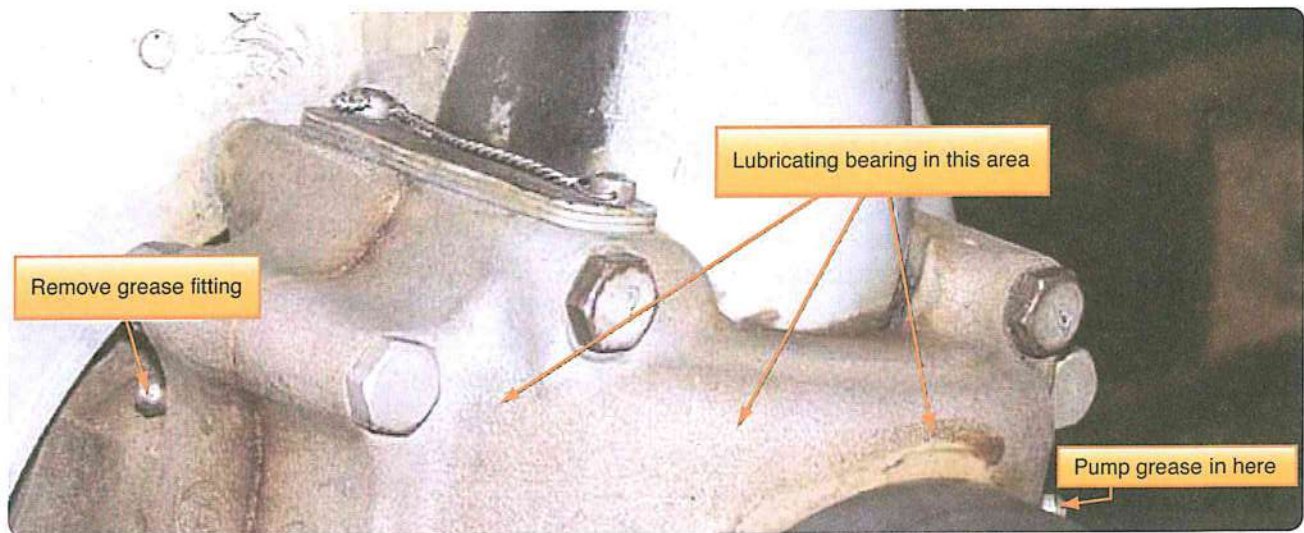

Figure 6-20. Sample lubrication points on propeller hub.

lubrication intervals should be reduced to six months. If the aircraft is operated or stored under adverse atmospheric conditions, such as high humidity, salt air, calendar lubrication intervals should be reduced to six months. Hartzell recommends that new or recently overhauled propellers be lubricated after the first one or two hours of operation because centrifugal loads pack and redistribute grease, which may result in a propeller imbalance. Redistribution of grease may also result in voids in the blade bearing area where moisture can collect. Remove the appropriate lubrication fitting for each blade from the propeller hub. (Figure 6-20) Pump one fluid ounce (30 milliliters (ml)) grease into the fitting located nearest the leading edge of the blade on a tractor installation, or nearest the trailing edge on a pusher installation, until grease emerges from the hole where the fitting was removed, whichever occurs first.

NOTE: one fluid ounce (30 ml) is approximately six pumps with a hand operated grease gun. Reinstall the removed lubrication fittings. Tighten the fittings until snug. Make sure that the ball of each lubrication fitting is properly seated. Reinstall a lubrication fitting cap on each lubrication fitting. Perform grease replacement through attached pressure fittings (zerks) in accordance with the manufacturer's instructions.

CHARGING THE PROPELLER AIR DOME

These instructions are general in nature and do not represent any particular aircraft procedure. Always check the correct manual before servicing any propeller system. Examine the propeller to make sure that it is positioned on the start locks and using the proper control, then charge the cylinder with dry air or nitrogen. The air charge valve is located on the cylinder



Figure 6-21. Gas charging port on propeller dome.

of the propeller dome as shown in *Figure 6-21*. Nitrogen is the preferred charging medium. The correct charge pressure is identified by checking the correct table shown. The temperature is used to find the correct pressure to charge the hub air pressure.

TACHOMETER CHECK

Tachometer inspection is a very important part of the overall propeller inspection. Operation with an inaccurate tachometer may result in restricted rpm operation and damaging high stresses. Over speeding propellers may cause considerable damage to the unit. This could shorten blade life and could result in catastrophic failure. If the tachometer is inaccurate, then the propeller could be turning faster than it is rated to turn, providing extra stress. In addition to the additional stress in the form of centrifugal force, the propeller may experience harmful vibrations. Accuracy of the engine tachometer should be verified at 100 hour intervals or at annual inspections, whichever occurs first. Tachometers should be accurate within ± 10 rpm. Handheld electronic tachometers, or electronic tachometers included with dynamic balancing equipment, may be used to evaluate the accuracy of the aircraft's tachometer(s). (*Figure 6-22*)



Figure 6-22. Electronic handheld tachometer checker. Note number of propeller blades shown in upper left of display window and rpm X 10 shown in display. In this example, a three bladed propeller was revolving at 2 400 rpm.

CLEANING PROPELLERS

The inspection process of an aircraft propeller begins with the initial visual inspections. Pilots and technicians should note any evidence of oil or grease leaks in addition to the general condition of the propeller. Because of centrifugal force, oil and grease leaks may sling away from the origin of the leak. On variable pitch propellers, common leaks take place at the blade root seals and where the propeller attaches to the flange of the crankshaft or propeller shaft. Cracks in the propeller hub may also develop leaks. Once the propeller is clean, an inspection to locate the source(s) of any leak(s) should be conducted.

Following the preliminary inspection the propeller should be cleaned in order to perform a more thorough inspection. Adhere to the cleaning instructions provided by the manufacturer. Generally, oil and grease accumulations are removed with solvent on a wiping rag and the blades are further cleaned with soap and water on a rag. Technicians need to be aware that aggressive scrubbing of the propeller with harsh brushes, steel wool, abrasive pads, scouring agents, and harsh chemicals may damage the protective finish applied to propellers. Do not use high pressure washers on variable pitch propellers as water, and soap, may enter the hub and generate corrosion.

Propellers operating in a salt water environment should have their propellers flushed with fresh water until the salt residue has been thoroughly removed. It may be necessary to coat metal parts of the propeller with a light film of oil to protect the propeller from the salt water environment. Refer to manufacturer's instruction regarding salt water operations.

PROPELLER REPAIRS

Generally, repairs to propellers that may be undertaken by technicians in the field are limited to minor repairs. Due to the high stresses placed on propellers during operation, the result of a failed propeller is often catastrophic. As a consequence, major repairs are limited to repair facilities that specialize in propeller repairs.

During operation, the propeller blades are subjected to erosion, small nicks, and other forms of minor damage. In general, erosion may be removed using abrasive paper. Normally a coarser abrasive paper is used to remove the erosion followed by smoother abrasives to remove the sanding marks. Nicks, and more severe damage, should

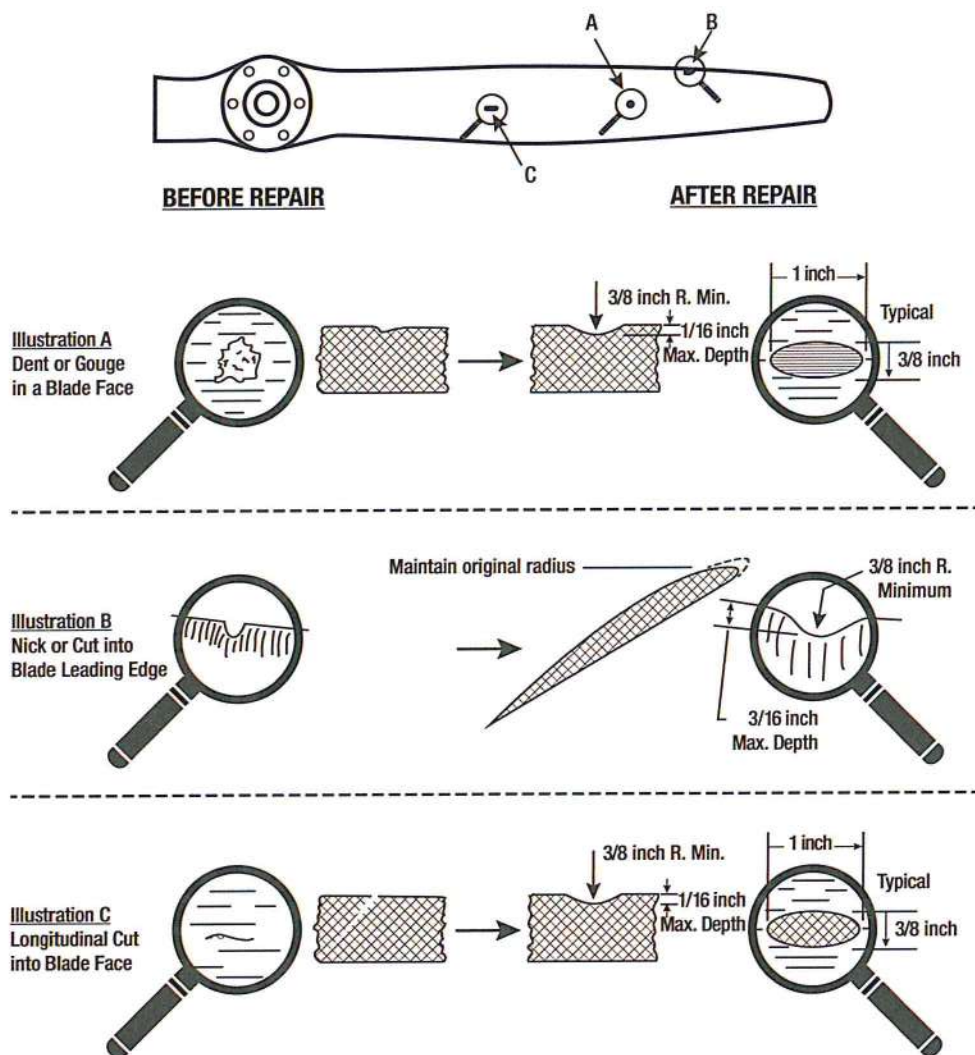

Figure 6-23. Examples of dressing defects from propeller blades.

be investigated using the manufacturer's technical data to determine serviceability. If the damage is repairable, the technician must follow the instructions from the manufacturer. A common practice is to remove the damage using files followed by the use of abrasive papers to remove the file marks. As with the removal of erosion, a coarse abrasive is first used followed by a fine abrasive. When completed, there should be no trace of file marks or marks left by coarse abrasives.

The manufacturer may provide a series of drawings revealing where repairs may be made and the extent of the repair and associated limitations. One manufacturer recommends that nicks and gouges need to be measured to determine the depth of the damage. After determining the depth, the area of dressing from the leading and trailing edges of the propeller is 10 times the depth. For the back and face of the propeller, the dressed out area is to be 20 times the depth of the damage. In each case, the

repair must be gently feathered to and from the original damage so that no sharp edges are present. A sample of typical repair procedures involving the dressing of aluminum propeller blades is presented in *Figure 6-23*.

At the conclusion of the dressing operation, the blade should be examined to ensure that all the damage has been removed. The first check is conducted using a 10 power magnifying glass. A dye penetrant inspection should also be used to further check for cracks at the bottom of the dressed out location. This measure adds to the certainty that the original damage has been removed.

After dressing the minor damage from the propeller blade, the repaired area must have its protective finish restored to prevent the formation of corrosion. Follow the instructions from the manufacturer to determine the chemical treatment(s) and finishes that need to be applied to the repair.

the engine. As with most aircraft components, all of the hardware on the propeller assembly must be safety wired, unless secured by self locking hardware or other devices. The final inspector examines the propeller and completes maintenance release tags reflecting the work accomplished. These documents certify that the major repairs and/or alterations that have been made meet established standards and that the propeller is approved for return to service. All minor repairs and minor alterations made on propellers must be accomplished by the propeller manufacturer, a certified repair station, an airframe and power plant technician, or a person working under the direct supervision of such a technician or an appropriately rated air carrier. Major repairs or alterations, including the overhaul of controllable pitch propellers, must be done by an appropriately rated repair station, manufacturer, or air carrier.

TROUBLESHOOTING PROPELLERS

Some common examples of troubleshooting problems and probable causes are provided in the following subsections. Always refer to the appropriate manual for actual information on troubleshooting.

HUNTING AND SURGING

Hunting is characterized by a cyclic variation in engine speed above and below the desired rpm. Surging is characterized by a large increase/decrease in engine speed, followed by a return to set speed after one or two occurrences. If a propeller is hunting, an appropriately licensed repair facility should check:

1. Governor,
2. Fuel control, and
3. Synchrophaser or synchronizer, if equipped.

ENGINE SPEED VARIES WITH FLIGHT ATTITUDE (AIRSPEED)

Small variances in engine speed are normal and are no cause for concern. An increase in engine speed while descending or increasing airspeed with a non-feathering propeller could be.

1. The governor not increasing oil volume in the propeller.
2. Engine transfer bearing leaking excessively.
3. Excessive friction in blade bearings or pitch changing mechanism.

FAILURE TO FEATHER OR FEATHERS SLOWLY

Failure to feather or slow feathering of the propeller requires the technician to:

1. Refer to the air charge section in the maintenance manual if the air charge is lost or low.
2. Check for proper function and rigging of propeller/governor control linkage.
3. Check the governor drain function.
4. Check the propeller for misadjustment or internal corrosion (usually in blade bearings or pitch change mechanism) that results in excessive friction. This must be performed at an appropriately licensed propeller repair facility.

PROPELLER GOVERNOR INSPECTION, MAINTENANCE, AND ADJUSTMENT

Once properly installed and adjusted, the propeller governor requires little in terms of maintenance and further adjustments. The operation of the governor is checked before each flight. In general, the governor will normally achieve its time-between-overhaul barring some defect.

The governor typically receives a visual inspection during the routine inspections. Technicians should check for oil leaks and rigging. Ensure that the control has full travel and makes positive contact with the adjustment screw when the propeller control is in its **High RPM** or **Low Pitch** position. Check the connection of the control at the governor lever for hardware safety and smooth movement. This check requires two people, one to move the control in the flight deck and another to observe the control movement at the governor. If equipped, check the connection of the accumulator and wires associated with the propeller synchronizing/synchrophasing systems. Evidence of oil at the mounting base of the governor reveals a leaky installation. Check the torque of the mounting fasteners and torque, as required. It may be necessary to replace the mounting gasket.

When replacing the propeller or propeller governor, an operational check of the system should be performed. After starting the engine and allowing the engine to reach normal cylinder head (CHT) and oil temperature readings, perform an engine run-up test. In particular, cycle the propeller, perform a feather/unfeather check, if applicable, and check the static rpm attained by the

engine at the full throttle position with the propeller control in the **High RPM** or **Low Pitch** position. Compare the static rpm results against the appropriate specifications to determine whether adjustments are necessary. Comparing the accuracy of the tachometer should also be conducted during the static rpm check. An electronic rpm checker (*Figure 6-3*) is simple to use and provides accurate rpm readings.

If the static rpm is too high, lower to maximum rpm by removing safety wire, if installed, loosening the jam nut, and turning the adjustment screw in the appropriate direction. For many governors, turning the adjuster in a clockwise direction will lower rpm. The rate of rpm reduction is approximately 25 rpm for each complete revolution of the adjuster. Tighten the jam nut and recheck the static rpm. When correctly set, resafety the rpm adjuster.

If the static rpm is too low, two mechanical issues must be considered. One is that the physical low-pitch stop of the propeller is limiting rpm and the other is that the propeller governor high-rpm adjuster requires adjustment. A simple test to perform is to run the engine at full throttle and move the propeller control in and out of the **High RPM** or **Low Pitch** stop. Only move the propeller control the requisite amount to change propeller pitch. If the maximum obtainable rpm is achieved before the propeller governor lever reaches its **High RPM** or **Low Pitch** stop, the propeller pitch is the limiting factor. If the maximum obtainable rpm is reached as the governor reaches its **High RPM** or **Low Pitch** stop, the governor should be readjusted. As previously indicated, one complete revolution of the adjuster screw yields a change of 25 rpm. Ensure that the rpm adjustment hardware is properly safetied and the conclusion of the adjustment. (*Figure 6-24*)

A couple of points to consider during the test. Do not exceed engine temperatures. As the governor tests and adjustment require a considerable number of high power operations, cylinder and oil temperatures require close observation and adherence. Also, climatic conditions may have a negative impact on the performance of the engine. High altitude, high temperature, and high humidity work to reduce engine output. Consequently, before increasing the rpm adjustment on the governor, it may be necessary to check the governor adjustment during flight when the static rpm test yields a low value. The maximum rpm developed by the engine should also be checked during flight. If necessary, re-adjust the system to provide the correct rpm during flight.

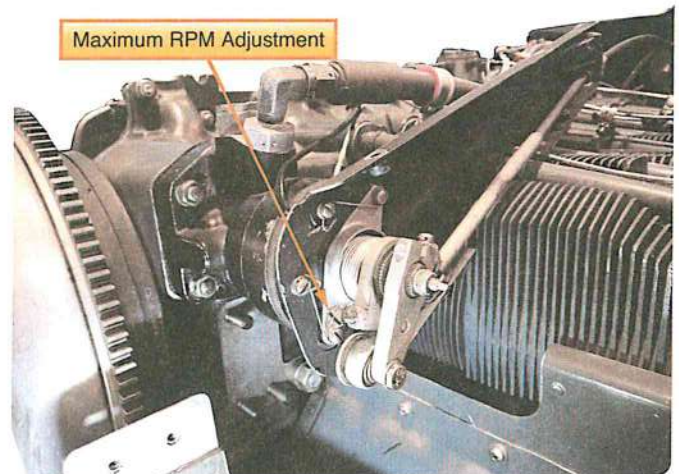

Figure 6-24. Propeller governor maximum rpm adjustment.

QUESTIONS

Question: 6-1

When inspecting a propeller by hand for the proper fit of a blade within its hub, how much play is allowed when pushing or pulling in or out of the hub?

Question: 6-5

What types of imbalance is correctable by employing the dynamic balancing technique?

Question: 6-2

On a composite propeller blade how are locations that are delaminated or have become debonded detected?

Question: 6-6

Name two acceptable methods for indicating or marking blade stations on a propeller blade.

Question: 6-3

Name seven inspection techniques which are suitable for inspecting aluminum propeller blades.

Question: 6-7

A dynamic balancer uses a photo-tachometer sensor system. What function(s) is/are served by this sensor system?

Question: 6-4

Name three factors that could cause a propeller to be "out of track".

Question: 6-8

What is the final determination of whether an out of balance propeller may be rebalanced and returned to service?

ANSWERS

Answer: 6-1

None! Although a slight amount of play is allowed when feeling for rotation of the blade within the hub.

Answer: 6-5

Mass imbalance.

Answer: 6-2

Hollow sound emanating from the coin tapping action.

Answer: 6-6

Masking tape and a non-permanent marker.

Answer: 6-3

Visual; tactile; dye penetrant; etching; chromic acid; eddy current; ultrasound.

Answer: 6-7

Measures rpm; establishes a position to pinpoint vibration and where to locate balancing weights.

Answer: 6-4

Bent blade; bent propeller hub; improperly tightened or torqued mounting hardware.

Answer: 6-8

The manufacturer's published limitations.



PROPELLER

PROPELLER STORAGE AND PRESERVATION

SUB-MODULE 07

PART-66 SYLLABUS LEVELS

CERTIFICATION CATEGORY →

| A | B1 |
|---|----|
| 1 | 2 |

Sub-Module 07

PROPELLER STORAGE AND PRESERVATION

Knowledge Requirements

17.7 – Propeller Storage and Preservation

Propeller preservation and depreservation.

Level 1

A familiarization with the principal elements of the subject.

Objectives:

- (a) The applicant should be familiar with the basic elements of the subject.
- (b) The applicant should be able to give a simple description of the whole subject, using common words and examples.
- (c) The applicant should be able to use typical terms.

Level 2

A general knowledge of the theoretical and practical aspects of the subject and an ability to apply that knowledge.

Objectives:

- (a) The applicant should be able to understand the theoretical fundamentals of the subject.
- (b) The applicant should be able to give a general description of the subject using, as appropriate, typical examples.
- (c) The applicant should be able to use mathematical formula in conjunction with physical laws describing the subject.
- (d) The applicant should be able to read and understand sketches, drawings and schematics describing the subject.
- (e) The applicant should be able to apply his knowledge in a practical manner using detailed procedures.

GENERAL

The procedures and recommendations contained in this section are for educational purposes and do not supersede instructions provided by the manufacturers. Always follow the pertinent technical data presented by the manufacturer(s).

As the propeller is one of the most highly stressed component of the airplane, aircraft owners, operators, and technicians need to take necessary measures to protect the propeller during periods of inactivity. Often mechanical devices will experience advanced levels of decay from protracted periods of inactivity, especially when exposed to harsh environmental conditions. Not complying with storage and preservation measures may prove harmful to the propeller and require costly repairs or overhauls to return the propeller to flyable status. In general, the storage status of an aircraft is listed in three categories, flyable, temporary, and indefinite.

In terms of the propeller, when the aircraft is in flyable storage, the owner/operator should fly the aircraft at least once a month for a minimum of 30 minutes. If the propeller requires periodic greasing, the propeller should be greased every six months. Where normally the propeller is greased once a year or every 100 hours of operation, the additional greasing helps to protect the propeller from corrosion. Technicians should also grease the propeller at least every six months when the aircraft is operated in unfavorable atmospheric conditions, such as salt air and water and agricultural spraying.

Temporary storage is generally defined as non use of the aircraft for 90 days. Where the majority of steps taken to protect an engine under temporary storage focuses on protecting the cylinders, the series of plugs used to seal the interior of the engine from the atmosphere benefits a constant speed propeller, propeller governor, and accumulator. In addition, when the propeller requires greasing, the operation should be implemented every six months.

Under indefinite storage, the regular engine oil is replaced with a preservative oil, such as MIL-C-6529 Type II or similar product. The aircraft is then flown for 30 minutes. The preservative oil circulates through the interior of the propeller governor, the accumulator (if equipped), and the hub of the variable pitch propeller

that uses engine oil during operation and protects the propeller mechanism. This is especially the case with the vintage Hamilton Standard propellers that are lubed entirely from the engine oil system and do not have grease fittings and other supplemental lubricants. Relieve the pressures acting on the accumulator during indefinite storage.

Some basic steps that should be undertaken to protect propellers during periods of inactivity are common sense measures. Foremost, keep the propeller clean. If the propeller is exposed to a harsh environment, cleaning operations should be accomplished with regularity. Follow manufacturer's recommendations concerning cleaning fluids and methods. Be mindful that birds often perch on propellers and deposit corrosive waste on the blades. On metal propeller blades, applying a thin protective film of MIL-C-16173 Type II will minimize the risk of surface corrosion. This measure is more important with propeller blades that have erosion because they lack a proper finishing coat. Do not apply the protective film material to rubber components, such as the de-icing overshoes or boots and blade root seals.

Wooden propellers are perhaps the most delicate in regard to withstanding harsh environments. A common practice is to keep wooden propellers in a horizontal position to keep the moisture in the blades balanced. If possible, wooden propellers of inactive aircraft should be removed from aircraft that experience large amounts of yearly snowfall. Leaving snow and ice on wooden propellers month after month is likely to injure the protective coating placed on the propeller. Also, wooden propellers of inactive aircraft exposed to extreme hot and arid conditions with harsh sunlight should be removed from the aircraft. If possible, wooden propellers should be removed from the aircraft and stored indoors in a climate controlled environment when they would otherwise be exposed to extreme weather conditions. The application of preservatives to the metal propeller adapter used to attach the wooden propeller to the propeller shaft should be conducted to block corrosion.

LONG TERM STORAGE AND PRESERVATION

Long term storage and preservation procedures contained herein are for educational purposes. Always refer to the specific manufacturer for applicable technical data regarding their product.

In general, placing a propeller under a long term storage program includes a select number of approaches. Each technique protects the propeller by eliminating or minimizing the direct contact made between the product and the atmosphere. Moisture and sunlight work to deteriorate mechanical devices, fabrics, plastics, and other goods. Consequently, shielding the component under long term storage from moisture and sunlight is crucial to preserving the product.

One technique for protecting a component is to apply or reapply a plating process. Another is to coat the product with a protective chemical. The coating serves as a barrier between the product and the atmosphere. A third approach is to wrap the product with a physical covering. The latter shields the product from sunlight, moisture, dirt, birds, and insects, among other deteriorating elements. The wrapping substance should be non-hygroscopic and varies in terms of material ranging from coated paper products and light plastics to sturdy vinyl. A durable storage bag also protects the product from damage while being transported by road, rail, ship, and air. **(Figure 7-1)** Specially made containers may also be used to protect components during transportation and storage. The original shipping container or similar unit may be used. More elaborate containers are designed and constructed so that the unit may be evacuated of air and filled with a charge of dry nitrogen. The use of desiccants in such containers is common to absorb moisture.



Figure 7-1. Protective transport and storage bag.

Long term storage and preservation applies to any propeller not in service. The propeller may be a new unit that has never flown, or a propeller that has been overhauled and awaiting installation, or a propeller that has been removed from an aircraft. Storing propellers in a clean, climate controlled environment is recommended. If possible, the propeller should be stored in its shipping, or similar, container. Some large propellers may be stored on special racks. Do not store propellers by resting them on their blade tips.

As the internal members of a controllable-pitch propeller are prone to dissimilar metal corrosion, the hub should be filled with preservative oil, MIL-C-6529 Type II. The preservative oil may be blended with engine oil (e.g., 75% engine oil and 25% preservative oil). This provides a protective coating to the internal workings of the propeller. The propeller hub is then sealed with an appropriate plug.

Metal propeller blades should be coated, as previously mentioned, with MIL-C-16173 Type II. A thin film is adequate. Do not coat rubber parts with the MIL-C-16173 compound. The blades are then wrapped in a non hygroscopic (does not absorb water) material that provides a physical barrier between the metal blades and the atmosphere.

STORAGE OF PROPELLER GOVERNORS AND ACCUMULATORS

As with propellers that were installed during indefinite storage, propeller governors and accumulators may remain on the engine. The preservative used to coat the internal portions of the engine is satisfactory for the propeller governor and accumulator.

If the propeller governor is to be removed from the engine and placed in storage or preserved after overhaul or repair, the following procedure will protect the governor during the storage interval. Similar steps may be taken to protect the accumulator removed from the airplane.

For piston engine systems, apply preservative MIL-C-6529C Type II in the oil passages of the governor and accumulator. MIL-C-6529C Type III is formulated to work with turbine oils. Rotate the governor shaft to circulate the oil throughout the unit. Secure a base cover on the gasket surface of the governor. **(Figure 7-2)** This cover will help retain preservation oil within the

governor, block the entry of moisture, and mechanically protect the mounting portion of the governor from physical damage. Ensure that the accumulator is not pressurized. Cap the fitting. Note: preservation oils are available in pre-mix ready to use from the bottle blends to concentrated products that require mixing with regular oil before application.

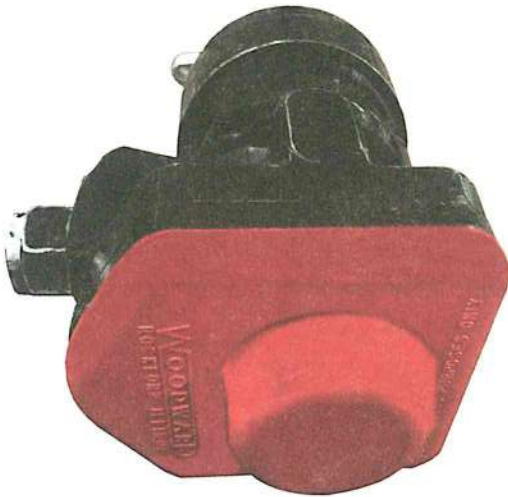

Figure 7-2. Protective cap placed on propeller governor mounting surface. Used for shipping and storage.

The preserved governor and accumulator should be stored in a shipping container or similar box. Inserting the governor and accumulator in separate vacuum storage bags, removing the air, and sealing the bags will further protect the governor and accumulator from the environment. The addition of desiccants within the storage containers is beneficial in terms of absorbing water vapor within the storage boxes. When able, the storage container should be kept in a dry indoor area with a controlled climate.

DURING PRESERVATION, DEPRESERVATION, AND RETURN TO SERVICE

The manufacturer may prescribe maintenance action to be undertaken after the propeller has been in storage for specific periods. For example, after three years of storage the propeller must be inspected externally for corrosion and other damage. The instructions may include replacing the preservative compounds on the blades and within the propeller hub.

Controllable-pitch propellers that are in storage for periods exceeding five years may require the replacement of rubber parts and an internal inspection for corrosion before returning the propeller to service.

If used, an inspection of the spinner bulkhead and spinner should be conducted prior to reinstalling the propeller. Correct defects or replace parts, as required. If equipped, inspect the components of the propeller anti-icing or de-icing system for defects. Repair or replace parts as necessary.

Before reinstalling a controllable-pitch propeller, drain the preservation fluid from the hub. Ensure that the O-ring, if used, is properly installed in the hub or on the propeller shaft. Align the propeller so that the blades will be at the specified clock angle. Likewise, if the propeller uses centering cones, follow manufacturer's instructions to make certain the cones are correctly installed and the contact area is correct.

On wooden propellers, clean off any preservation material applied to the metal propeller hub and associated hardware. Properly installed the propeller bolts and torque as directed. Often the torque is rechecked after 25 hours of operation. On aircraft that must be started by hand cranking, or propping, the position of the propeller blades is critical.

During the installation process, properly torque and safety propeller mounting hardware. On certain model propellers, it may be necessary to procure special wrenches/tools to properly torque the propeller mounting hardware.

After the propeller has been installed, remove any preservative film placed on the exterior of the propeller and propeller blades. Often a rag lightly moistened with a solvent may be used to wipe away the preservative compound. If necessary, grease the propeller and recharge the accumulator. Connect de-icing wires or anti-icing plumbing, if used. Align the index marks between the spinner and spinner bulkhead and fasten the spinner to the spinner bulkhead using the appropriate hardware.

Following the installation of the propeller, the engine should be started and tested. If the engine was placed under temporary or indefinite storage, a long list of

operations must be completed before the engine is ready to be tested. In regard to testing the propeller, the technician should perform a static rpm test to verify power output. If the propeller is controllable pitch, the propeller should be cycled several times to flush out air in the system and traces of preservation oil. A feathering propeller should have its system tested. Also, check the operation of the anti-icing/de-icing system, if equipped.

Following the testing of the propeller as per the manufacturer's instructions, perform a post run up inspection of the propeller and related components. Check for leaks and other abnormalities. When the propeller installation is ready for return to service, complete the necessary paperwork and associated forms.

QUESTIONS

Question: 7-1

When exposed to harsh environments, what happens to mechanical devices, such as a constant-speed propeller, that experience long periods of inactivity when not properly preserved?

Question: 7-5

Controllable-pitch propellers that are in storage for periods exceeding 5 years may require _____ prior to returning the propeller to service.

Question: 7-2

When an inactive aircraft is under a flyable storage program, how often should a constant speed propeller be greased, when applicable?

Question: 7-6

Name four factors that storage techniques are meant to protect against.

Question: 7-3

When an aircraft with a wooden propeller is stored for an extended period, the propeller blades should be left in _____ position.

Question: 7-4

A propeller has been removed from an aircraft and placed into storage. During storage, why is it recommended to wrap the unit with a non-hygroscopic material?

ANSWERS

Answer: 7-1

Metallic members may corrode; rubber seals may become brittle and develop leaks.

Answer: 7-5

An internal inspection for corrosion, and replacement of rubber parts.

Answer: 7-2

Every six months.

Answer: 7-6

Moisture; sunlight; dirt; physical damage.

Answer: 7-3

a horizontal

Answer: 7-4

Material serves as a physical barrier between the metal blades and the atmosphere; non-hygroscopic material does not absorb moisture.

| | | |
|-------|---|---|
| ANVS | / | Active Noise and Vibrations Suppression |
| AoA | / | Angle of Attack |
| ATF | / | Aerodynamic Twisting Force |
| ATM | / | Aerodynamic Twisting Moment |
| CHT | / | Cylinder Head Temperature |
| CPM | / | Cycles Per Minute |
| CRT/ | / | Cathode Ray Tube |
| CSU | / | Constant Speed Unit |
| CTF | / | Centrifugal Twisting Force |
| CTM | / | Centrifugal Twisting Moment |
| DC | / | Direct Current |
| FADEC | / | Full Authority Digital Engine Control |
| FCU | / | Fuel Control Unit |
| IPS | / | Inch Per Second |
| LPI | / | Liquid Penetrant Inspection |
| LSA | / | Light Sport Aircraft |
| MAP | / | Manifold Absolute Pressure |
| MEK | / | Methyl-Ethyl Keytone |
| ML | / | Milliliters |
| MPH | / | Miles Per Hour |
| MPI | / | Magnetic Particle Inspection |
| NDT | / | Nondestructive Testing |
| Nf | / | Engine Over Speed |
| PBA | / | Primary Blade Angle |
| PCU | / | Propeller Control Unit |
| PGB | / | Propeller Gear Box |
| PSI | / | Pounds Per Square Inch |
| PY | / | Pressurized Air Line |
| RAF | / | Relative Airflow |
| RPM | / | Rotations Per Minute |

Accumulator - A device containing two chambers, one for oil and the other for retaining a compressed gas, to aid in unfeathering a propeller.

Aerodynamic twisting moment (ATM) - An operational force acting on a propeller that works to increase the propeller blade pitch angle. Also known as aerodynamic twisting force (ATF).

Aeromatic® Propeller - A specially designed variable-pitch propeller that automatically changes propeller pitch during flight without a direct control input from the pilot.

Airscrew - see Propeller

Angle of attack - The angle formed between the chord line of a propeller blade section and the relative wind or relative air flow (RAF).

Anti-icing system - A system that prevents the build up of ice on propeller blades. Anti-icing systems commonly apply an anti-icing fluid to the shank of the propeller blades.

Asymmetrical thrust - The loading of a propeller disk that causes one region to generate more thrust than the other portion. The difference in thrust production between the descending and ascending blades of a propeller when not flying in a level attitude. With a nose-up attitude on a right-hand rotating propeller, the descending blade produces more thrust than the ascending blade. This action generates a yawing moment. Also known as P-Factor.

Automatic propeller - (see Aeromatic® Propeller)

Back - The curved surface of a propeller blade. The face of a propeller blade is comparable to the upper surface of a wing.

Blade - One airfoil of a propeller extending from the hub to the tip. The blades of a propeller produce thrust as they rotate.

Blade angle - The angle formed by the chord line of a propeller blade segment and the plane of rotation of the propeller.

Blade butt - On a variable-pitch propeller, the portion of the propeller blade inserted into the hub. In relation to the blade tip, the blade butt is on the opposite end of the blade in terms of span.

Blade element theory - A theory whereby the propeller blade is divided into small segments so that the performance of each segment may be critically analyzed. By combining the performance of each segment, designers are able to closely predict the output of the propeller.

Blade index number - The maximum blade angle on a Hamilton-Standard counterweight propeller.

Blade paddle - A special tool used to physically rotate the blades in the hub by hand.

Blade root - On a variable-pitch propeller, the portion of a blade that is adjoining the hub often used to anchor the blade in the hub.

Blade shank - The rounded portion of a propeller blade protruding from the hub to the airfoil section of the propeller blade.

Blade station - A distance from the center of the propeller hub along the span of the propeller blade.

Blade tip - The most outward portion of the propeller blade.

Boots - Attached to the inboard segment of a propeller blade, boots are used for propeller anti-ice and de-ice operations. Also known as "overshoes."

Boss - The center portion, or hub, of a fixed-pitch propeller.

Brush block - Used to transfer electrical power from a stationary component to a moving part, such as slip rings. Brush blocks are commonly used for propeller de-icing and for propeller pitch change on electric propellers.

GLOSSARY

Centrifugal force - The force acting on a propeller that tends to cast the blades out of the propeller hub. Centrifugal force is applied to rotating masses.

Centrifugal twisting moment (CTM) - The force acting on a propeller that works to decrease the propeller blade angle. Also known as centrifugal twisting force (CTF).

Chord line - An imaginary line that runs from the leading edge to the trailing edge of an airfoil.

Climb propeller - A fixed-pitch propeller typically used on small aircraft that provides enhanced performance during takeoff and climb operations. In comparison to a cruise propeller, the climb propeller will typically have a lower blade pitch and may have a shorter diameter.

Comparison unit - The mechanism used with a propeller synchronization or synchrophasing system that collects and compares signals of the master engine and the slave engine(s) and transmits a signal to adjust the slave engine(s) rpm or blade phase angle to match that of the master engine.

Cone - The component used with a splined-propeller shaft that centers the propeller on the crankshaft or propeller shaft. Propellers that are not critically concentric with the crankshaft or propeller shaft will generate considerable vibration.

Constant-speed system - A propeller system in which a governor is used to maintain a constant engine rpm by changing propeller blade angle according to conditions.

Contra-rotating propellers - Where two propellers on the same axis rotate in opposite directions.

Controllable-pitch propeller - A propeller whose pitch may be changed by the pilot during flight. Controllable-pitch propeller systems range from units that allow the pilot to change propeller pitch, after which the propeller acts like a fixed-pitch propeller to those that change pitch automatically to maintain a constant engine rpm.

Counter-rotating propellers - When the propellers of a twin-engine aircraft rotate in opposite directions.

Counterweights - Weights added to the blade retention clamps of a controllable-pitch propeller. During operation, the counterweights work to increase propeller pitch using centrifugal force.

Critical engine - On a twin-engine airplane, the engine whose failure would most adversely affect the performance or handling qualities of an aircraft.

Critical rpm range - The rpm range at which dangerous harmonic vibrations between the engine and propeller are present. A red arc on the tachometer delineates this rpm range.

Cruise propeller - A fixed-pitch propeller typically used on small aircraft that provides efficiency during cruise operations. In comparison to a climb propeller, the cruise propeller will typically have a higher blade pitch and may have a longer diameter.

De-icing system - An ice removal system that allows ice to form on the propeller blades and subsequently remove the ice using heating elements and centrifugal force.

Delamination - When an individual laminate or multiple laminates of a wooden or composite propeller become de-bonded or separated from its adjacent member or laminate.

Dome assembly - The forward portion of a propeller that typically houses the pitch-changing mechanism of the propeller.

Dynamic propeller balancing - A procedure involving the use of electronic devices used to measure the magnitude and location of vibrations generated by the engine and propeller during operation. Through the use of dynamic balancers, vibrations may be detected and reduced normally by adding the specified weights to the indicated location(s).

Effective pitch - The actual distance forward that an aircraft travels with one revolution of the propeller.

Electric Propeller - A control system for propellers that allows the operator to vary blade pitch using an electric

motor, gear train, and brake mechanism rather than by hydraulic action. Electric propellers may or may not include a constant-speed provision and may have a simple procedure for feathering.

Erosion Strip - A protective material applied to, or used for, the leading edge of a propeller to minimize damage associated with leading edge erosion and nicks.

Face - The relatively flat side, or thrust side, of a propeller blade. The face of the propeller blade is comparable to the underside of a wing.

Feather - When the blades of a controllable-pitch propeller are rotated to a pitch angle of approximately 90°. This keeps the propeller of an inoperative engine from wind-milling and reduces drag during flight.

Fixed-pitch propeller - A propeller, commonly found on small aircraft, in which the angle of the propeller blades cannot be changed.

Flyweight assembly - A mechanism within the propeller governor that measures rpm. Using centrifugal force, the flyweight assembly exerts its might against the speeder spring and, in combination with the speeder spring, positions the pilot valve within the governor. The position of the pilot valve determines whether the propeller blades will increase pitch, maintain pitch, or decrease pitch.

Flanged propeller shaft - A propeller shaft whose mounting surface is a flange situated 90° to the centerline of the shaft.

Frequency generator - A device used to measure the rpm of the engine and provide data to the propeller synchronization system, when applicable.

Full Authority Digital Engine Control (FADEC) - Full-authority digital electronic control. A digital electronic fuel control for a gas turbine engine that is functioning during all engine operations, hence full authority. It includes the electronic engine control and functions with the flight management computer. FADEC schedules the fuel to the nozzles in such a way that prevents overshooting power changes and over-temperature

conditions. FADEC furnishes information to the EICAS (engine indication and crew alerting system). Modern turboprop engines typically use dual Full Authority Digital Engine Control (FADEC) to control both engine and propeller.

Geometric pitch - The theoretical distance that an aircraft would travel for each revolution of the propeller if slip was zero.

Go-no-go gauge - A special measuring tool used to determine whether parts have worn beyond their tolerances.

Governor - A device used to change blade pitch of a controllable-pitch propeller to automatically maintain constant rpm as the aircraft experiences changes in flight attitudes and other load factors.

Ground-adjustable propeller - A propeller that can have the blade angles changed while the aircraft is on the ground. These propellers do not have the ability to change blade pitch during flight.

Hub - The main structural component of a propeller that mounts to the crankshaft or propeller shaft and has the propeller blades attached.

Hydromatic® - A commonly used name for vintage Hamilton-Standard hydraulically operated propellers.

Leading edge - The forward edge of an airfoil.

Master engine - In regard to propeller synchronization systems, the master engine is set by the pilot and the slave engine(s) are altered to match the operation of the master engine. Nodal Point - The bending-point where the flexing of propeller blades occur as a result of resonance.

Overshoe - See Boots.

P-Factor - See Asymmetrical thrust.

Pitch - Known as geometric pitch. Refers to blade angle.

GLOSSARY

Pitch distribution - The twist or change in a propeller blade pitch angle along its span.

Plane of rotation - The plane in which the propeller rotates during operation. This plane is 90° to the centerline of the crankshaft or propeller shaft.

Propeller - A device driven by an engine that has blades and when rotated produces thrust by the interaction with the air. In general terms, a propeller converts the output of a piston or turboprop engine into thrust.

Propeller disc - The circular area in which the propeller rotates.

Propeller track - The location where each tip of the propeller blades travel during rotation. Checking propeller track is a common maintenance procedure.

Pulse generator - A device that detects blade position and rpm in a synchrophasing system.

Pusher propeller - A propeller installed on an aircraft engine or propeller shaft that faces aft. The thrust generated by the propeller pushes the aircraft forward.

Radial clearance - The distance from the tip of the propeller to the structure, fuselage, or other article in close proximity to the propeller disc.

Resonance - A force generated by the propeller due to vibrations that results in the flexing of the blades along their nodal point(s).

Reversing - Placing the propeller blades in a negative pitch angle to produce a braking action by the generation of reverse thrust. In terms of taxiing, reversed propellers may also be used to back up an aircraft.

Safetying - The application of a safety device or technique, such as self-locking hardware, safety wire, cotter pin, bend tab, safety peening, etc.

Slave engine - In regard to propeller synchronization systems, the slave engine(s) is(are) connected to the master engine. Slave engines adjust flight parameters to match those established by the mater engine.

Slinger ring - In regard to propeller anti-icing systems, slinger rings are attached to the propeller, crankshaft, or propeller shaft and receive the anti-icing fluid from the aircraft. Using centrifugal force, the fluid is transmitted from the slinger rings to the exit of the anti-icing fluid nozzles on the shank of the propeller blades to the distribution boots.

Slip - The difference between geometric pitch and effective pitch.

Slipstream effect - A yawing moment developed by the whirling air mass from the propeller as it interacts with the vertical fin and rudder of the airplane.

Snap ring - A member of a splined or tapered shaft installation used to aid in removal of the propeller assembly.

Speeder spring - A spring within the propeller governor used to establish and maintain rpm. The speeder spring, whose tension is adjustable by the operator, is placed in opposition to a flyweight assembly. When the speeder spring tension and flyweight action is equal, the engine is in an on-speed condition. When speeder spring tension over powers flyweight action, the engine is in an under-speed condition. And when the speeder spring tension is less than flyweight action, the engine is in an over-speed condition.

Spider - The structural member of various controllable-pitch propellers that attaches to the crankshaft or propeller shaft and has appendages on which the propeller blades are mounted.

Spinner - A special fairing installed on propellers to provide a streamline function and enhance the flow of air into the engine compartment.

Spinner bulkhead or backplate - The portion of the spinner that affixes to the propeller hub or engine shaft that provides the point of attachment for the spinner.

Splined shaft - A shaft manufactured with parallel slots running in a longitudinal direction upon which the hub of the propeller is mounted. The splines on the engine shaft interlock with those on the propeller hub and transmit the power generated by the engine to the propeller.

Static rpm - The maximum rpm that can be obtained at full throttle on the ground with the aircraft remaining stationary. Technicians compare the static rpm generated by the engine to applicable specifications to determine whether the engine is meeting its published power output.

Synchronization system - An apparatus that automatically keeps all engines operating at the same rpm.

Synchrophasing system - A sophisticated synchronization system that provides a means whereby the pilot is able to alter the relative position of the propeller blades during flight to reduce vibration and noise.

Synchroscope - An indicator used to synchronize engine rpm of multi-engine aircraft.

Tachometer-generator - An rpm sensing device that produces an electrical signal used to indicate rpm. Tachometer-generator signals may also be used by some synchronization systems to maintain equal rpm.

Tapered shaft - A crankshaft design whose propeller-mounting has a large diameter near the crankcase and tapers to a smaller diameter at the threaded end. The taper design is used to center the propeller hub with the axis of rotation of the shaft.

Test club - A specially-designed propeller used when operating an aircraft engine in a test cell. They are commonly used for breaking in a reciprocating power plant. Test club propellers have stubby blades with wide chords and provide a specific load and maximum cooling airflow to the engine. Test club propellers are not used for flight.

Thrust bending force - As a result of the thrust production, the thrust load bends the propeller blades forward. The amount of thrust bending is greater at the tip of the propeller due to the thinness of the propeller at that station.

Torque bending force - Torque bending force, in the form of air resistance, works to bend the propeller blades in the direction opposite that of rotation.

Tractor propeller - A propeller installed on an aircraft engine or propeller shaft that faces forward. The thrust generated by the propeller pulls the aircraft forward.

Two-position propeller - A controllable-pitch propeller design limited to two blade angles during flight.

A

Active Noise and Vibration Suppression System 4.6
 Anti-icing Systems 5.2
 Autofeathering System 3.11

B

Balancing Procedure 6.11
 Basic Propeller Principles 1.3
 Blade Assessment 6.3
 Blade Stations 2.6
 Blade Tracking 6.6
 Brush Block Assembly 5.7

C

Charging the Propeller Air Dome 6.16
 Checking and Adjusting Propeller Blade Angles 6.7
 Cleaning Propellers 6.17
 Coin Tap 6.6
 Components 3.12
 Composite Propeller Inspection 6.6
 Composite Propellers 2.6
 Constant-Speed Feathering Propellers 3.8
 Constant-Speed Propeller Operations 3.7
 Constant-Speed Propellers 2.8
 Contra-Rotating Propellers 2.10
 Controllable-Pitch Propeller 2.8
 Counter-Rotating Propellers 2.11

D

De-icing Systems 5.4
 During Preservation, Depreservation, and
 Return To Service 7.4
 Dye Penetrants, Etching, and Chromic Acid 6.4
 Dynamic Balancing 6.10

E

Eddy Current 6.5
 Electrically Controlled Propellers 3.25
 Engine Speed Varies With Flight Attitude
 (Airspeed) 6.20

F

FADEC Systems 4.3
 Failure to Feather or Feathers Slowly 6.20
 Feathering Operation 3.15
 Feathering Propellers 2.9
 Fixed-Pitch Propeller 2.7
 Fixed-Pitch Wooden Propellers 2.2
 Forces Acting on a Propeller 1.9
 Fundamentals 1.3

G

General 7.2
 Governor Mechanism 3.4
 Ground-Adjustable Propeller 2.8
 Gyroscopic Precession 1.11

H

Hamilton Standard Hydromatic Propellers 3.11
 Hamilton Standard Propeller Control 3.13
 Hartzell Constant-Speed, Non-feathering Propellers ... 3.7
 Hunting and Surging 6.20
 Hydromatic On Speed Condition 3.14
 Hydromatic Under Speed Condition 3.14

I

Inspection, Maintenance, and Testing
 Anti-Icing System 5.5
 Inspection, Maintenance, and Testing the
 Electric De-icing System 5.7
 Installation 2.12
 Introduction 1.2

L

Long Term Storage and Preservation 7.2

M

Magnetic Particles 6.5
 Metal Fixed-Pitch Propellers 2.5
 Metal Propeller Inspection 6.4

INDEX

O

| | |
|----------------------------|------|
| On Speed Condition..... | 3.6 |
| Operation..... | 4.5 |
| Over Speed Condition..... | 3.7 |
| Over Speed Protection..... | 3.24 |
| Overview..... | 1.2 |

P

| | |
|--|------|
| P-Factor..... | 1.10 |
| Pratt and Whitney PT-6 Hartzell Propeller System..... | 3.21 |
| Principles of Operation..... | 3.13 |
| Propeller Aerodynamic Process..... | 1.4 |
| Propeller Balancing..... | 6.9 |
| Propeller Construction..... | 2.2 |
| Propeller Governor..... | 3.4 |
| Propeller Governor Inspection, Maintenance, and Adjustment..... | 6.20 |
| Propeller Hub, Shank, Back, and Face..... | 2.6 |
| Propeller Ice Protection Systems..... | 5.2 |
| Propeller Inspection and Maintenance..... | 6.2 |
| Propeller Location..... | 2.10 |
| Propeller Lubrication..... | 6.15 |
| Propeller Overhaul..... | 6.19 |
| Propeller Pitch Controls..... | 3.2 |
| Propeller Removal and Installation..... | 2.11 |
| Propeller Repairs..... | 6.17 |
| Propellers Used on General Aviation Aircraft..... | 2.2 |
| Propeller Synchronization..... | 4.2 |
| Propeller Synchronization Systems..... | 4.2 |
| Propeller Synchronizing..... | 4.3 |
| Propeller Vibration..... | 6.8 |
| Prop Reassembly..... | 6.19 |
| Pusher Propellers..... | 2.10 |

R

| | |
|-------------------------------|------|
| Range of Propeller Pitch..... | 1.8 |
| Reduction Gear Assembly..... | 3.19 |
| Removal..... | 2.11 |
| Replacing Overshoes..... | 5.8 |
| Resistance Checks..... | 5.8 |
| Reverse-Pitch Propellers..... | 2.10 |

S

| | |
|---|------|
| SAAB Synchronizer/Synchrophaser on Turboprop System..... | 4.5 |
| Sequencing Timer Assembly..... | 5.8 |
| Slipstream Effect..... | 1.11 |
| Static Balancing..... | 6.9 |
| Steel Propeller Blades..... | 2.5 |
| Storage of Propeller Governors and Accumulators..... | 7.3 |
| System Testing..... | 4.5 |

T

| | |
|---|------|
| Tachometer Check..... | 6.17 |
| Tactile Inspection..... | 6.2 |
| Test Club Propeller..... | 2.7 |
| The Hub..... | 6.19 |
| Torque..... | 1.11 |
| Torquing Wooden Propellers..... | 2.4 |
| Tractor Propeller..... | 2.10 |
| Troubleshooting Propellers..... | 6.20 |
| Turbo-Propeller Assembly..... | 3.19 |
| Turboprop Engines and Propeller Control Systems..... | 3.18 |
| Twin Engine Synchronizer/Synchrophaser Testing on Piston-Powered Aircraft..... | 4.4 |
| Types of Propellers..... | 2.7 |

U

| | |
|-------------------------------------|------|
| Ultra Sound..... | 6.5 |
| Under Speed Condition..... | 3.7 |
| Unfeathering..... | 3.10 |
| Unfeathering Operation..... | 3.17 |
| Universal Propeller Protractor..... | 6.7 |

V

| | |
|--------------------------------|------|
| Vibration and Resonance..... | 1.12 |
| Vibration Spectrum Survey..... | 6.14 |
| Visual Inspection..... | 6.2 |

W

| | |
|--------------------------------|-----|
| Wood Propeller Inspection..... | 6.4 |
|--------------------------------|-----|



AIRCRAFT
TECHNICAL
Book Company

+1 970 726-5111

www.actechbooks.com

72413 US Hwy 40
Tabernash, CO 80478-0270
USA

ISBN 978-1-941144-36-7



9 781941 144367 >